

# Intel® 64 and IA-32 Architectures Software Developer's Manual

## Volume 3B: System Programming Guide, Part 2

**NOTE:** The *Intel® 64 and IA-32 Architectures Software Developer's Manual* consists of seven volumes: *Basic Architecture*, Order Number 253665; *Instruction Set Reference A-L*, Order Number 253666; *Instruction Set Reference M-Z*, Order Number 253667; *Instruction Set Reference*, Order Number 326018; *System Programming Guide, Part 1*, Order Number 253668; *System Programming Guide, Part 2*, Order Number 253669; *System Programming Guide, Part 3*, Order Number 326019. Refer to all seven volumes when evaluating your design needs.

Order Number: 253669-042US  
March 2012

INFORMATION IN THIS DOCUMENT IS PROVIDED IN CONNECTION WITH INTEL PRODUCTS. NO LICENSE, EXPRESS OR IMPLIED, BY ESTOPPEL OR OTHERWISE, TO ANY INTELLECTUAL PROPERTY RIGHTS IS GRANTED BY THIS DOCUMENT. EXCEPT AS PROVIDED IN INTEL'S TERMS AND CONDITIONS OF SALE FOR SUCH PRODUCTS, INTEL ASSUMES NO LIABILITY WHATSOEVER AND INTEL DISCLAIMS ANY EXPRESS OR IMPLIED WARRANTY, RELATING TO SALE AND/OR USE OF INTEL PRODUCTS INCLUDING LIABILITY OR WARRANTIES RELATING TO FITNESS FOR A PARTICULAR PURPOSE, MERCHANTABILITY, OR INFRINGEMENT OF ANY PATENT, COPYRIGHT OR OTHER INTELLECTUAL PROPERTY RIGHT.

A "Mission Critical Application" is any application in which failure of the Intel Product could result, directly or indirectly, in personal injury or death. SHOULD YOU PURCHASE OR USE INTEL'S PRODUCTS FOR ANY SUCH MISSION CRITICAL APPLICATION, YOU SHALL INDEMNIFY AND HOLD INTEL AND ITS SUBSIDIARIES, SUB-CONTRACTORS AND AFFILIATES, AND THE DIRECTORS, OFFICERS, AND EMPLOYEES OF EACH, HARMLESS AGAINST ALL CLAIMS COSTS, DAMAGES, AND EXPENSES AND REASONABLE ATTORNEYS' FEES ARISING OUT OF, DIRECTLY OR INDIRECTLY, ANY CLAIM OF PRODUCT LIABILITY, PERSONAL INJURY, OR DEATH ARISING IN ANY WAY OUT OF SUCH MISSION CRITICAL APPLICATION, WHETHER OR NOT INTEL OR ITS SUB-CONTRACTOR WAS NEGLIGENT IN THE DESIGN, MANUFACTURE, OR WARNING OF THE INTEL PRODUCT OR ANY OF ITS PARTS.

Intel may make changes to specifications and product descriptions at any time, without notice. Designers must not rely on the absence or characteristics of any features or instructions marked "reserved" or "undefined". Intel reserves these for future definition and shall have no responsibility whatsoever for conflicts or incompatibilities arising from future changes to them. The information here is subject to change without notice. Do not finalize a design with this information.

The products described in this document may contain design defects or errors known as errata which may cause the product to deviate from published specifications. Current characterized errata are available on request.

Intel® AES-NI requires a computer system with an AES-NI enabled processor, as well as non-Intel software to execute the instructions in the correct sequence. AES-NI is available on select Intel® processors. For availability, consult your reseller or system manufacturer. For more information, see <http://software.intel.com/en-us/articles/intel-advanced-encryption-standard-instructions-aes-ni/>.

Intel® Hyper-Threading Technology (Intel® HT Technology) is available on select Intel® Core™ processors. Requires an Intel® HT Technology-enabled system. Consult your PC manufacturer. Performance will vary depending on the specific hardware and software used. For more information including details on which processors support HT Technology, visit <http://www.intel.com/info/hyperthreading>.

Intel® Virtualization Technology requires a computer system with an enabled Intel® processor, BIOS, and virtual machine monitor (VMM). Functionality, performance or other benefits will vary depending on hardware and software configurations. Software applications may not be compatible with all operating systems. Consult your PC manufacturer. For more information, visit <http://www.intel.com/go/virtualization>.

Intel® 64 architecture Requires a system with a 64-bit enabled processor, chipset, BIOS and software. Performance will vary depending on the specific hardware and software you use. Consult your PC manufacturer for more information. For more information, visit <http://www.intel.com/info/em64t>.

Enabling Execute Disable Bit functionality requires a PC with a processor with Execute Disable Bit capability and a supporting operating system. Check with your PC manufacturer on whether your system delivers Execute Disable Bit functionality.

Intel, the Intel logo, Pentium, Xeon, Intel NetBurst, Intel Core, Intel Core Solo, Intel Core Duo, Intel Core 2 Duo, Intel Core 2 Extreme, Intel Pentium D, Itanium, Intel SpeedStep, MMX, Intel Atom, and VTune are trademarks of Intel Corporation in the U.S. and/or other countries.

\*Other names and brands may be claimed as the property of others.

Contact your local Intel sales office or your distributor to obtain the latest specifications and before placing your product order.

Copies of documents which have an order number and are referenced in this document, or other Intel literature, may be obtained by calling 1-800-548-4725, or go to: <http://www.intel.com/design/literature.htm>

Copyright © 1997-2012 Intel Corporation. All rights reserved.

# CHAPTER 14

## POWER AND THERMAL MANAGEMENT

---

This chapter describes facilities of Intel 64 and IA-32 architecture used for power management and thermal monitoring.

### 14.1 ENHANCED INTEL SPEEDSTEP® TECHNOLOGY

Enhanced Intel SpeedStep® Technology was introduced in the Pentium M processor; it is available in Pentium 4, Intel Xeon, Intel® Core™ Solo, Intel® Core™ Duo, Intel® Atom™ and Intel® Core™2 Duo processors. The technology manages processor power consumption using performance state transitions. These states are defined as discrete operating points associated with different frequencies.

Enhanced Intel SpeedStep Technology differs from previous generations of Intel SpeedStep Technology in two ways:

- Centralization of the control mechanism and software interface in the processor by using model-specific registers.
- Reduced hardware overhead; this permits more frequent performance state transitions.

Previous generations of the Intel SpeedStep Technology require processors to be a deep sleep state, holding off bus master transfers for the duration of a performance state transition. Performance state transitions under the Enhanced Intel SpeedStep Technology are discrete transitions to a new target frequency.

Support is indicated by CPUID, using ECX feature bit 07. Enhanced Intel SpeedStep Technology is enabled by setting IA32\_MISC\_ENABLE MSR, bit 16. On reset, bit 16 of IA32\_MISC\_ENABLE MSR is cleared.

#### 14.1.1 Software Interface For Initiating Performance State Transitions

State transitions are initiated by writing a 16-bit value to the IA32\_PERF\_CTL register, see Figure 14-2. If a transition is already in progress, transition to a new value will subsequently take effect.

Reads of IA32\_PERF\_CTL determine the last targeted operating point. The current operating point can be read from IA32\_PERF\_STATUS. IA32\_PERF\_STATUS is updated dynamically.

The 16-bit encoding that defines valid operating points is model-specific. Applications and performance tools are not expected to use either IA32\_PERF\_CTL or IA32\_PERF\_STATUS and should treat both as reserved. Performance monitoring

tools can access model-specific events and report the occurrences of state transitions.

## 14.2 P-STATE HARDWARE COORDINATION

The Advanced Configuration and Power Interface (ACPI) defines performance states (P-state) that are used facilitate system software’s ability to manage processor power consumption. Different P-state correspond to different performance levels that are applied while the processor is actively executing instructions. Enhanced Intel SpeedStep Technology supports P-state by providing software interfaces that control the operating frequency and voltage of a processor.

With multiple processor cores residing in the same physical package, hardware dependencies may exist for a subset of logical processors on a platform. These dependencies may impose requirements that impact coordination of P-state transitions. As a result, multi-core processors may require an OS to provide additional software support for coordinating P-state transitions for those subsets of logical processors.

A BIOS (following ACPI 3.0 specification) can choose to expose P-state as dependent and hardware-coordinated to OS power management (OSPM) policy. To support OSPMs, multi-core processors must have additional built-in support for P-state hardware coordination and feedback.

Intel 64 and IA-32 processors with dependent P-state amongst a subset of logical processors permit hardware coordination of P-state and provide a hardware-coordination feedback mechanism using IA32\_MPERF MSR and IA32\_APERF MSR. See Figure 14-1 for an overview of the two 64-bit MSRs and the bullets below for a detailed description:

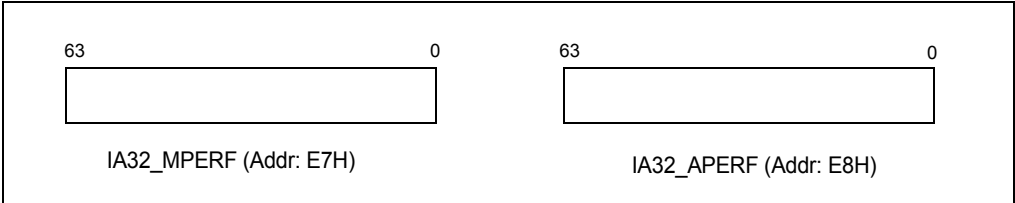


Figure 14-1. IA32\_MPERF MSR and IA32\_APERF MSR for P-state Coordination

- Use CPUID to check the P-State hardware coordination feedback capability bit. CPUID.06H.ECX[Bit 0] = 1 indicates IA32\_MPERF MSR and IA32\_APERF MSR are present.
- IA32\_MPERF MSR (0xE7) increments in proportion to a fixed frequency, which is configured when the processor is booted.

- IA32\_APERF MSR (0xE8) increments in proportion to actual performance, while accounting for hardware coordination of P-state and TM1/TM2; or software initiated throttling.
- The MSRs are per logical processor; they measure performance only when the targeted processor is in the C0 state.
- Only the IA32\_APERF/IA32\_MPERF ratio is architecturally defined; software should not attach meaning to the content of the individual of IA32\_APERF or IA32\_MPERF MSRs.
- When either MSR overflows, both MSRs are reset to zero and continue to increment.
- Both MSRs are full 64-bits counters. Each MSR can be written to independently. However, software should follow the guidelines illustrated in Example 14-1.

If P-states are exposed by the BIOS as hardware coordinated, software is expected to confirm processor support for P-state hardware coordination feedback and use the feedback mechanism to make P-state decisions. The OSPM is expected to either save away the current MSR values (for determination of the delta of the counter ratio at a later time) or reset both MSRs (execute WRMSR with 0 to these MSRs individually) at the start of the time window used for making the P-state decision. When not resetting the values, overflow of the MSRs can be detected by checking whether the new values read are less than the previously saved values.

Example 14-1 demonstrates steps for using the hardware feedback mechanism provided by IA32\_APERF MSR and IA32\_MPERF MSR to determine a target P-state.

#### Example 14-1. Determine Target P-state From Hardware Coordinated Feedback

```

DWORD PercentBusy; // Percentage of processor time not idle.
    // Measure "PercentBusy" during previous sampling window.
    // Typically, "PercentBusy" is measure over a time scale suitable for
    // power management decisions
    //
    // RDMSR of MCNT and ACNT should be performed without delay.
    // Software needs to exercise care to avoid delays between
    // the two RDMSRs (for example, interrupts).
MCNT = RDMSR(IA32_MPERF);
ACNT = RDMSR(IA32_APERF);

// PercentPerformance indicates the percentage of the processor
// that is in use. The calculation is based on the PercentBusy,
// that is the percentage of processor time not idle and the P-state
// hardware coordinated feedback using the ACNT/MCNT ratio.
// Note that both values need to be calculated over the same
// time window.
    PercentPerformance = PercentBusy * (ACNT/MCNT);

```

```
// This example does not cover the additional logic or algorithms  
// necessary to coordinate multiple logical processors to a target P-state.
```

```
TargetPstate = FindPstate(PercentPerformance);  
  
if (TargetPstate != currentPstate) {  
    SetPState(TargetPstate);  
}  
// WRMSR of MCNT and ACNT should be performed without delay.  
// Software needs to exercise care to avoid delays between  
// the two WRMSRs (for example, interrupts).  
WRMSR(IA32_MPERF, 0);  
WRMSR(IA32_APERF, 0);
```

### 14.3 SYSTEM SOFTWARE CONSIDERATIONS AND OPPORTUNISTIC PROCESSOR PERFORMANCE OPERATION

An Intel 64 processor may support a form of processor operation that takes advantage of design headroom to opportunistically increase performance. In Intel Core i7 processors, Intel Turbo Boost Technology can convert thermal headroom into higher performance across multi-threaded and single-threaded workloads. In Intel Core 2 processors, Intel Dynamic Acceleration can convert thermal headroom into higher performance if only one thread is active.

#### 14.3.1 Intel Dynamic Acceleration

Intel Core 2 Duo processor T 7700 introduces Intel Dynamic Acceleration (IDA). IDA takes advantage of thermal design headroom and opportunistically allows a single core to operate at a higher performance level when the operating system requests increased performance.

#### 14.3.2 System Software Interfaces for Opportunistic Processor Performance Operation

Opportunistic processor operation, applicable to Intel Dynamic Acceleration and Intel Turbo Boost Technology, has the following characteristics:

- A transition from a normal state of operation (e.g. IDA/Turbo mode disengaged) to a target state is not guaranteed, but may occur opportunistically after the

corresponding enable mechanism is activated, the headroom is available and certain criteria are met.

- The opportunistic processor performance operation is generally transparent to most application software.
- System software (BIOS and Operating system) must be aware of hardware support for opportunistic processor performance operation and may need to temporarily disengage opportunistic processor performance operation when it requires more predictable processor operation.
- When opportunistic processor performance operation is engaged, the OS should use hardware coordination feedback mechanisms to prevent un-intended policy effects if it is activated during inappropriate situations.

### 14.3.2.1 Discover Hardware Support and Enabling of Opportunistic Processor Operation

If an Intel 64 processor has hardware support for opportunistic processor performance operation, the power-on default state of IA32\_MISC\_ENABLE[38] indicates the presence of such hardware support. For Intel 64 processors that support opportunistic processor performance operation, the default value is 1, indicating its presence. For processors that do not support opportunistic processor performance operation, the default value is 0. The power-on default value of IA32\_MISC\_ENABLE[38] allows BIOS to detect the presence of hardware support of opportunistic processor performance operation.

IA32\_MISC\_ENABLE[38] is shared across all logical processors in a physical package. It is written by BIOS during platform initiation to enable/disable opportunistic processor operation in conjunction of OS power management capabilities, see Section 14.3.2.2. BIOS can set IA32\_MISC\_ENABLE[38] with 1 to disable opportunistic processor performance operation; it must clear the default value of IA32\_MISC\_ENABLE[38] to 0 to enable opportunistic processor performance operation. OS and applications must use CPUID leaf 06H if it needs to detect processors that has opportunistic processor operation enabled.

When CPUID is executed with EAX = 06H on input, Bit 1 of EAX in Leaf 06H (i.e. CPUID.06H:EAX[1]) indicates opportunistic processor performance operation, such as IDA, has been enabled by BIOS.

Opportunistic processor performance operation can be disabled by setting bit 38 of IA32\_MISC\_ENABLE. This mechanism is intended for BIOS only. If IA32\_MISC\_ENABLE[38] is set, CPUID.06H:EAX[1] will return 0.

### 14.3.2.2 OS Control of Opportunistic Processor Performance Operation

There may be phases of software execution in which system software cannot tolerate the non-deterministic aspects of opportunistic processor performance operation. For example, when calibrating a real-time workload to make a CPU reservation request

to the OS, it may be undesirable to allow the possibility of the processor delivering increased performance that cannot be sustained after the calibration phase.

System software can temporarily disengage opportunistic processor performance operation by setting bit 32 of the IA32\_PERF\_CTL MSR (0199H), using a read-modify-write sequence on the MSR. The opportunistic processor performance operation can be re-engaged by clearing bit 32 in IA32\_PERF\_CTL MSR, using a read-modify-write sequence. The DISENAGE bit in IA32\_PERF\_CTL is not reflected in bit 32 of the IA32\_PERF\_STATUS MSR (0198H), and it is not shared between logical processors in a physical package. In order for OS to engage IDA/Turbo mode, the BIOS must

- enable opportunistic processor performance operation, as described in Section 14.3.2.1,
- expose the operating points associated with IDA/Turbo mode to the OS.

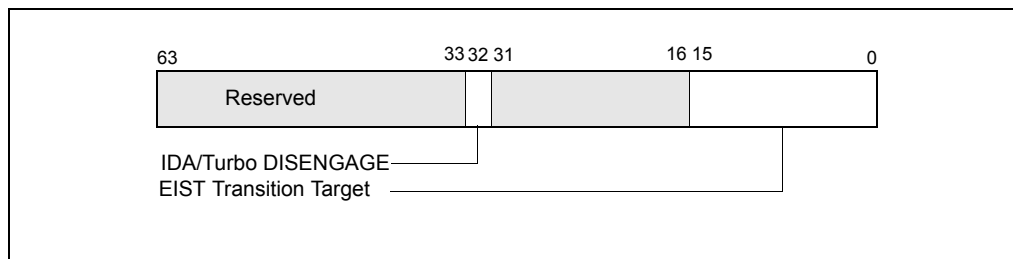


Figure 14-2. IA32\_PERF\_CTL Register

### 14.3.2.3 Required Changes to OS Power Management P-state Policy

Intel Dynamic Acceleration (IDA) and Intel Turbo Boost Technology can provide opportunistic performance greater than the performance level corresponding to the maximum qualified frequency of the processor (see CPUID's brand string information). System software can use a pair of MSRs to observe performance feedback. Software must query for the presence of IA32\_APERF and IA32\_MPERF (see Section 14.2). The ratio between IA32\_APERF and IA32\_MPERF is architecturally defined and a value greater than unity indicates performance increase occurred during the observation period due to IDA. Without incorporating such performance feedback, the target P-state evaluation algorithm can result in a non-optimal P-state target.

There are other scenarios under which OS power management may want to disable IDA, some of these are listed below:

- When engaging ACPI defined passive thermal management, it may be more effective to disable IDA for the duration of passive thermal management.
- When the user has indicated a policy preference of power savings over performance, OS power management may want to disable IDA while that policy is in effect.





- When the OS timer service transfers control, the application can use RDPMC (with ECX = 4000\_0001H) to read IA32\_PERF\_FIXED\_CTR1 (MSR address 30AH) to record the unhalted core clocktick (UCC) value; followed by RDPMC (ECX=4000\_0002H) to read IA32\_PERF\_FIXED\_CTR2 (MSR address 30BH) to record the unhalted reference clocktick (URC) value. This pair of values is needed for each logical processor for each sampling period.
- The application can calculate the Turbo activity ratio based on the difference of UCC between each sample period, over the difference of URC difference. The effective frequency of each sample period of the logical processor,  $i$ , can be estimated by:

$$(UCC_{n+1, i} - UCC_{n, i}) / (URC_{n+1, i} - URC_{n, i}) * \text{Base\_operating\_ratio} * 133.33\text{MHz}$$

It is possible that the OS had requested a lower-performance P-state during a sampling period. Thus the ratio  $(UCC_{n+1, i} - UCC_{n, i}) / (URC_{n+1, i} - URC_{n, i})$  can reflect the average of Turbo activity (driving the ratio above unity) and some lower P-state transitions (causing the ratio to be  $< 1$ ).

It is also possible that the OS might requested C-state transitions when the demand is low. The above ratio generally does not account for cycles any logical processor was idle. On Intel Core i7 processors, an application can make use of the time stamp counter (IA-32\_TSC) running at a constant frequency (i.e.  $\text{Base\_operating\_ratio} * 133.33\text{MHz}$ ) during C-states. Thus software can calculate ratios that can indicate fractions of sample period spent in the C0 state, using the unhalted reference clock-ticks and the invariant TSC. Note the estimate of fraction spent in C0 may be affected by SMM handler if the system software makes use of the "FREEZE\_WHILE\_SMM\_EN" capability to freeze performance counter values while the SMM handler is servicing an SMI (see Chapter 23, "Introduction to Virtual-Machine Extensions").

### 14.3.3 Intel Turbo Boost Technology

Intel Turbo Boost Technology is supported in Intel Core i7 processors and Intel Xeon processors based on Intel® microarchitecture code name Nehalem. It uses the same principle of leveraging thermal headroom to dynamically increase processor performance for single-threaded and multi-threaded/multi-tasking environment. The programming interface described in Section 14.3.2 also applies to Intel Turbo Boost Technology.

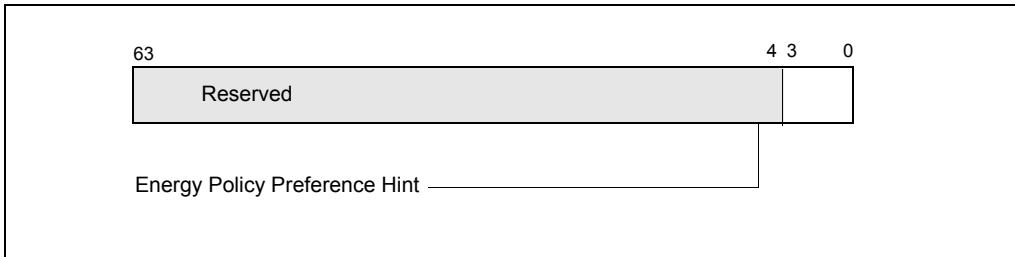
### 14.3.4 Performance and Energy Bias Hint support

Intel 64 processors may support additional software hint to guide the hardware heuristic of power management features to favor increasing dynamic performance or conserve energy consumption.

Software can detect processor's capability to support performance-energy bias preference hint by examining bit 3 of ECX in CPUID leaf 6. The processor supports this

capability if CPUID.06H:ECX.SETBH[bit 3] is set and it also implies the presence of a new architectural MSR called IA32\_ENERGY\_PERF\_BIAS (1B0H).

Software can program the lowest four bits of IA32\_ENERGY\_PERF\_BIAS MSR with a value from 0 - 15. The values represent a sliding scale, where a value of 0 (the default reset value) corresponds to a hint preference for highest performance and a value of 15 corresponds to the maximum energy savings. A value of 7 roughly translates into a hint to balance performance with energy consumption



**Figure 14-4. IA32\_ENERGY\_PERF\_BIAS Register**

The layout of IA32\_ENERGY\_PERF\_BIAS is shown in Figure 14-4. The scope of IA32\_ENERGY\_PERF\_BIAS is per logical processor, which means that each of the logical processors in the package can be programmed with a different value. This may be especially important in virtualization scenarios, where the performance / energy requirements of one logical processor may differ from the other. Conflicting "hints" from various logical processors at higher hierarchy level will be resolved in favor of performance over energy savings.

Software can use whatever criteria it sees fit to program the MSR with the appropriate value. However, the value only serves as a hint to the hardware and the actual impact on performance and energy savings is model specific.

## 14.4 MWAIT EXTENSIONS FOR ADVANCED POWER MANAGEMENT

IA-32 processors may support a number of C-states<sup>1</sup> that reduce power consumption for inactive states. Intel Core Solo and Intel Core Duo processors support both deeper C-state and MWAIT extensions that can be used by OS to implement power management policy.

1. The processor-specific C-states defined in MWAIT extensions can map to ACPI defined C-state types (C0, C1, C2, C3). The mapping relationship depends on the definition of a C-state by processor implementation and is exposed to OSPM by the BIOS using the ACPI defined \_CST table.

Software should use CPUID to discover if a target processor supports the enumeration of MWAIT extensions. If CPUID.05H.ECX[Bit 0] = 1, the target processor supports MWAIT extensions and their enumeration (see Chapter 3, "Instruction Set Reference, A-L," of *Intel® 64 and IA-32 Architectures Software Developer's Manual, Volume 2A*).

If CPUID.05H.ECX[Bit 1] = 1, the target processor supports using interrupts as break-events for MWAIT, even when interrupts are disabled. Use this feature to measure C-state residency as follows:

- Software can write to bit 0 in the MWAIT Extensions register (ECX) when issuing an MWAIT to enter into a processor-specific C-state or sub C-state.
- When a processor comes out of an inactive C-state or sub C-state, software can read a timestamp before an interrupt service routine (ISR) is potentially executed.

CPUID.05H.EDX allows software to enumerate processor-specific C-states and sub C-states available for use with MWAIT extensions. IA-32 processors may support more than one C-state of a given C-state type. These are called sub C-states. Numerically higher C-state have higher power savings and latency (upon entering and exiting) than lower-numbered C-state.

At CPL = 0, system software can specify desired C-state and sub C-state by using the MWAIT hints register (EAX). Processors will not go to C-state and sub C-state deeper than what is specified by the hint register. If CPL > 0 and if MONITOR/MWAIT is supported at CPL > 0, the processor will only enter C1-state (regardless of the C-state request in the hints register).

Executing MWAIT generates an exception on processors operating at a privilege level where MONITOR/MWAIT are not supported.

### NOTE

If MWAIT is used to enter a C-state (including sub C-state) that is numerically higher than C1, a store to the address range armed by MONITOR instruction will cause the processor to exit MWAIT if the store was originated by other processor agents. A store from non-processor agent may not cause the processor to exit MWAIT.

## 14.5 THERMAL MONITORING AND PROTECTION

The IA-32 architecture provides the following mechanisms for monitoring temperature and controlling thermal power:

1. The **catastrophic shutdown detector** forces processor execution to stop if the processor's core temperature rises above a preset limit.
2. **Automatic and adaptive thermal monitoring mechanisms** force the processor to reduce its power consumption in order to operate within predetermined temperature limits.

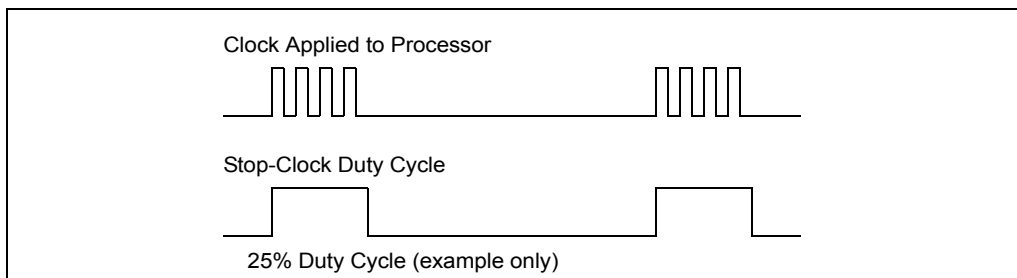
3. The **software controlled clock modulation mechanism** permits operating systems to implement power management policies that reduce power consumption; this is in addition to the reduction offered by automatic thermal monitoring mechanisms.
4. **On-die digital thermal sensor and interrupt mechanisms** permit the OS to manage thermal conditions natively without relying on BIOS or other system board components.

The first mechanism is not visible to software. The other three mechanisms are visible to software using processor feature information returned by executing CPUID with EAX = 1.

The second mechanism includes:

- **Automatic thermal monitoring** provides two modes of operation. One mode modulates the clock duty cycle; the second mode changes the processor's frequency. Both modes are used to control the core temperature of the processor.
- **Adaptive thermal monitoring** can provide flexible thermal management on processors made of multiple cores.

The third mechanism modulates the clock duty cycle of the processor. As shown in Figure 14-5, the phrase 'duty cycle' does not refer to the actual duty cycle of the clock signal. Instead it refers to the time period during which the clock signal is allowed to drive the processor chip. By using the stop clock mechanism to control how often the processor is clocked, processor power consumption can be modulated.



**Figure 14-5. Processor Modulation Through Stop-Clock Mechanism**

For previous automatic thermal monitoring mechanisms, software controlled mechanisms that changed processor operating parameters to impact changes in thermal conditions. Software did not have native access to the native thermal condition of the processor; nor could software alter the trigger condition that initiated software program control.

The fourth mechanism (listed above) provides access to an on-die digital thermal sensor using a model-specific register and uses an interrupt mechanism to alert software to initiate digital thermal monitoring.

## 14.5.1 Catastrophic Shutdown Detector

P6 family processors introduced a thermal sensor that acts as a catastrophic shutdown detector. This catastrophic shutdown detector was also implemented in Pentium 4, Intel Xeon and Pentium M processors. It is always enabled. When processor core temperature reaches a factory preset level, the sensor trips and processor execution is halted until after the next reset cycle.

## 14.5.2 Thermal Monitor

Pentium 4, Intel Xeon and Pentium M processors introduced a second temperature sensor that is factory-calibrated to trip when the processor's core temperature crosses a level corresponding to the recommended thermal design envelop. The trip-temperature of the second sensor is calibrated below the temperature assigned to the catastrophic shutdown detector.

### 14.5.2.1 Thermal Monitor 1

The Pentium 4 processor uses the second temperature sensor in conjunction with a mechanism called Thermal Monitor 1 (TM1) to control the core temperature of the processor. TM1 controls the processor's temperature by modulating the duty cycle of the processor clock. Modulation of duty cycles is processor model specific. Note that the processors STPCLK# pin is not used here; the stop-clock circuitry is controlled internally.

Support for TM1 is indicated by `CPUID.1:EDX.TM[bit 29] = 1`.

TM1 is enabled by setting the thermal-monitor enable flag (bit 3) in `IA32_MISC_ENABLE` [see Chapter 34, "Model-Specific Registers (MSRs)"]. Following a power-up or reset, the flag is cleared, disabling TM1. BIOS is required to enable only one automatic thermal monitoring modes. Operating systems and applications must not disable the operation of these mechanisms.

### 14.5.2.2 Thermal Monitor 2

An additional automatic thermal protection mechanism, called Thermal Monitor 2 (TM2), was introduced in the Intel Pentium M processor and also incorporated in newer models of the Pentium 4 processor family. Intel Core Duo and Solo processors, and Intel Core 2 Duo processor family all support TM1 and TM2. TM2 controls the core temperature of the processor by reducing the operating frequency and voltage of the processor and offers a higher performance level for a given level of power reduction than TM1.

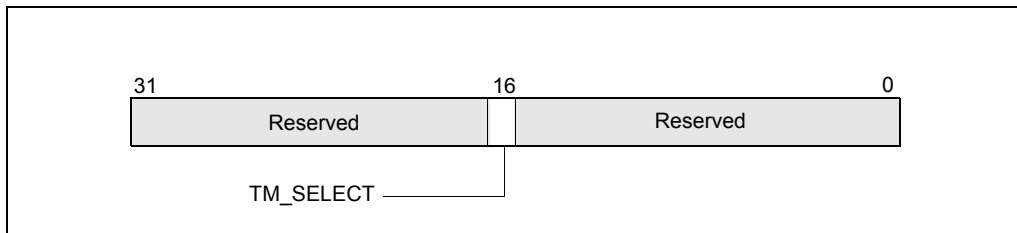
TM2 is triggered by the same temperature sensor as TM1. The mechanism to enable TM2 may be implemented differently across various IA-32 processor families with different CPUID signatures in the family encoding value, but will be uniform within an IA-32 processor family.

Support for TM2 is indicated by `CPUID.1:ECX.TM2[bit 8] = 1`.

### 14.5.2.3 Two Methods for Enabling TM2

On processors with CPUID family/model/stepping signature encoded as 0x69n or 0x6Dn (early Pentium M processors), TM2 is enabled if the `TM_SELECT` flag (bit 16) of the `MSR_THERM2_CTL` register is set to 1 (Figure 14-6) and bit 3 of the `IA32_MISC_ENABLE` register is set to 1.

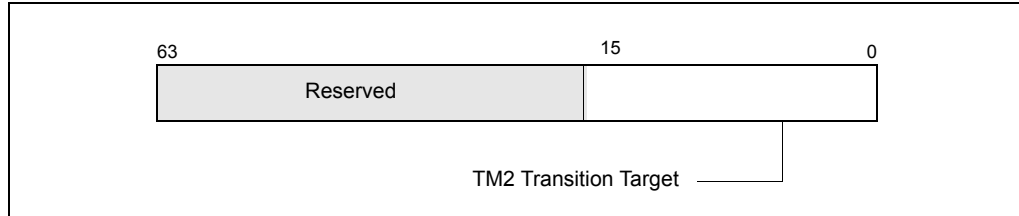
Following a power-up or reset, the `TM_SELECT` flag may be cleared. BIOS is required to enable either TM1 or TM2. Operating systems and applications must not disable mechanisms that enable TM1 or TM2. If bit 3 of the `IA32_MISC_ENABLE` register is set and `TM_SELECT` flag of the `MSR_THERM2_CTL` register is cleared, TM1 is enabled.



**Figure 14-6. MSR\_THERM2\_CTL Register On Processors with CPUID Family/Model/Stepping Signature Encoded as 0x69n or 0x6Dn**

On processors introduced after the Pentium 4 processor (this includes most Pentium M processors), the method used to enable TM2 is different. TM2 is enable by setting bit 13 of `IA32_MISC_ENABLE` register to 1. This applies to Intel Core Duo, Core Solo, and Intel Core 2 processor family.

The target operating frequency and voltage for the TM2 transition after TM2 is triggered is specified by the value written to `MSR_THERM2_CTL`, bits 15:0 (Figure 14-7). Following a power-up or reset, BIOS is required to enable at least one of these two thermal monitoring mechanisms. If both TM1 and TM2 are supported, BIOS may choose to enable TM2 instead of TM1. Operating systems and applications must not disable the mechanisms that enable TM1 or TM2; and they must not alter the value in bits 15:0 of the `MSR_THERM2_CTL` register.



**Figure 14-7. MSR\_THERM2\_CTL Register for Supporting TM2**

#### 14.5.2.4 Performance State Transitions and Thermal Monitoring

If the thermal control circuitry (TCC) for thermal monitor (TM1/TM2) is active, writes to the IA32\_PERF\_CTL will effect a new target operating point as follows:

- If TM1 is enabled and the TCC is engaged, the performance state transition can commence before the TCC is disengaged.
- If TM2 is enabled and the TCC is engaged, the performance state transition specified by a write to the IA32\_PERF\_CTL will commence after the TCC has disengaged.

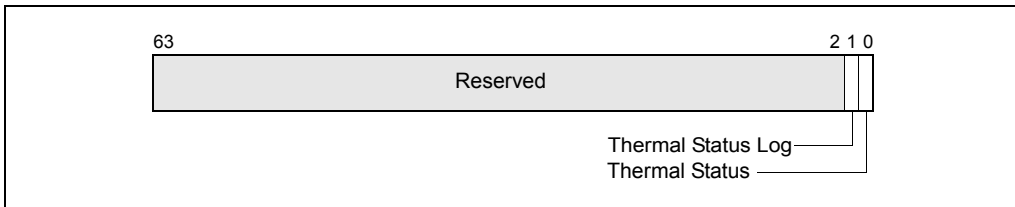
#### 14.5.2.5 Thermal Status Information

The status of the temperature sensor that triggers the thermal monitor (TM1/TM2) is indicated through the thermal status flag and thermal status log flag in the IA32\_THERM\_STATUS MSR (see Figure 14-8).

The functions of these flags are:

- **Thermal Status flag, bit 0** — When set, indicates that the processor core temperature is currently at the trip temperature of the thermal monitor and that the processor power consumption is being reduced via either TM1 or TM2, depending on which is enabled. When clear, the flag indicates that the core temperature is below the thermal monitor trip temperature. This flag is read only.
- **Thermal Status Log flag, bit 1** — When set, indicates that the thermal sensor has tripped since the last power-up or reset or since the last time that software cleared this flag. This flag is a sticky bit; once set it remains set until cleared by software or until a power-up or reset of the processor. The default state is clear.



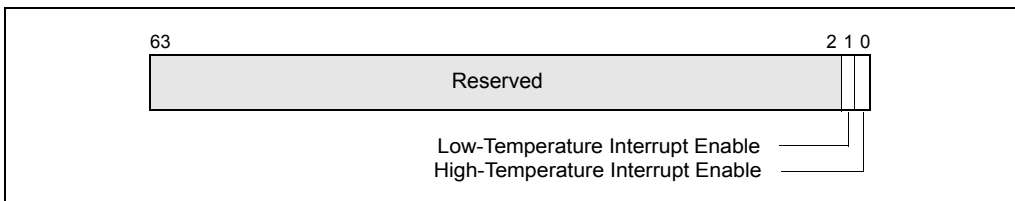


**Figure 14-8. IA32\_THERM\_STATUS MSR**

After the second temperature sensor has been tripped, the thermal monitor (TM1/TM2) will remain engaged for a minimum time period (on the order of 1 ms). The thermal monitor will remain engaged until the processor core temperature drops below the preset trip temperature of the temperature sensor, taking hysteresis into account.

While the processor is in a stop-clock state, interrupts will be blocked from interrupting the processor. This holding off of interrupts increases the interrupt latency, but does not cause interrupts to be lost. Outstanding interrupts remain pending until clock modulation is complete.

The thermal monitor can be programmed to generate an interrupt to the processor when the thermal sensor is tripped. The delivery mode, mask and vector for this interrupt can be programmed through the thermal entry in the local APIC's LVT (see Section 10.5.1, "Local Vector Table"). The low-temperature interrupt enable and high-temperature interrupt enable flags in the IA32\_THERM\_INTERRUPT MSR (see Figure 14-9) control when the interrupt is generated; that is, on a transition from a temperature below the trip point to above and/or vice-versa.



**Figure 14-9. IA32\_THERM\_INTERRUPT MSR**

- **High-Temperature Interrupt Enable flag, bit 0** — Enables an interrupt to be generated on the transition from a low-temperature to a high-temperature when set; disables the interrupt when clear.(R/W).
- **Low-Temperature Interrupt Enable flag, bit 1** — Enables an interrupt to be generated on the transition from a high-temperature to a low-temperature when set; disables the interrupt when clear.

The thermal monitor interrupt can be masked by the thermal LVT entry. After a power-up or reset, the low-temperature interrupt enable and high-temperature

interrupt enable flags in the IA32\_THERM\_INTERRUPT MSR are cleared (interrupts are disabled) and the thermal LVT entry is set to mask interrupts. This interrupt should be handled either by the operating system or system management mode (SMM) code.

Note that the operation of the thermal monitoring mechanism has no effect upon the clock rate of the processor's internal high-resolution timer (time stamp counter).

### 14.5.2.6 Adaptive Thermal Monitor

The Intel Core 2 Duo processor family supports enhanced thermal management mechanism, referred to as Adaptive Thermal Monitor (Adaptive TM).

Unlike TM2, Adaptive TM is not limited to one TM2 transition target. During a thermal trip event, Adaptive TM (if enabled) selects an optimal target operating point based on whether or not the current operating point has effectively cooled the processor.

Similar to TM2, Adaptive TM is enable by BIOS. The BIOS is required to test the TM1 and TM2 feature flags and enable all available thermal control mechanisms (including Adaptive TM) at platform initiation.

Adaptive TM is available only to a subset of processors that support TM2.

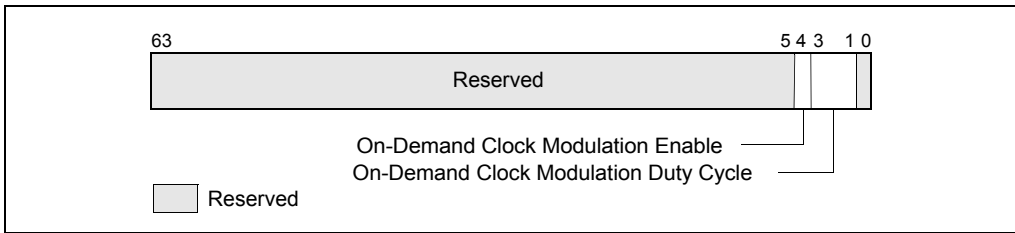
In each chip-multiprocessing (CMP) silicon die, each core has a unique thermal sensor that triggers independently. These thermal sensor can trigger TM1 or TM2 transitions in the same manner as described in Section 14.5.2.1 and Section 14.5.2.2. The trip point of the thermal sensor is not programmable by software since it is set during the fabrication of the processor.

Each thermal sensor in a processor core may be triggered independently to engage thermal management features. In Adaptive TM, both cores will transition to a lower frequency and/or lower voltage level if one sensor is triggered.

Triggering of this sensor is visible to software via the thermal interrupt LVT entry in the local APIC of a given core.

### 14.5.3 Software Controlled Clock Modulation

Pentium 4, Intel Xeon and Pentium M processors also support software-controlled clock modulation. This provides a means for operating systems to implement a power management policy to reduce the power consumption of the processor. Here, the stop-clock duty cycle is controlled by software through the IA32\_CLOCK\_MODULATION MSR (see Figure 14-10).



**Figure 14-10. IA32\_CLOCK\_MODULATION MSR**

The IA32\_CLOCK\_MODULATION MSR contains the following flag and field used to enable software-controlled clock modulation and to select the clock modulation duty cycle:

- **On-Demand Clock Modulation Enable, bit 4** — Enables on-demand software controlled clock modulation when set; disables software-controlled clock modulation when clear.
- **On-Demand Clock Modulation Duty Cycle, bits 1 through 3** — Selects the on-demand clock modulation duty cycle (see Table 14-1). This field is only active when the on-demand clock modulation enable flag is set.

Note that the on-demand clock modulation mechanism (like the thermal monitor) controls the processor's stop-clock circuitry internally to modulate the clock signal. The STPCLK# pin is not used in this mechanism.

**Table 14-1. On-Demand Clock Modulation Duty Cycle Field Encoding**

Duty Cycle Field Encoding	Duty Cycle
000B	Reserved
001B	12.5% (Default)
010B	25.0%
011B	37.5%
100B	50.0%
101B	63.5%
110B	75%
111B	87.5%

The on-demand clock modulation mechanism can be used to control processor power consumption. Power management software can write to the IA32\_CLOCK\_MODULATION MSR to enable clock modulation and to select a modulation duty cycle. If on-demand clock modulation and TM1 are both enabled and the thermal status of the processor is hot (bit 0 of the IA32\_THERM\_STATUS MSR is set),

clock modulation at the duty cycle specified by TM1 takes precedence, regardless of the setting of the on-demand clock modulation duty cycle.

For Hyper-Threading Technology enabled processors, the IA32\_CLOCK\_MODULATION register is duplicated for each logical processor. In order for the On-demand clock modulation feature to work properly, the feature must be enabled on all the logical processors within a physical processor. If the programmed duty cycle is not identical for all the logical processors, the processor clock will modulate to the highest duty cycle programmed.

For the P6 family processors, on-demand clock modulation was implemented through the chipset, which controlled clock modulation through the processor’s STPCLK# pin.

### 14.5.3.1 Extension of Software Controlled Clock Modulation

Extension of the software controlled clock modulation facility supports on-demand clock modulation duty cycle with 4-bit dynamic range (increased from 3-bit range). Granularity of clock modulation duty cycle is increased to 6.25% (compared to 12.5%).

Four bit dynamic range control is provided by using bit 0 in conjunction with bits 3:1 of the IA32\_CLOCK\_MODULATION MSR (see Figure 14-11).

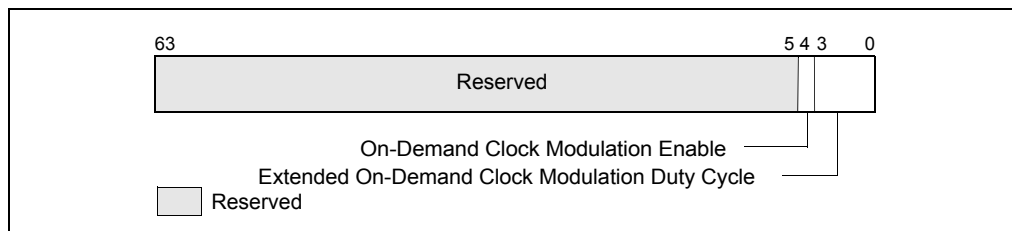


Figure 14-11. IA32\_CLOCK\_MODULATION MSR with Clock Modulation Extension

Extension to software controlled clock modulation is supported only if CPUID.06H:EAX[Bit 5] = 1. If CPUID.06H:EAX[Bit 5] = 0, then bit 0 of IA32\_CLOCK\_MODULATION is reserved.

### 14.5.4 Detection of Thermal Monitor and Software Controlled Clock Modulation Facilities

The ACPI flag (bit 22) of the CPUID feature flags indicates the presence of the IA32\_THERM\_STATUS, IA32\_THERM\_INTERRUPT, IA32\_CLOCK\_MODULATION MSRs, and the xAPIC thermal LVT entry.

The TM1 flag (bit 29) of the CPUID feature flags indicates the presence of the automatic thermal monitoring facilities that modulate clock duty cycles.

### 14.5.4.1 Detection of Software Controlled Clock Modulation Extension

Processor's support of software controlled clock modulation extension is indicated by CPUID.06H:EAX[Bit 5] = 1.

## 14.5.5 On Die Digital Thermal Sensors

On die digital thermal sensor can be read using an MSR (no I/O interface). In Intel Core Duo processors, each core has a unique digital sensor whose temperature is accessible using an MSR. The digital thermal sensor is the preferred method for reading the die temperature because (a) it is located closer to the hottest portions of the die, (b) it enables software to accurately track the die temperature and the potential activation of thermal throttling.

### 14.5.5.1 Digital Thermal Sensor Enumeration

The processor supports a digital thermal sensor if CPUID.06H.EAX[0] = 1. If the processor supports digital thermal sensor, EBX[bits 3:0] determine the number of thermal thresholds that are available for use.

Software sets thermal thresholds by using the IA32\_THERM\_INTERRUPT MSR. Software reads output of the digital thermal sensor using the IA32\_THERM\_STATUS MSR.

### 14.5.5.2 Reading the Digital Sensor

Unlike traditional analog thermal devices, the output of the digital thermal sensor is a temperature relative to the maximum supported operating temperature of the processor.

Temperature measurements returned by digital thermal sensors are always at or below TCC activation temperature. Critical temperature conditions are detected using the "Critical Temperature Status" bit. When this bit is set, the processor is operating at a critical temperature and immediate shutdown of the system should occur. Once the "Critical Temperature Status" bit is set, reliable operation is not guaranteed.

See Figure 14-12 for the layout of IA32\_THERM\_STATUS MSR. Bit fields include:

- **Thermal Status (bit 0, RO)** — This bit indicates whether the digital thermal sensor high-temperature output signal (PROCHOT#) is currently active. Bit 0 = 1 indicates the feature is active. This bit may not be written by software; it reflects the state of the digital thermal sensor.
- **Thermal Status Log (bit 1, R/WC0)** — This is a sticky bit that indicates the history of the thermal sensor high temperature output signal (PROCHOT#). Bit 1 = 1 if PROCHOT# has been asserted since a previous RESET or the last time software cleared the bit. Software may clear this bit by writing a zero.

- PROCHOT# or FORCEPR# Event (bit 2, RO)** — Indicates whether PROCHOT# or FORCEPR# is being asserted by another agent on the platform.

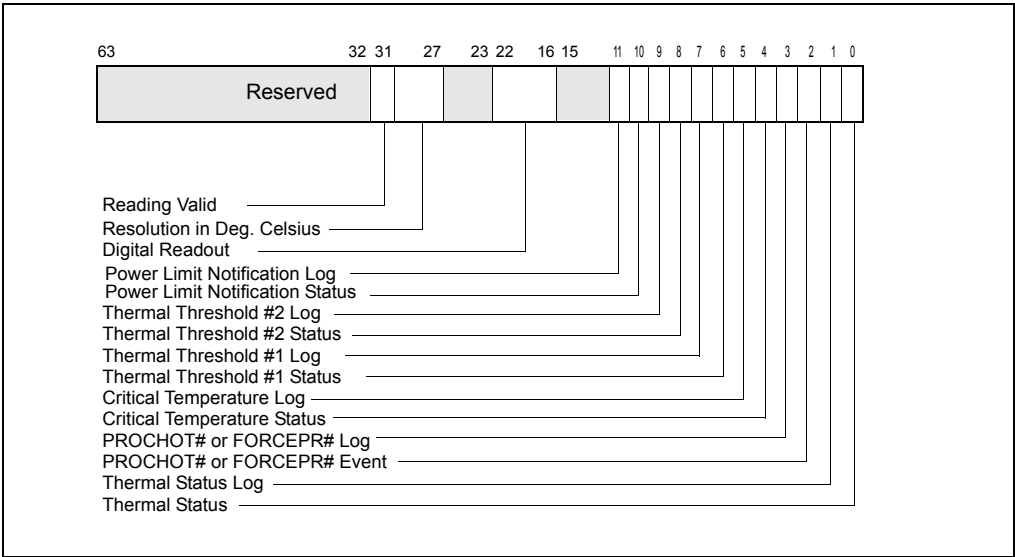


Figure 14-12. IA32\_THERM\_STATUS Register

- PROCHOT# or FORCEPR# Log (bit 3, R/WC0)** — Sticky bit that indicates whether PROCHOT# or FORCEPR# has been asserted by another agent on the platform since the last clearing of this bit or a reset. If bit 3 = 1, PROCHOT# or FORCEPR# has been externally asserted. Software may clear this bit by writing a zero. External PROCHOT# assertions are only acknowledged if the Bidirectional Prochot feature is enabled.
- Critical Temperature Status (bit 4, RO)** — Indicates whether the critical temperature detector output signal is currently active. If bit 4 = 1, the critical temperature detector output signal is currently active.
- Critical Temperature Log (bit 5, R/WC0)** — Sticky bit that indicates whether the critical temperature detector output signal has been asserted since the last clearing of this bit or reset. If bit 5 = 1, the output signal has been asserted. Software may clear this bit by writing a zero.
- Thermal Threshold #1 Status (bit 6, RO)** — Indicates whether the actual temperature is currently higher than or equal to the value set in Thermal Threshold #1. If bit 6 = 0, the actual temperature is lower. If bit 6 = 1, the actual temperature is greater than or equal to TT#1. Quantitative information of actual temperature can be inferred from Digital Readout, bits 22:16.
- Thermal Threshold #1 Log (bit 7, R/WC0)** — Sticky bit that indicates whether the Thermal Threshold #1 has been reached since the last clearing of

this bit or a reset. If bit 7 = 1, the Threshold #1 has been reached. Software may clear this bit by writing a zero.

- **Thermal Threshold #2 Status (bit 8, RO)** — Indicates whether actual temperature is currently higher than or equal to the value set in Thermal Threshold #2. If bit 8 = 0, the actual temperature is lower. If bit 8 = 1, the actual temperature is greater than or equal to TT#2. Quantitative information of actual temperature can be inferred from Digital Readout, bits 22:16.
- **Thermal Threshold #2 Log (bit 9, R/WCO)** — Sticky bit that indicates whether the Thermal Threshold #2 has been reached since the last clearing of this bit or a reset. If bit 9 = 1, the Thermal Threshold #2 has been reached. Software may clear this bit by writing a zero.
- **Power Limitation Status (bit 10, RO)** — Indicates whether the processor is currently operating below OS-requested P-state (specified in IA32\_PERF\_CTL) or OS-requested clock modulation duty cycle (specified in IA32\_CLOCK\_MODULATION). This field is supported only if CPUID.06H:EAX[bit 4] = 1. Package level power limit notification can be delivered independently to IA32\_PACKAGE\_THERM\_STATUS MSR.
- **Power Notification Log (bit 11, R/WCO)** — Sticky bit that indicates the processor went below OS-requested P-state or OS-requested clock modulation duty cycle since the last clearing of this or RESET. This field is supported only if CPUID.06H:EAX[bit 4] = 1. Package level power limit notification is indicated independently in IA32\_PACKAGE\_THERM\_STATUS MSR.
- **Digital Readout (bits 22:16, RO)** — Digital temperature reading in 1 degree Celsius relative to the TCC activation temperature.  
0: TCC Activation temperature,  
1: (TCC Activation - 1) , etc. See the processor's data sheet for details regarding TCC activation.  
A lower reading in the Digital Readout field (bits 22:16) indicates a higher actual temperature.
- **Resolution in Degrees Celsius (bits 30:27, RO)** — Specifies the resolution (or tolerance) of the digital thermal sensor. The value is in degrees Celsius. It is recommended that new threshold values be offset from the current temperature by at least the resolution + 1 in order to avoid hysteresis of interrupt generation.
- **Reading Valid (bit 31, RO)** — Indicates if the digital readout in bits 22:16 is valid. The readout is valid if bit 31 = 1.

Changes to temperature can be detected using two thresholds (see Figure 14-13); one is set above and the other below the current temperature. These thresholds have the capability of generating interrupts using the core's local APIC which software must then service. Note that the local APIC entries used by these thresholds are also used by the Intel® Thermal Monitor; it is up to software to determine the source of a specific interrupt.

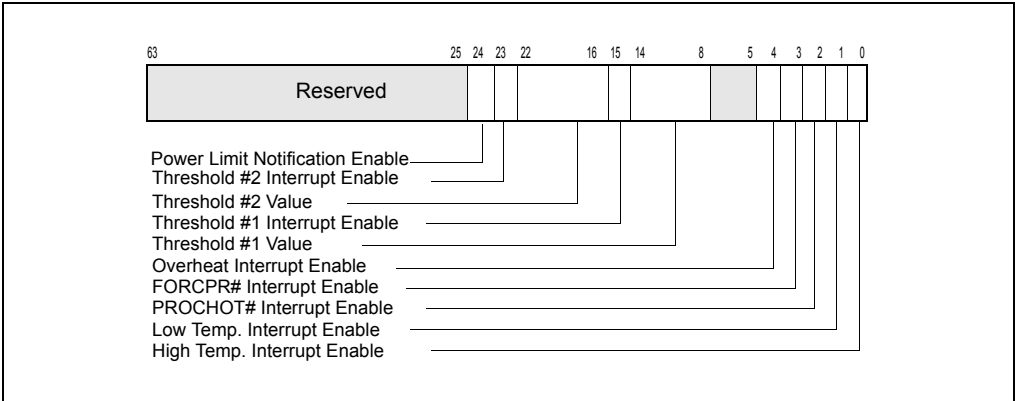


Figure 14-13. IA32\_THERM\_INTERRUPT Register

See Figure 14-13 for the layout of IA32\_THERM\_INTERRUPT MSR. Bit fields include:

- **High-Temperature Interrupt Enable (bit 0, R/W)** — This bit allows the BIOS to enable the generation of an interrupt on the transition from low-temperature to a high-temperature threshold. Bit 0 = 0 (default) disables interrupts; bit 0 = 1 enables interrupts.
- **Low-Temperature Interrupt Enable (bit 1, R/W)** — This bit allows the BIOS to enable the generation of an interrupt on the transition from high-temperature to a low-temperature (TCC de-activation). Bit 1 = 0 (default) disables interrupts; bit 1 = 1 enables interrupts.
- **PROCHOT# Interrupt Enable (bit 2, R/W)** — This bit allows the BIOS or OS to enable the generation of an interrupt when PROCHOT# has been asserted by another agent on the platform and the Bidirectional Prochot feature is enabled. Bit 2 = 0 disables the interrupt; bit 2 = 1 enables the interrupt.
- **FORCEPR# Interrupt Enable (bit 3, R/W)** — This bit allows the BIOS or OS to enable the generation of an interrupt when FORCEPR# has been asserted by another agent on the platform. Bit 3 = 0 disables the interrupt; bit 3 = 1 enables the interrupt.
- **Critical Temperature Interrupt Enable (bit 4, R/W)** — Enables the generation of an interrupt when the Critical Temperature Detector has detected a critical thermal condition. The recommended response to this condition is a system shutdown. Bit 4 = 0 disables the interrupt; bit 4 = 1 enables the interrupt.
- **Threshold #1 Value (bits 14:8, R/W)** — A temperature threshold, encoded relative to the TCC Activation temperature (using the same format as the Digital Readout). This threshold is compared against the Digital Readout and is used to



generate the Thermal Threshold #1 Status and Log bits as well as the Threshold #1 thermal interrupt delivery.

- **Threshold #1 Interrupt Enable (bit 15, R/W)** — Enables the generation of an interrupt when the actual temperature crosses the Threshold #1 setting in any direction. Bit 15 = 0 enables the interrupt; bit 15 = 1 disables the interrupt.
- **Threshold #2 Value (bits 22:16, R/W)** —A temperature threshold, encoded relative to the TCC Activation temperature (using the same format as the Digital Readout). This threshold is compared against the Digital Readout and is used to generate the Thermal Threshold #2 Status and Log bits as well as the Threshold #2 thermal interrupt delivery.
- **Threshold #2 Interrupt Enable (bit 23, R/W)** — Enables the generation of an interrupt when the actual temperature crosses the Threshold #2 setting in any direction. Bit 23 = 0 enables the interrupt; bit 23 = 1 disables the interrupt.
- **Power Limit Notification Enable (bit 24, R/W)** — Enables the generation of power notification events when the processor went below OS-requested P-state or OS-requested clock modulation duty cycle. This field is supported only if CPUID.06H:EAX[bit 4] = 1. Package level power limit notification can be enabled independently by IA32\_PACKAGE\_THERM\_INTERRUPT MSR.

### 14.5.6 Power Limit Notification

Platform firmware may be capable of specifying a power limit to restrict power delivered to a platform component, such as a physical processor package. This constraint imposed by platform firmware may occasionally cause the processor to operate below OS-requested P or T-state. A power limit notification event can be delivered using the existing thermal LVT entry in the local APIC.

Software can enumerate the presence of the processor's support for power limit notification by verifying CPUID.06H:EAX[bit 4] = 1.

If CPUID.06H:EAX[bit 4] = 1, then IA32\_THERM\_INTERRUPT and IA32\_THERM\_STATUS provides the following facility to manage power limit notification:

- Bits 10 and 11 in IA32\_THERM\_STATUS informs software of the occurrence of processor operating below OS-requested P-state or clock modulation duty cycle setting (see Figure 14-12).
- Bit 24 in IA32\_THERM\_INTERRUPT enables the local APIC to deliver a thermal event when the processor went below OS-requested P-state or clock modulation duty cycle setting (see Figure 14-13).

## 14.6 PACKAGE LEVEL THERMAL MANAGEMENT

The thermal management facilities like IA32\_THERM\_INTERRUPT and IA32\_THERM\_STATUS are often implemented with a processor core granularity. To

facilitate software manage thermal events from a package level granularity, two architectural MSR is provided for package level thermal management. The IA32\_PACKAGE\_THERM\_STATUS and IA32\_PACKAGE\_THERM\_INTERRUPT MSRs use similar interfaces as IA32\_THERM\_STATUS and IA32\_THERM\_INTERRUPT, but are shared in each physical processor package.

Software can enumerate the presence of the processor’s support for package level thermal management facility (IA32\_PACKAGE\_THERM\_STATUS and IA32\_PACKAGE\_THERM\_INTERRUPT) by verifying CPUID.06H:EAX[bit 6] = 1.

The layout of IA32\_PACKAGE\_THERM\_STATUS MSR is shown in Figure 14-14.

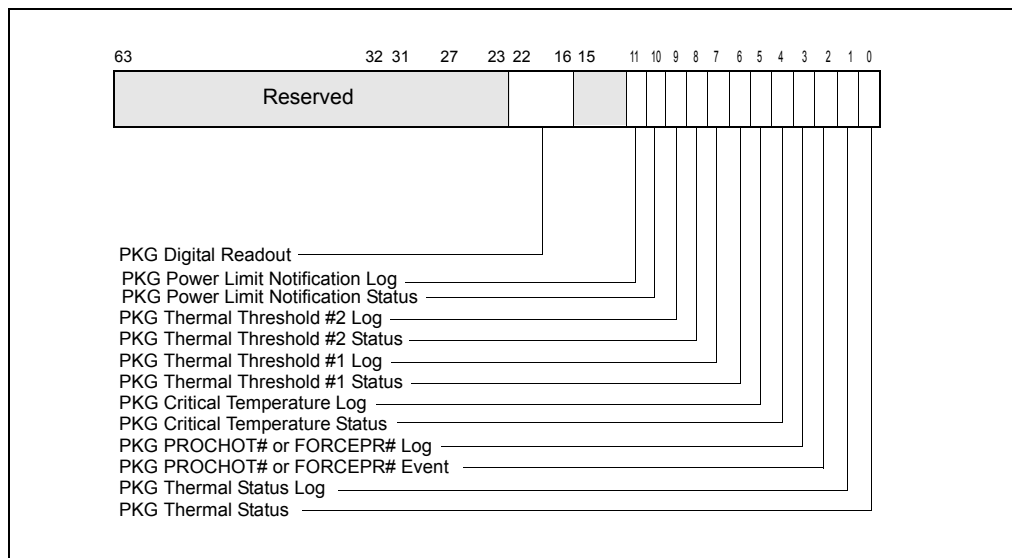


Figure 14-14. IA32\_PACKAGE\_THERM\_STATUS Register

- **Package Thermal Status (bit 0, RO)** — This bit indicates whether the digital thermal sensor high-temperature output signal (PROCHOT#) for the package is currently active. Bit 0 = 1 indicates the feature is active. This bit may not be written by software; it reflects the state of the digital thermal sensor.
- **Package Thermal Status Log (bit 1, R/WC0)** — This is a sticky bit that indicates the history of the thermal sensor high temperature output signal (PROCHOT#) of the package. Bit 1 = 1 if package PROCHOT# has been asserted since a previous RESET or the last time software cleared the bit. Software may clear this bit by writing a zero.
- **Package PROCHOT# Event (bit 2, RO)** — Indicates whether package PROCHOT# is being asserted by another agent on the platform.

- **Package PROCHOT# Log (bit 3, R/WC0)** — Sticky bit that indicates whether package PROCHOT# has been asserted by another agent on the platform since the last clearing of this bit or a reset. If bit 3 = 1, package PROCHOT# has been externally asserted. Software may clear this bit by writing a zero.
- **Package Critical Temperature Status (bit 4, RO)** — Indicates whether the package critical temperature detector output signal is currently active. If bit 4 = 1, the package critical temperature detector output signal is currently active.
- **Package Critical Temperature Log (bit 5, R/WC0)** — Sticky bit that indicates whether the package critical temperature detector output signal has been asserted since the last clearing of this bit or reset. If bit 5 = 1, the output signal has been asserted. Software may clear this bit by writing a zero.
- **Package Thermal Threshold #1 Status (bit 6, RO)** — Indicates whether the actual package temperature is currently higher than or equal to the value set in Package Thermal Threshold #1. If bit 6 = 0, the actual temperature is lower. If bit 6 = 1, the actual temperature is greater than or equal to PTT#1. Quantitative information of actual package temperature can be inferred from Package Digital Readout, bits 22:16.
- **Package Thermal Threshold #1 Log (bit 7, R/WC0)** — Sticky bit that indicates whether the Package Thermal Threshold #1 has been reached since the last clearing of this bit or a reset. If bit 7 = 1, the Package Threshold #1 has been reached. Software may clear this bit by writing a zero.
- **Package Thermal Threshold #2 Status (bit 8, RO)** — Indicates whether actual package temperature is currently higher than or equal to the value set in Package Thermal Threshold #2. If bit 8 = 0, the actual temperature is lower. If bit 8 = 1, the actual temperature is greater than or equal to PTT#2. Quantitative information of actual temperature can be inferred from Package Digital Readout, bits 22:16.
- **Package Thermal Threshold #2 Log (bit 9, R/WC0)** — Sticky bit that indicates whether the Package Thermal Threshold #2 has been reached since the last clearing of this bit or a reset. If bit 9 = 1, the Package Thermal Threshold #2 has been reached. Software may clear this bit by writing a zero.
- **Package Power Limitation Status (bit 10, RO)** — Indicates package power limit is forcing one or more processors to operate below OS-requested P-state. Note that package power limit violation may be caused by processor cores or by devices residing in the uncore. Software can examine IA32\_THERM\_STATUS to determine if the cause originates from a processor core (see Figure 14-12).
- **Package Power Notification Log (bit 11, R/WC0)** — Sticky bit that indicates any processor in the package went below OS-requested P-state or OS-requested clock modulation duty cycle since the last clearing of this or RESET.
- **Package Digital Readout (bits 22:16, RO)** — Package digital temperature reading in 1 degree Celsius relative to the package TCC activation temperature.  
0: Package TCC Activation temperature,

1: (PTCC Activation - 1) , etc. See the processor’s data sheet for details regarding PTCC activation.

A lower reading in the Package Digital Readout field (bits 22:16) indicates a higher actual temperature.

The layout of IA32\_PACKAGE\_THERM\_INTERRUPT MSR is shown in Figure 14-15.

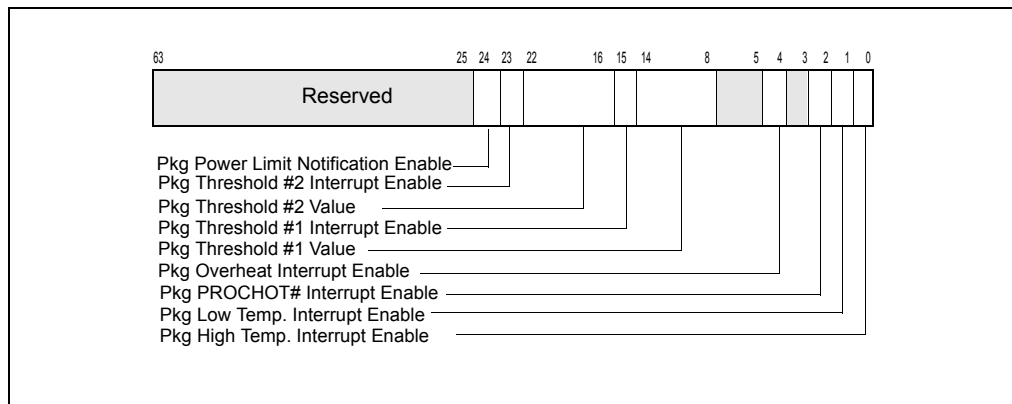


Figure 14-15. IA32\_PACKAGE\_THERM\_INTERRUPT Register

- Package High-Temperature Interrupt Enable (bit 0, R/W)** — This bit allows the BIOS to enable the generation of an interrupt on the transition from low-temperature to a package high-temperature threshold. Bit 0 = 0 (default) disables interrupts; bit 0 = 1 enables interrupts.
- Package Low-Temperature Interrupt Enable (bit 1, R/W)** — This bit allows the BIOS to enable the generation of an interrupt on the transition from high-temperature to a low-temperature (TCC de-activation). Bit 1 = 0 (default) disables interrupts; bit 1 = 1 enables interrupts.
- Package PROCHOT# Interrupt Enable (bit 2, R/W)** — This bit allows the BIOS or OS to enable the generation of an interrupt when Package PROCHOT# has been asserted by another agent on the platform and the Bidirectional Prochot feature is enabled. Bit 2 = 0 disables the interrupt; bit 2 = 1 enables the interrupt.
- Package Critical Temperature Interrupt Enable (bit 4, R/W)** — Enables the generation of an interrupt when the Package Critical Temperature Detector has detected a critical thermal condition. The recommended response to this condition is a system shutdown. Bit 4 = 0 disables the interrupt; bit 4 = 1 enables the interrupt.
- Package Threshold #1 Value (bits 14:8, R/W)** — A temperature threshold, encoded relative to the Package TCC Activation temperature (using the same format as the Digital Readout). This threshold is compared against the Package

Digital Readout and is used to generate the Package Thermal Threshold #1 Status and Log bits as well as the Package Thermal Threshold #1 thermal interrupt delivery.

- **Package Thermal Threshold #1 Interrupt Enable (bit 15, R/W)** — Enables the generation of an interrupt when the actual temperature crosses the Package Thermal Threshold #1 setting in any direction. Bit 15 = 0 enables the interrupt; bit 15 = 1 disables the interrupt.
- **Package Thermal Threshold #2 Value (bits 22:16, R/W)** — A temperature threshold, encoded relative to the PTCC Activation temperature (using the same format as the Package Digital Readout). This threshold is compared against the Package Digital Readout and is used to generate the Package Thermal Threshold #2 Status and Log bits as well as the Package Thermal Threshold #2 thermal interrupt delivery.
- **Package Thermal Threshold #2 Interrupt Enable (bit 23, R/W)** — Enables the generation of an interrupt when the actual temperature crosses the Package Thermal Threshold #2 setting in any direction. Bit 23 = 0 enables the interrupt; bit 23 = 1 disables the interrupt.
- **Package Power Limit Notification Enable (bit 24, R/W)** — Enables the generation of package power notification events.

### 14.6.1 Support for Passive and Active cooling

Passive and active cooling may be controlled by the OS power management agent through ACPI control methods. On platforms providing package level thermal management facility described in the previous section, it is recommended that active cooling (FAN control) should be driven by measuring the package temperature using the IA32\_PACKAGE\_THERM\_INTERRUPT MSR.

Passive cooling (frequency throttling) should be driven by measuring (a) the core and package temperatures, or (b) only the package temperature. If measured package temperature led the power management agent to choose which core to execute passive cooling, then all cores need to execute passive cooling. Core temperature is measured using the IA32\_THERMAL\_STATUS and IA32\_THERMAL\_INTERRUPT MSRs. The exact implementation details depend on the platform firmware and possible solutions include defining two different thermal zones (one for core temperature and passive cooling and the other for package temperature and active cooling).

## 14.7 PLATFORM SPECIFIC POWER MANAGEMENT SUPPORT

This section covers power management interfaces that are not architectural but addresses the power management needs of several platform specific components.

Specifically, RAPL (Running Average Power Limit) interfaces provide mechanisms to enforce power consumption limit. Power limiting usages have specific usages in client and server platforms.

For client platform power limit control and for server platforms used in a data center, the following power and thermal related usages are desirable:

- Platform Thermal Management: Robust mechanisms to manage component, platform, and group-level thermals, either proactively or reactively (e.g., in response to a platform-level thermal trip point).
- Platform Power Limiting: More deterministic control over the system's power consumption, for example to meet battery life targets on rack- or container-level power consumption goals within a datacenter.
- Power/Performance Budgeting: Efficient means to control the power consumed (and therefore the sustained performance delivered) within and across platforms.

The server and client usage models are addressed by RAPL interfaces, which exposes multiple domains of power rationing within each processor socket. Generally, these RAPL domains may be viewed to include hierarchically:

- Package domain is the processor die.
- Memory domain include the directly-attached DRAM; additional power plane may constitutes a separate domain.

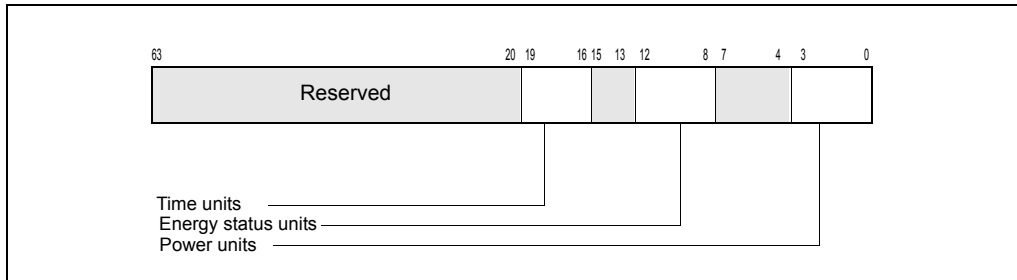
In order to manage the power consumed across multiple sockets via RAPL, individual limits must be programmed for each processor complex. Programming specific RAPL domain across multiple sockets is not supported.

### 14.7.1 RAPL Interfaces

RAPL interfaces consist of non-architectural MSRs. Each RAPL domain supports the following set of capabilities, some of which are optional as stated below.

- Power limit - MSR interfaces to specify power limit, time window; lock bit, clamp bit etc.
- Energy Status - Power metering interface providing energy consumption information.
- Perf Status (Optional) - Interface providing information on the performance effects (regression) due to power limits. It is defined as a duration metric that measures the power limit effect in the respective domain. The meaning of duration is domain specific.
- Power Info (Optional) - Interface providing information on the range of parameters for a given domain, minimum power, maximum power etc.
- Policy (Optional) - 4-bit priority information which is a hint to hardware for dividing budget between sub-domains in a parent domain.

Each of the above capabilities requires specific units in order to describe them. Power is expressed in Watts, Time is expressed in Seconds and Energy is expressed in Joules. Scaling factors are supplied to each unit to make the information presented meaningful in a finite number of bits. Units for power, energy and time are exposed in the read-only MSR\_RAPL\_POWER\_UNIT MSR.



**Figure 14-16. MSR\_RAPL\_POWER\_UNIT Register**

MSR\_RAPL\_POWER\_UNIT (Figure 14-16) provides the following information across all RAPL domains:

- **Power Units** (bits 3:0): Power related information (in Watts) is based on the multiplier,  $1/2^{\text{PU}}$ ; where PU is an unsigned integer represented by bits 3:0. Default value is 0011b, indicating power unit is in 1/8 Watts increment.
- **Energy Status Units** (bits 12:8): Energy related information (in Joules) is based on the multiplier,  $1/2^{\text{ESU}}$ ; where ESU is an unsigned integer represented by bits 12:8. Default value is 10000b, indicating energy status unit is in 15.3 micro-Joules increment.
- **Time Units** (bits 19:16): Time related information (in Seconds) is based on the multiplier,  $1/2^{\text{TU}}$ ; where TU is an unsigned integer represented by bits 19:16. Default value is 1010b, indicating time unit is in 976 micro-seconds increment.

## 14.7.2 RAPL Domains and Platform Specificity

The specific RAPL domains available in a platform varies across product segments. Platforms targeting client segment support the following RAPL domain hierarchy:

- Package
- Two power planes: PP0 and PP1 (PP1 may reflect to uncore devices)

Platforms targeting server segment support the following RAPL domain hierarchy:

- Package
- Power plane: PP0
- DRAM

Each level of the RAPL hierarchy provides respective set of RAPL interface MSRs. Table 14-2 lists the RAPL MSR interfaces available for each RAPL domain. The power limit MSR of each RAPL domain is located at offset 0 relative to an MSR base address which is non-architectural (see Chapter 34). The energy status MSR of each domain is located at offset 1 relative to the MSR base address of respective domain.

**Table 14-2. RAPL MSR Interfaces and RAPL Domains**

Domain	Power Limit (Offset 0)	Energy Status (Offset 1)	Policy (Offset 2)	Perf Status (Offset 3)	Power Info (Offset 4)
PKG	MSR_PKG_POWER_LIMIT	MSR_PKG_ENERGY_STATUS	RESERVED	MSR_PKG_RAPL_PERF_STATUS	MSR_PKG_POWER_INFO
DRAM	MSR_DRAM_POWER_LIMIT	MSR_DRAM_ENERGY_STATUS	RESERVED	MSR_DRAM_RAPL_PERF_STATUS	MSR_DRAM_POWER_INFO
PP0	MSR_PP0_POWER_LIMIT	MSR_PP0_ENERGY_STATUS	MSR_PP0_POLICY	RESERVED	RESERVED
PP1	MSR_PP1_POWER_LIMIT	MSR_PP1_ENERGY_STATUS	MSR_PP1_POLICY	RESERVED	RESERVED

The presence of the optional MSR interfaces (the three right-most columns of Table 14-2) may be model-specific. See Chapter 34 for detail.

### 14.7.3 Package RAPL Domain

The MSR interfaces defined for the package RAPL domain are:

- MSR\_PKG\_POWER\_LIMIT allows software to set power limits for the package and measurement attributes associated with each limit,
- MSR\_PKG\_ENERGY\_STATUS reports measured actual energy usage,
- MSR\_PKG\_POWER\_INFO reports the package power range information for RAPL usage.

MSR\_PKG\_RAPL\_PERF\_STATUS can report the performance impact of power limiting, but its availability may be model-specific.



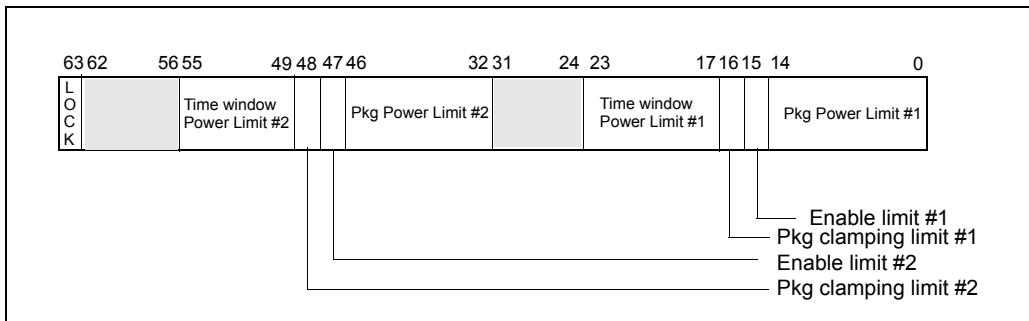


Figure 14-17. MSR\_PKG\_POWER\_LIMIT Register

MSR\_PKG\_POWER\_LIMIT allows a software agent to define power limitation for the package domain. Power limitation is defined in terms of average power usage (Watts) over a time window specified in MSR\_PKG\_POWER\_LIMIT. Two power limits can be specified, corresponding to time windows of different sizes. Each power limit provides independent clamping control that would permit the processor cores to go below OS-requested state to meet the power limits. A lock mechanism allow the software agent to enforce power limit settings. Once the lock bit is set, the power limit settings are static and un-modifiable until next RESET.

The bit fields of MSR\_PKG\_POWER\_LIMIT (Figure 14-17) are:

- **Package Power Limit #1**(bits 14:0): Sets the average power usage limit of the package domain corresponding to time window # 1. The unit of this field is specified by the "Power Units" field of MSR\_RAPL\_POWER\_UNIT.
- **Enable Power Limit #1**(bit 15): 0 = disabled; 1 = enabled.
- **Package Clamping Limitation #1** (bit 16): Allow going below OS-requested P/T state setting during time window specified by bits 23:17.
- **Time Window for Power Limit #1** (bits 23:17): Indicates the length of time window over which the power limit #1. The numeric value encoded by bits 23:17 is represented by the product of  $2^Y * F$ ; where F is a single-digit decimal floating-point value between 1.0 and 1.3 with the fraction digit represented by bits 23:22, Y is an unsigned integer represented by bits 21:17. The unit of this field is specified by the "Time Units" field of MSR\_RAPL\_POWER\_UNIT.
- **Package Power Limit #2**(bits 46:32): Sets the average power usage limit of the package domain corresponding to time window # 2. The unit of this field is specified by the "Power Units" field of MSR\_RAPL\_POWER\_UNIT.
- **Enable Power Limit #2**(bit 47): 0 = disabled; 1 = enabled.
- **Package Clamping Limitation #2** (bit 48): Allow going below OS-requested P/T state setting during time window specified by bits 23:17.

- Time Window for Power Limit #2** (bits 55:49): Indicates the length of time window over which the power limit #2. The numeric value encoded by bits 55:49 is represented by the product of  $2^Y * F$ ; where F is a single-digit decimal floating-point value between 1.0 and 1.3 with the fraction digit represented by bits 55:54, Y is an unsigned integer represented by bits 53:49. The unit of this field is specified by the "Time Units" field of MSR\_RAPL\_POWER\_UNIT. This field may have a hard-coded value in hardware and ignores values written by software.
- Lock** (bit 63): If set, all write attempts to this MSR are ignored until next RESET.

MSR\_PKG\_ENERGY\_STATUS is a read-only MSR. It reports the actual energy use for the package domain. This MSR is updated every ~1msec. It has a wraparound time of around 60 secs when power consumption is high, and may be longer otherwise.

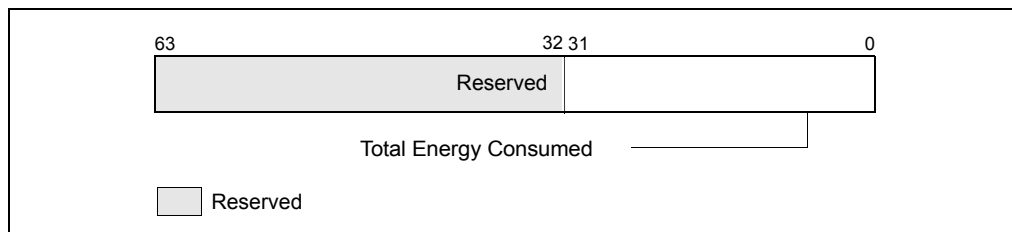


Figure 14-18. MSR\_PKG\_ENERGY\_STATUS MSR

- Total Energy Consumed** (bits 31:0): The unsigned integer value represents the total amount of energy consumed since that last time this register is cleared. The unit of this field is specified by the "Energy Status Units" field of MSR\_RAPL\_POWER\_UNIT.

MSR\_PKG\_POWER\_INFO is a read-only MSR. It reports the package power range information for RAPL usage. This MSR provides maximum/minimum values (derived from electrical specification), thermal specification power of the package domain. It also provides the largest possible time window for software to program the RAPL interface.

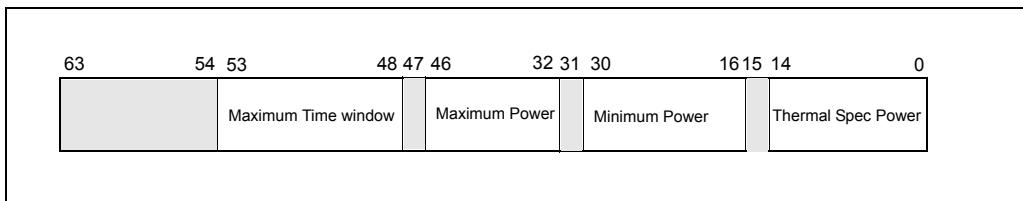


Figure 14-19. MSR\_PKG\_POWER\_INFO Register

- **Thermal Spec Power** (bits 14:0): The unsigned integer value is the equivalent of thermal specification power of the package domain. The unit of this field is specified by the “Power Units” field of MSR\_RAPL\_POWER\_UNIT.
- **Minimum Power** (bits 30:16): The unsigned integer value is the equivalent of minimum power derived from electrical spec of the package domain. The unit of this field is specified by the “Power Units” field of MSR\_RAPL\_POWER\_UNIT.
- **Maximum Power** (bits 46:32): The unsigned integer value is the equivalent of maximum power derived from the electrical spec of the package domain. The unit of this field is specified by the “Power Units” field of MSR\_RAPL\_POWER\_UNIT.
- **Maximum Time Window** (bits 53:48): The unsigned integer value is the equivalent of largest acceptable value to program the time window of MSR\_PKG\_POWER\_LIMIT. The unit of this field is specified by the “Time Units” field of MSR\_RAPL\_POWER\_UNIT.

MSR\_PKG\_PERF\_STATUS is a read-only MSR. It reports the total time for which the package was throttled due to the RAPL power limits. Throttling in this context is defined as going below the OS-requested P-state or T-state. It has a wrap-around time of many hours. The availability of this MSR is platform specific (see Chapter 34).

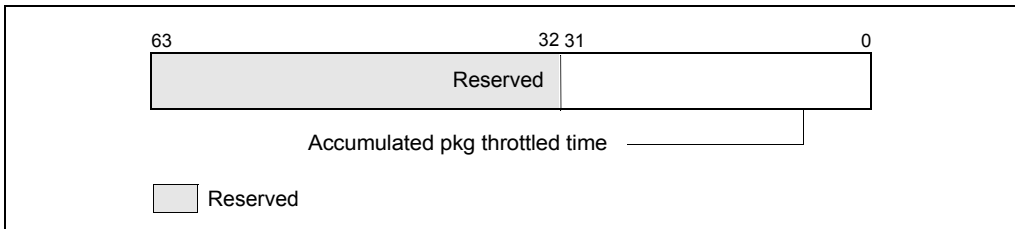


Figure 14-20. MSR\_PKG\_PERF\_STATUS MSR

- **Accumulated Package Throttled Time** (bits 31:0): The unsigned integer value represents the cumulative time (since the last time this register is cleared) that the package has throttled. The unit of this field is specified by the “Time Units” field of MSR\_RAPL\_POWER\_UNIT.

#### 14.7.4 PP0/PP1 RAPL Domains

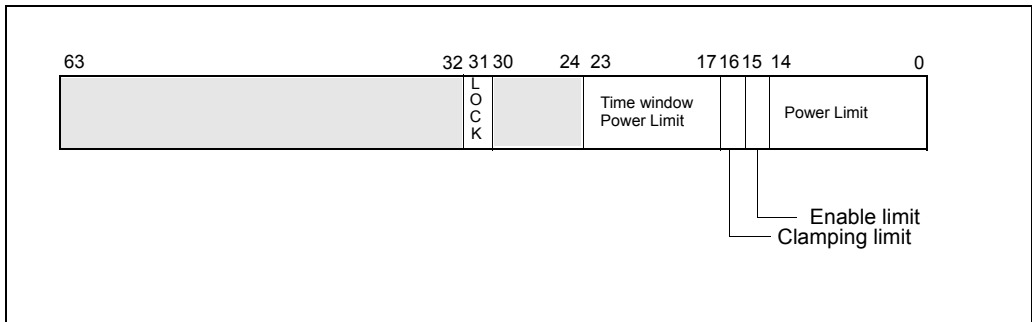
The MSR interfaces defined for the PP0 and PP1 domains are identical in layout. Generally, PP0 refers to the processor cores. The availability of PP1 RAPL domain interface is platform-specific. For a client platform, PP1 domain refers to the power plane of a specific device in the uncore. For server platforms, PP1 domain is not supported, but its PP0 domain supports the MSR\_PP0\_PERF\_STATUS interface.

- MSR\_PP0\_POWER\_LIMIT/MSR\_PP1\_POWER\_LIMIT allow software to set power limits for the respective power plane domain.

## POWER AND THERMAL MANAGEMENT

- MSR\_PP0\_ENERGY\_STATUS/MSR\_PP1\_ENERGY\_STATUS report actual energy usage on a power plane.
- MSR\_PP0\_POLICY/MSR\_PP1\_POLICY allow software to adjust balance for respective power plane.

MSR\_PP0\_PERF\_STATUS can report the performance impact of power limiting, but it is not available in client platform.



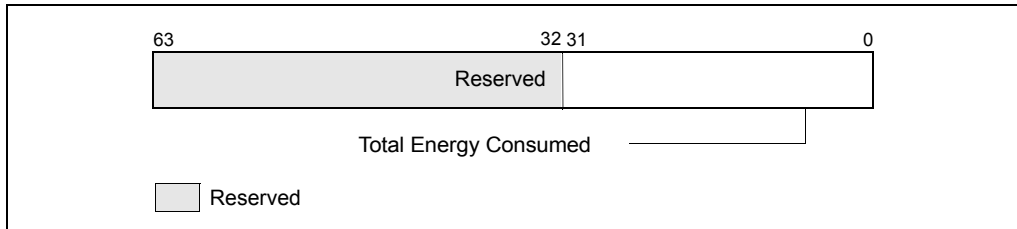
**Figure 14-21. MSR\_PP0\_POWER\_LIMIT/MSR\_PP1\_POWER\_LIMIT Register**

MSR\_PP0\_POWER\_LIMIT/MSR\_PP1\_POWER\_LIMIT allows a software agent to define power limitation for the respective power plane domain. A lock mechanism in each power plane domain allow the software agent to enforce power limit settings independently. Once a lock bit is set, the power limit settings in that power plane are static and un-modifiable until next RESET.

The bit fields of MSR\_PP0\_POWER\_LIMIT/MSR\_PP1\_POWER\_LIMIT (Figure 14-21) are:

- **Power Limit** (bits 14:0): Sets the average power usage limit of the respective power plane domain. The unit of this field is specified by the “Power Units” field of MSR\_RAPL\_POWER\_UNIT.
- **Enable Power Limit** (bit 15): 0 = disabled; 1 = enabled.
- **Clamping Limitation** (bit 16): Allow going below OS-requested P/T state setting during time window specified by bits 23:17.
- **Time Window for Power Limit** (bits 23:17): Indicates the length of time window over which the power limit #1 The numeric value encoded by bits 23:17 is represented by the product of  $2^Y * F$ ; where F is a single-digit decimal floating-point value between 1.0 and 1.3 with the fraction digit represented by bits 23:22, Y is an unsigned integer represented by bits 21:17. The unit of this field is specified by the “Time Units” field of MSR\_RAPL\_POWER\_UNIT.
- **Lock** (bit 31): If set, all write attempts to the MSR and corresponding policy MSR\_PP0\_POLICY/MSR\_PP1\_POLICY are ignored until next RESET.

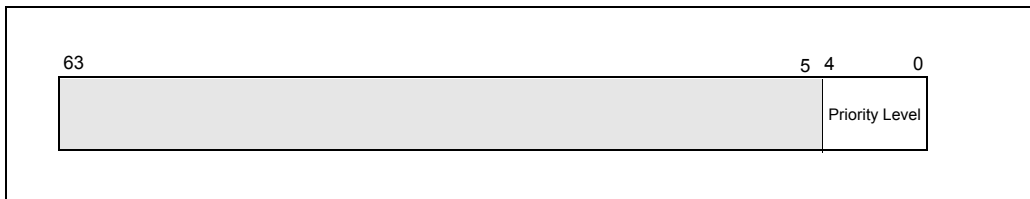
MSR\_PP0\_ENERGY\_STATUS/MSR\_PP1\_ENERGY\_STATUS is a read-only MSR. It reports the actual energy use for the respective power plane domain. This MSR is updated every ~1msec.



**Figure 14-22. MSR\_PP0\_ENERGY\_STATUS/MSR\_PP1\_ENERGY\_STATUS MSR**

- **Total Energy Consumed** (bits 31:0): The unsigned integer value represents the total amount of energy consumed since that last time this register is cleared. The unit of this field is specified by the “Energy Status Units” field of MSR\_RAPL\_POWER\_UNIT.

MSR\_PP0\_POLICY/MSR\_PP1\_POLICY provide balance power policy control for each power plane by providing inputs to the power budgeting management algorithm. On the platform that supports PP0 (IA cores) and PP1 (uncore graphic device), the default value give priority to the non-IA power plane. These MSRs enable the PCU to balance power consumption between the IA cores and uncore graphic device.



**Figure 14-23. MSR\_PP0\_POLICY/MSR\_PP1\_POLICY Register**

- **Priority Level** (bits 4:0): Priority level input to the PCU for respective power plane. PP0 covers the IA processor cores, PP1 covers the uncore graphic device. The value 31 is considered highest priority.

MSR\_PP0\_PERF\_STATUS is a read-only MSR. It reports the total time for which the PP0 domain was throttled due to the power limits. This MSR is supported only in server platform. Throttling in this context is defined as going below the OS-requested P-state or T-state.

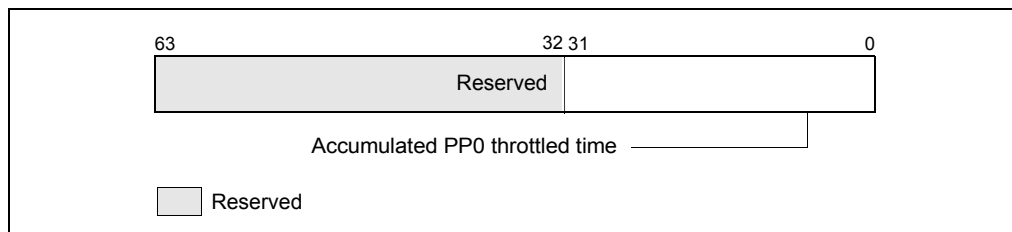


Figure 14-24. MSR\_PP0\_PERF\_STATUS MSR

- Accumulated PP0 Throttled Time** (bits 31:0): The unsigned integer value represents the cumulative time (since the last time this register is cleared) that the PP0 domain has throttled. The unit of this field is specified by the "Time Units" field of MSR\_RAPL\_POWER\_UNIT.

### 14.7.5 DRAM RAPL Domain

The MSR interfaces defined for the DRAM domain is supported only in the server platform. The MSR interfaces are:

- MSR\_DRAM\_POWER\_LIMIT allows software to set power limits for the DRAM domain and measurement attributes associated with each limit,
- MSR\_DRAM\_ENERGY\_STATUS reports measured actual energy usage,
- MSR\_DRAM\_POWER\_INFO reports the DRAM domain power range information for RAPL usage.
- MSR\_DRAM\_RAPL\_PERF\_STATUS can report the performance impact of power limiting.

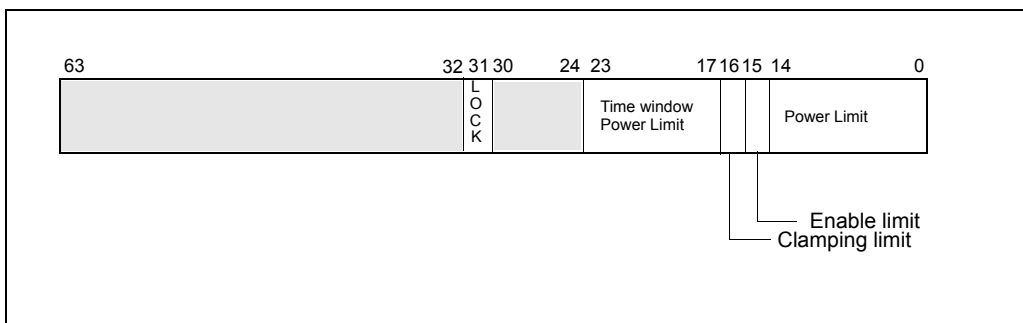


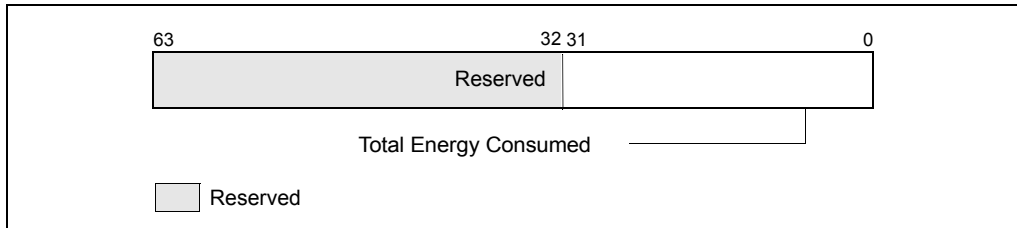
Figure 14-25. MSR\_DRAM\_POWER\_LIMIT Register

MSR\_DRAM\_POWER\_LIMIT allows a software agent to define power limitation for the DRAM domain. Power limitation is defined in terms of average power usage (Watts) over a time window specified in MSR\_DRAM\_POWER\_LIMIT. A power limit can be specified along with a time window. A lock mechanism allow the software agent to enforce power limit settings. Once the lock bit is set, the power limit settings are static and un-modifiable until next RESET.

The bit fields of MSR\_DRAM\_POWER\_LIMIT (Figure 14-25) are:

- **DRAM Power Limit #1**(bits 14:0): Sets the average power usage limit of the DRAM domain corresponding to time window # 1. The unit of this field is specified by the "Power Units" field of MSR\_RAPL\_POWER\_UNIT.
- **Enable Power Limit #1**(bit 15): 0 = disabled; 1 = enabled.
- **Time Window for Power Limit** (bits 23:17): Indicates the length of time window over which the power limit The numeric value encoded by bits 23:17 is represented by the product of  $2^Y * F$ ; where F is a single-digit decimal floating-point value between 1.0 and 1.3 with the fraction digit represented by bits 23:22, Y is an unsigned integer represented by bits 21:17. The unit of this field is specified by the "Time Units" field of MSR\_RAPL\_POWER\_UNIT.
- **Lock** (bit 31): If set, all write attempts to this MSR are ignored until next RESET.

MSR\_DRAM\_ENERGY\_STATUS is a read-only MSR. It reports the actual energy use for the DRAM domain. This MSR is updated every  $\sim 1$ msec.



**Figure 14-26. MSR\_DRAM\_ENERGY\_STATUS MSR**

- **Total Energy Consumed** (bits 31:0): The unsigned integer value represents the total amount of energy consumed since that last time this register is cleared. The unit of this field is specified by the "Energy Status Units" field of MSR\_RAPL\_POWER\_UNIT.

MSR\_DRAM\_POWER\_INFO is a read-only MSR. It reports the DRAM power range information for RAPL usage. This MSR provides maximum/minimum values (derived from electrical specification), thermal specification power of the DRAM domain. It

also provides the largest possible time window for software to program the RAPL interface.

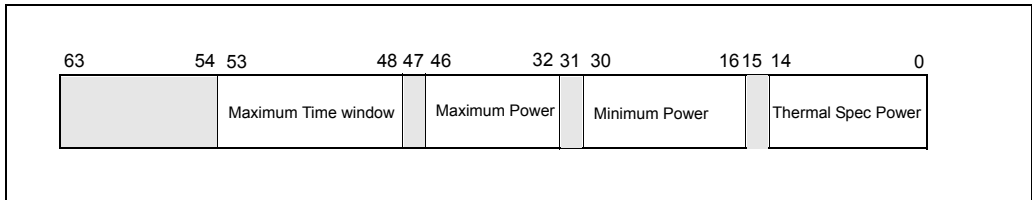


Figure 14-27. MSR\_DRAM\_POWER\_INFO Register

- **Thermal Spec Power** (bits 14:0): The unsigned integer value is the equivalent of thermal specification power of the DRAM domain. The unit of this field is specified by the “Power Units” field of MSR\_RAPL\_POWER\_UNIT.
- **Minimum Power** (bits 30:16): The unsigned integer value is the equivalent of minimum power derived from electrical spec of the DRAM domain. The unit of this field is specified by the “Power Units” field of MSR\_RAPL\_POWER\_UNIT.
- **Maximum Power** (bits 46:32): The unsigned integer value is the equivalent of maximum power derived from the electrical spec of the DRAM domain. The unit of this field is specified by the “Power Units” field of MSR\_RAPL\_POWER\_UNIT.
- **Maximum Time Window** (bits 53:48): The unsigned integer value is the equivalent of largest acceptable value to program the time window of MSR\_DRAM\_POWER\_LIMIT. The unit of this field is specified by the “Time Units” field of MSR\_RAPL\_POWER\_UNIT.

MSR\_DRAM\_PERF\_STATUS is a read-only MSR. It reports the total time for which the package was throttled due to the RAPL power limits. Throttling in this context is defined as going below the OS-requested P-state or T-state. It has a wrap-around time of many hours. The availability of this MSR is platform specific (see Chapter 34).

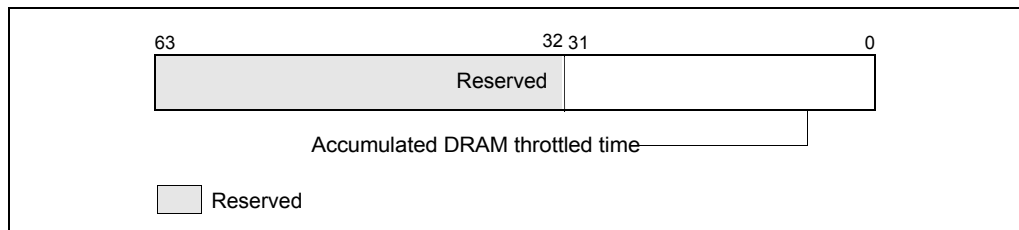


Figure 14-28. MSR\_DRAM\_PERF\_STATUS MSR

- **Accumulated Package Throttled Time** (bits 31:0): The unsigned integer value represents the cumulative time (since the last time this register is cleared)



that the DRAM domain has throttled. The unit of this field is specified by the "Time Units" field of MSR\_RAPL\_POWER\_UNIT.

# CHAPTER 15

## MACHINE-CHECK ARCHITECTURE

---

This chapter describes the machine-check architecture and machine-check exception mechanism found in the Pentium 4, Intel Xeon, and P6 family processors. See Chapter 6, “Interrupt 18—Machine-Check Exception (#MC),” for more information on machine-check exceptions. A brief description of the Pentium processor’s machine check capability is also given.

Additionally, a signaling mechanism for software to respond to hardware corrected machine check error is covered.

### 15.1 MACHINE-CHECK ARCHITECTURE

The Pentium 4, Intel Xeon, and P6 family processors implement a machine-check architecture that provides a mechanism for detecting and reporting hardware (machine) errors, such as: system bus errors, ECC errors, parity errors, cache errors, and TLB errors. It consists of a set of model-specific registers (MSRs) that are used to set up machine checking and additional banks of MSRs used for recording errors that are detected.

The processor signals the detection of an uncorrected machine-check error by generating a machine-check exception (#MC), which is an abort class exception. The implementation of the machine-check architecture does not ordinarily permit the processor to be restarted reliably after generating a machine-check exception. However, the machine-check-exception handler can collect information about the machine-check error from the machine-check MSRs.

Starting with 45nm Intel 64 processor on which CPUID reports DisplayFamily\_DisplayModel as 06H\_1AH (see CPUID instruction in Chapter 3, “Instruction Set Reference, A-L” in the *Intel® 64 and IA-32 Architectures Software Developer’s Manual, Volume 2A*), the processor can report information on corrected machine-check errors and deliver a programmable interrupt for software to respond to MC errors, referred to as corrected machine-check error interrupt (CMCI). See Section 15.5 for detail.

Intel 64 processors supporting machine-check architecture and CMCI may also support an additional enhancement, namely, support for software recovery from certain uncorrected recoverable machine check errors. See Section 15.6 for detail.

### 15.2 COMPATIBILITY WITH PENTIUM PROCESSOR

The Pentium 4, Intel Xeon, and P6 family processors support and extend the machine-check exception mechanism introduced in the Pentium processor. The Pentium processor reports the following machine-check errors:

- data parity errors during read cycles
- unsuccessful completion of a bus cycle

The above errors are reported using the P5\_MC\_TYPE and P5\_MC\_ADDR MSRs (implementation specific for the Pentium processor). Use the RDMSR instruction to read these MSRs. See Chapter 34, "Model-Specific Registers (MSRs)," for the addresses.

The machine-check error reporting mechanism that Pentium processors use is similar to that used in Pentium 4, Intel Xeon, and P6 family processors. When an error is detected, it is recorded in P5\_MC\_TYPE and P5\_MC\_ADDR; the processor then generates a machine-check exception (#MC).

See Section 15.3.3, "Mapping of the Pentium Processor Machine-Check Errors to the Machine-Check Architecture," and Section 15.10.2, "Pentium Processor Machine-Check Exception Handling," for information on compatibility between machine-check code written to run on the Pentium processors and code written to run on P6 family processors.

## 15.3 MACHINE-CHECK MSRS

Machine check MSRs in the Pentium 4, Intel Xeon, and P6 family processors consist of a set of global control and status registers and several error-reporting register banks. See Figure 15-1.

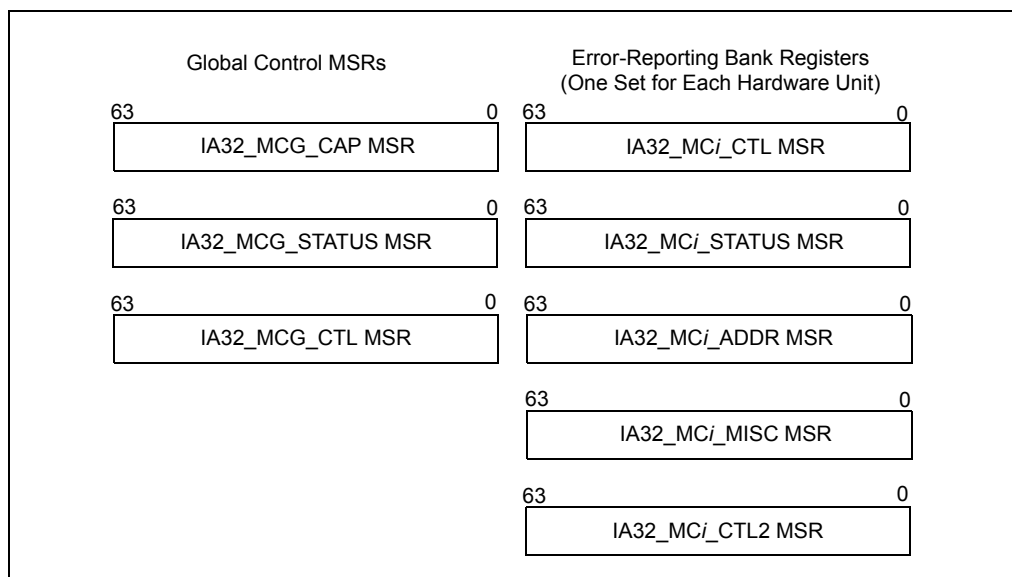


Figure 15-1. Machine-Check MSRs

Each error-reporting bank is associated with a specific hardware unit (or group of hardware units) in the processor. Use RDMSR and WRMSR to read and to write these registers.

## 15.3.1 Machine-Check Global Control MSRs

The machine-check global control MSRs include the IA32\_MCG\_CAP, IA32\_MCG\_STATUS, and IA32\_MCG\_CTL. See Chapter 34, “Model-Specific Registers (MSRs),” for the addresses of these registers.

### 15.3.1.1 IA32\_MCG\_CAP MSR

The IA32\_MCG\_CAP MSR is a read-only register that provides information about the machine-check architecture of the processor. Figure 15-2 shows the structure of the register in Pentium 4, Intel Xeon, and P6 family processors.

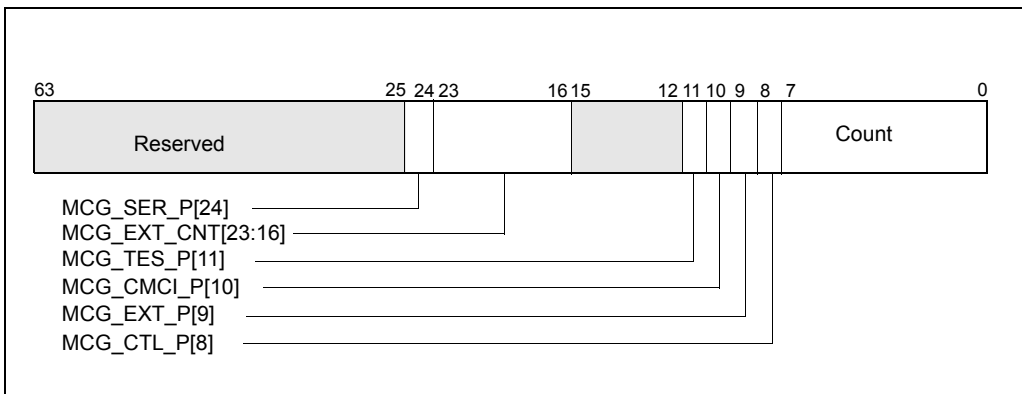


Figure 15-2. IA32\_MCG\_CAP Register

Where:

- **Count field, bits 7:0** — Indicates the number of hardware unit error-reporting banks available in a particular processor implementation.
- **MCG\_CTL\_P (control MSR present) flag, bit 8** — Indicates that the processor implements the IA32\_MCG\_CTL MSR when set; this register is absent when clear.
- **MCG\_EXT\_P (extended MSRs present) flag, bit 9** — Indicates that the processor implements the extended machine-check state registers found starting at MSR address 180H; these registers are absent when clear.
- **MCG\_CMCI\_P (Corrected MC error counting/signaling extension present) flag, bit 10** — Indicates (when set) that extended state and associated MSRs necessary to support the reporting of an interrupt on a

corrected MC error event and/or count threshold of corrected MC errors, is present. When this bit is set, it does not imply this feature is supported across all banks. Software should check the availability of the necessary logic on a bank by bank basis when using this signaling capability (i.e. bit 30 settable in individual IA32\_MCi\_CTL2 register).

- **MCG\_TES\_P (threshold-based error status present) flag, bit 11** — Indicates (when set) that bits 56:53 of the IA32\_MCi\_STATUS MSR are part of the architectural space. Bits 56:55 are reserved, and bits 54:53 are used to report threshold-based error status. Note that when MCG\_TES\_P is not set, bits 56:53 of the IA32\_MCi\_STATUS MSR are model-specific.
- **MCG\_EXT\_CNT, bits 23:16** — Indicates the number of extended machine-check state registers present. This field is meaningful only when the MCG\_EXT\_P flag is set.
- **MCG\_SER\_P (software error recovery support present) flag, bit 24**— Indicates (when set) that the processor supports software error recovery (see Section 15.6), and IA32\_MCi\_STATUS MSR bits 56:55 are used to report the signaling of uncorrected recoverable errors and whether software must take recovery actions for uncorrected errors. Note that when MCG\_TES\_P is not set, bits 56:53 of the IA32\_MCi\_STATUS MSR are model-specific. If MCG\_TES\_P is set but MCG\_SER\_P is not set, bits 56:55 are reserved.

The effect of writing to the IA32\_MCG\_CAP MSR is undefined.

### 15.3.1.2 IA32\_MCG\_STATUS MSR

The IA32\_MCG\_STATUS MSR describes the current state of the processor after a machine-check exception has occurred (see Figure 15-3).

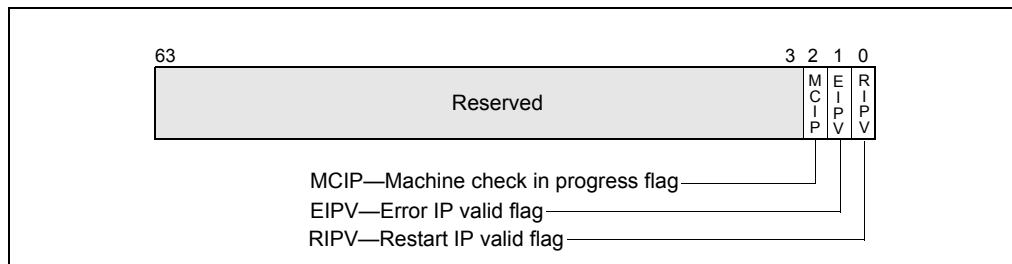


Figure 15-3. IA32\_MCG\_STATUS Register

Where:

- **RIPV (restart IP valid) flag, bit 0** — Indicates (when set) that program execution can be restarted reliably at the instruction pointed to by the instruction pointer pushed on the stack when the machine-check exception is generated.

When clear, the program cannot be reliably restarted at the pushed instruction pointer.

- **EIPV (error IP valid) flag, bit 1** — Indicates (when set) that the instruction pointed to by the instruction pointer pushed onto the stack when the machine-check exception is generated is directly associated with the error. When this flag is cleared, the instruction pointed to may not be associated with the error.
- **MCIP (machine check in progress) flag, bit 2** — Indicates (when set) that a machine-check exception was generated. Software can set or clear this flag. The occurrence of a second Machine-Check Event while MCIP is set will cause the processor to enter a shutdown state. For information on processor behavior in the shutdown state, please refer to the description in Chapter 6, “Interrupt and Exception Handling”: “Interrupt 8—Double Fault Exception (#DF)”.

Bits 63:03 in IA32\_MCG\_STATUS are reserved.

### 15.3.1.3 IA32\_MCG\_CTL MSR

The IA32\_MCG\_CTL MSR is present if the capability flag MCG\_CTL\_P is set in the IA32\_MCG\_CAP MSR.

IA32\_MCG\_CTL controls the reporting of machine-check exceptions. If present, writing 1s to this register enables machine-check features and writing all 0s disables machine-check features. All other values are undefined and/or implementation specific.

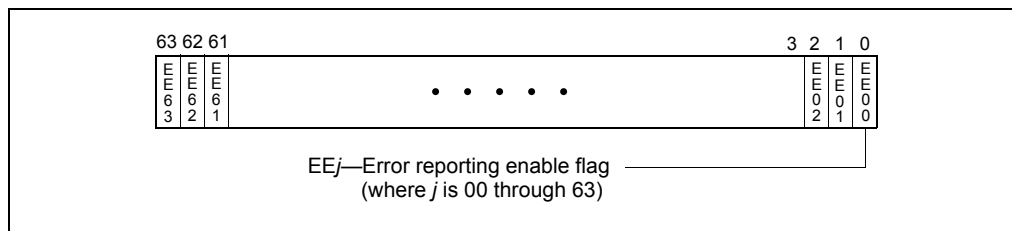
## 15.3.2 Error-Reporting Register Banks

Each error-reporting register bank can contain the IA32\_MCi\_CTL, IA32\_MCi\_STATUS, IA32\_MCi\_ADDR, and IA32\_MCi\_MISC MSRs. The number of reporting banks is indicated by bits [7:0] of IA32\_MCG\_CAP MSR (address 0179H). The first error-reporting register (IA32\_MC0\_CTL) always starts at address 400H.

See Chapter 34, “Model-Specific Registers (MSRs),” for addresses of the error-reporting registers in the Pentium 4 and Intel Xeon processors; and for addresses of the error-reporting registers P6 family processors.

### 15.3.2.1 IA32\_MCi\_CTL MSRs

The IA32\_MCi\_CTL MSR controls error reporting for errors produced by a particular hardware unit (or group of hardware units). Each of the 64 flags (EE<sub>j</sub>) represents a potential error. Setting an EE<sub>j</sub> flag enables reporting of the associated error and clearing it disables reporting of the error. The processor does not write changes to bits that are not implemented. Figure 15-4 shows the bit fields of IA32\_MCi\_CTL.



**Figure 15-4. IA32\_MCi\_CTL Register**

**NOTE**

For P6 family processors, processors based on Intel Core microarchitecture (excluding those on which on which CPUID reports DisplayFamily\_DisplayModel as 06H\_1AH and onward): the operating system or executive software must not modify the contents of the IA32\_MC0\_CTL MSR. This MSR is internally aliased to the EBL\_CR\_POWERON MSR and controls platform-specific error handling features. System specific firmware (the BIOS) is responsible for the appropriate initialization of the IA32\_MC0\_CTL MSR. P6 family processors only allow the writing of all 1s or all 0s to the IA32\_MCi\_CTL MSR.

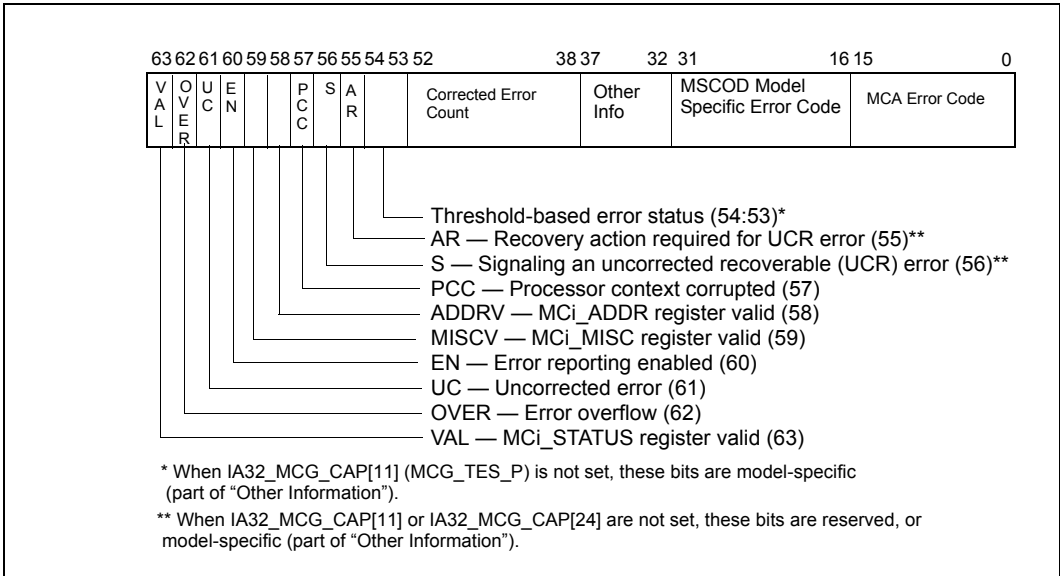
**15.3.2.2 IA32\_MCi\_STATUS MSRS**

Each IA32\_MCi\_STATUS MSR contains information related to a machine-check error if its VAL (valid) flag is set (see Figure 15-5). Software is responsible for clearing IA32\_MCi\_STATUS MSRs by explicitly writing 0s to them; writing 1s to them causes a general-protection exception.

**NOTE**

Figure 15-5 depicts the IA32\_MCi\_STATUS MSR when IA32\_MCG\_CAP[24] = 1, IA32\_MCG\_CAP[11] = 1 and IA32\_MCG\_CAP[10] = 1. When IA32\_MCG\_CAP[24] = 0 and IA32\_MCG\_CAP[11] = 1, bits 56:55 is reserved and bits 54:53 for threshold-based error reporting. When IA32\_MCG\_CAP[11] = 0, bits 56:53 are part of the “Other Information” field. The use of bits 54:53 for threshold-based error reporting began with Intel Core Duo processors, and is currently used for cache memory. See Section 15.4, “Enhanced Cache Error reporting,” for more information. When IA32\_MCG\_CAP[10] = 0, bits 52:38 are part of the “Other Information” field. The use of bits 52:38 for corrected MC error count is introduced with Intel 64 processor on which CPUID reports DisplayFamily\_DisplayModel as 06H\_1AH.

Where:



**Figure 15-5. IA32\_MCI\_STATUS Register**

- **MCA (machine-check architecture) error code field, bits 15:0** — Specifies the machine-check architecture-defined error code for the machine-check error condition detected. The machine-check architecture-defined error codes are guaranteed to be the same for all IA-32 processors that implement the machine-check architecture. See Section 15.9, "Interpreting the MCA Error Codes," and Chapter 16, "Interpreting Machine-Check Error Codes", for information on machine-check error codes.
- **Model-specific error code field, bits 31:16** — Specifies the model-specific error code that uniquely identifies the machine-check error condition detected. The model-specific error codes may differ among IA-32 processors for the same machine-check error condition. See Chapter 16, "Interpreting Machine-Check Error Codes" for information on model-specific error codes.
- **Reserved, Error Status, and Other Information fields, bits 56:32** —
  - Bits **37:32** always contain "Other Information" that is implementation-specific and is not part of the machine-check architecture. Software that is intended to be portable among IA-32 processors should not rely on these values.
  - If IA32\_MCG\_CAP[10] is 0, bits **52:38** also contain "Other Information" (in the same sense as bits 37:32).
  - If IA32\_MCG\_CAP[10] is 1, bits **52:38** are architectural (not model-specific). In this case, bits 52:38 reports the value of a 15 bit counter that increments each time a corrected error is observed by the MCA recording



bank. This count value will continue to increment until cleared by software. The most significant bit, 52, is a sticky count overflow bit.

- If IA32\_MCG\_CAP[11] is 0, bits **56:53** also contain “Other Information” (in the same sense).
- If IA32\_MCG\_CAP[11] is 1, bits **56:53** are architectural (not model-specific). In this case, bits 56:53 have the following functionality:
  - If IA32\_MCG\_CAP[24] is 0, bits 56:55 are reserved.
  - If IA32\_MCG\_CAP[24] is 1, bits 56:55 are defined as follows:
    - S (Signaling) flag, bit 56 - Signals the reporting of UCR errors in this MC bank. See Section 15.6.2 for additional detail.
    - AR (Action Required) flag, bit 55 - Indicates (when set) that MCA error code specific recovery action must be performed by system software at the time this error was signaled. See Section 15.6.2 for additional detail.
  - If the UC bit (Figure 15-5) is 1, bits 54:53 are undefined.
  - If the UC bit (Figure 15-5) is 0, bits 54:53 indicate the status of the hardware structure that reported the threshold-based error. See Table 15-1.

**Table 15-1. Bits 54:53 in IA32\_MCi\_STATUS MSRs when IA32\_MCG\_CAP[11] = 1 and UC = 0**

Bits 54:53	Meaning
00	<b>No tracking</b> - No hardware status tracking is provided for the structure reporting this event.
01	<b>Green</b> - Status tracking is provided for the structure posting the event; the current status is green (below threshold). For more information, see Section 15.4, “Enhanced Cache Error reporting”.
10	<b>Yellow</b> - Status tracking is provided for the structure posting the event; the current status is yellow (above threshold). For more information, see Section 15.4, “Enhanced Cache Error reporting”.
11	Reserved

- **PCC (processor context corrupt) flag, bit 57** — Indicates (when set) that the state of the processor might have been corrupted by the error condition detected and that reliable restarting of the processor may not be possible. When clear, this flag indicates that the error did not affect the processor’s state. Software restarting might be possible.
- **ADDRV (IA32\_MCi\_ADDR register valid) flag, bit 58** — Indicates (when set) that the IA32\_MCi\_ADDR register contains the address where the error occurred (see Section 15.3.2.3, “IA32\_MCi\_ADDR MSRs”). When clear, this flag indicates that the IA32\_MCi\_ADDR register is either not implemented or does not contain

the address where the error occurred. Do not read these registers if they are not implemented in the processor.

- **MISCV (IA32\_MCi\_MISC register valid) flag, bit 59** — Indicates (when set) that the IA32\_MCi\_MISC register contains additional information regarding the error. When clear, this flag indicates that the IA32\_MCi\_MISC register is either not implemented or does not contain additional information regarding the error. Do not read these registers if they are not implemented in the processor.
- **EN (error enabled) flag, bit 60** — Indicates (when set) that the error was enabled by the associated EE<sub>j</sub> bit of the IA32\_MCi\_CTL register.
- **UC (error uncorrected) flag, bit 61** — Indicates (when set) that the processor did not or was not able to correct the error condition. When clear, this flag indicates that the processor was able to correct the error condition.
- **OVER (machine check overflow) flag, bit 62** — Indicates (when set) that a machine-check error occurred while the results of a previous error were still in the error-reporting register bank (that is, the VAL bit was already set in the IA32\_MCi\_STATUS register). The processor sets the OVER flag and software is responsible for clearing it. In general, enabled errors are written over disabled errors, and uncorrected errors are written over corrected errors. Uncorrected errors are not written over previous valid uncorrected errors. For more information, see Section 15.3.2.2.1, “Overwrite Rules for Machine Check Overflow”.
- **VAL (IA32\_MCi\_STATUS register valid) flag, bit 63** — Indicates (when set) that the information within the IA32\_MCi\_STATUS register is valid. When this flag is set, the processor follows the rules given for the OVER flag in the IA32\_MCi\_STATUS register when overwriting previously valid entries. The processor sets the VAL flag and software is responsible for clearing it.

### 15.3.2.2.1 Overwrite Rules for Machine Check Overflow

Table 15-2 shows the overwrite rules for how to treat a second event if the cache has already posted an event to the MC bank – that is, what to do if the valid bit for an MC bank already is set to 1. When more than one structure posts events in a given bank, these rules specify whether a new event will overwrite a previous posting or not. These rules define a priority for uncorrected (highest priority), yellow, and green/unmonitored (lowest priority) status.

In Table 15-2, the values in the two left-most columns are IA32\_MCi\_STATUS[54:53].

**Table 15-2. Overwrite Rules for Enabled Errors**

First Event	Second Event	UC bit	Color	MCA Info
00/green	00/green	0	00/green	second
00/green	yellow	0	yellow	second error
yellow	00/green	0	yellow	first error
yellow	yellow	0	yellow	either

**Table 15-2. Overwrite Rules for Enabled Errors**

First Event	Second Event	UC bit	Color	MCA Info
00/green/yellow	UC	1	undefined	second
UC	00/green/yellow	1	undefined	first

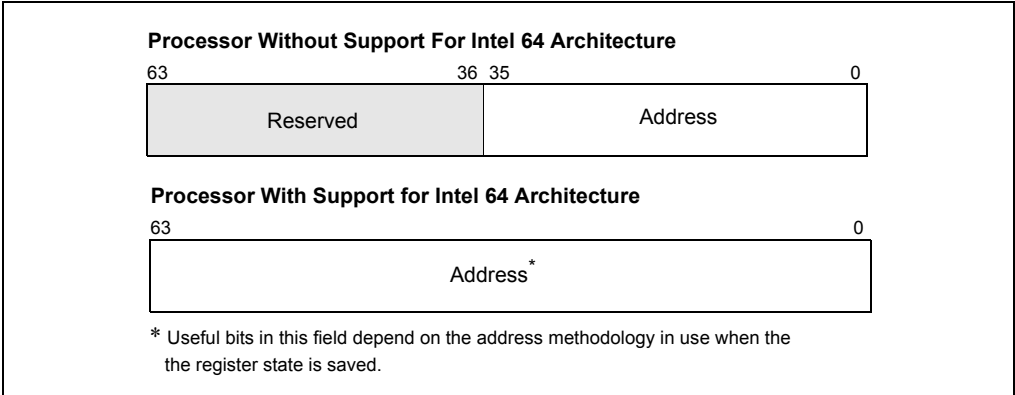
If a second event overwrites a previously posted event, the information (as guarded by individual valid bits) in the MCI bank is entirely from the second event. Similarly, if a first event is retained, all of the information previously posted for that event is retained. In either case, the OVER bit (MCI\_Status[62]) will be set to indicate an overflow.

After software polls a posting and clears the register, the valid bit is no longer set and therefore the meaning of the rest of the bits, including the yellow/green/00 status field in bits 54:53, is undefined. The yellow/green indication will only be posted for events associated with monitored structures – otherwise the unmonitored (00) code will be posted in MCI\_Status[54:53].

**15.3.2.3 IA32\_MCI\_ADDR MSRs**

The IA32\_MCI\_ADDR MSR contains the address of the code or data memory location that produced the machine-check error if the ADDR\_V flag in the IA32\_MCI\_STATUS register is set (see Section 15-6, "IA32\_MCI\_ADDR MSR"). The IA32\_MCI\_ADDR register is either not implemented or contains no address if the ADDR\_V flag in the IA32\_MCI\_STATUS register is clear. When not implemented in the processor, all reads and writes to this MSR will cause a general protection exception.

The address returned is an offset into a segment, linear address, or physical address. This depends on the error encountered. When these registers are implemented, these registers can be cleared by explicitly writing 0s to these registers. Writing 1s to these registers will cause a general-protection exception. See Figure 15-6.



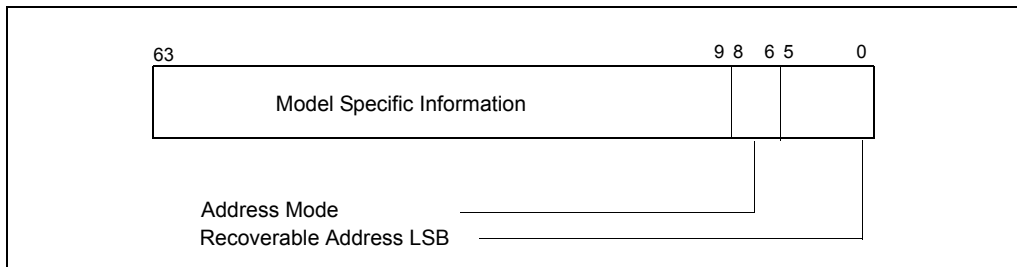
**Figure 15-6. IA32\_MCI\_ADDR MSR**

### 15.3.2.4 IA32\_MCi\_MISC MSRs

The IA32\_MCi\_MISC MSR contains additional information describing the machine-check error if the MISCV flag in the IA32\_MCi\_STATUS register is set. The IA32\_MCi\_MISC\_MSR is either not implemented or does not contain additional information if the MISCV flag in the IA32\_MCi\_STATUS register is clear.

When not implemented in the processor, all reads and writes to this MSR will cause a general protection exception. When implemented in a processor, these registers can be cleared by explicitly writing all 0s to them; writing 1s to them causes a general-protection exception to be generated. This register is not implemented in any of the error-reporting register banks for the P6 family processors.

If both MISCV and IA32\_MCG\_CAP[24] are set, the IA32\_MCi\_MISC\_MSR is defined according to Figure 15-7 to support software recovery of uncorrected errors (see Section 15.6):



**Figure 15-7. UCR Support in IA32\_MCi\_MISC Register**

- Recoverable Address LSB (bits 5:0): The lowest valid recoverable address bit. Indicates the position of the least significant bit (LSB) of the recoverable error address. For example, if the processor logs bits [43:9] of the address, the LSB sub-field in IA32\_MCi\_MISC is 01001b (9 decimal). For this example, bits [8:0] of the recoverable error address in IA32\_MCi\_ADDR should be ignored.
- Address Mode (bits 8:6): Address mode for the address logged in IA32\_MCi\_ADDR. The supported address modes are given in Table 15-3.

**Table 15-3. Address Mode in IA32\_MCi\_MISC[8:6]**

IA32_MCi_MISC[8:6] Encoding	Definition
000	Segment Offset
001	Linear Address
010	Physical Address
011	Memory Address

**Table 15-3. Address Mode in IA32\_MCi\_MISC[8:6]**

IA32_MCi_MISC[8:6] Encoding	Definition
100 to 110	Reserved
111	Generic

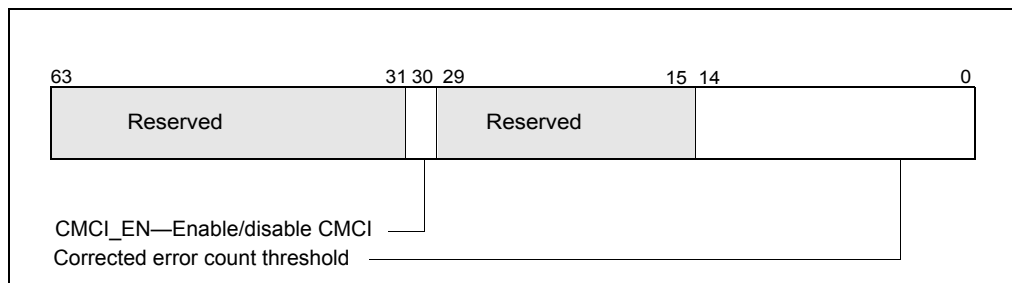
- Model Specific Information (bits 63:9): Not architecturally defined.

### 15.3.2.5 IA32\_MCi\_CTL2 MSRs

The IA32\_MCi\_CTL2 MSR provides the programming interface to use corrected MC error signaling capability that is indicated by IA32\_MCG\_CAP[10] = 1. Software must check for the presence of IA32\_MCi\_CTL2 on a per-bank basis.

When IA32\_MCG\_CAP[10] = 1, the IA32\_MCi\_CTL2 MSR for each bank exists, i.e. reads and writes to these MSR are supported. However, signaling interface for corrected MC errors may not be supported in all banks.

The layout of IA32\_MCi\_CTL2 is shown in Figure 15-8:



**Figure 15-8. IA32\_MCi\_CTL2 Register**

- **Corrected error count threshold, bits 14:0** — Software must initialize this field. The value is compared with the corrected error count field in IA32\_MCi\_STATUS, bits 38 through 52. An overflow event is signaled to the CMCI LVT entry (see Table 10-1) in the APIC when the count value equals the threshold value. The new LVT entry in the APIC is at 02F0H offset from the APIC\_BASE. If CMCI interface is not supported for a particular bank (but IA32\_MCG\_CAP[10] = 1), this field will always read 0.
- **CMCI\_EN—Corrected error interrupt enable/disable/indicator, bits 30** — Software sets this bit to enable the generation of corrected machine-check error interrupt (CMCI). If CMCI interface is not supported for a particular bank (but IA32\_MCG\_CAP[10] = 1), this bit is writeable but will always return 0 for that bank. This bit also indicates CMCI is supported or not supported in the corresponding bank. See Section 15.5 for details of software detection of CMCI facility.

Some microarchitectural sub-systems that are the source of corrected MC errors may be shared by more than one logical processors. Consequently, the facilities for reporting MC errors and controlling mechanisms may be shared by more than one logical processors. For example, the IA32\_MCi\_CTL2 MSR is shared between logical processors sharing a processor core. Software is responsible to program IA32\_MCi\_CTL2 MSR in a consistent manner with CMCI delivery and usage.

After processor reset, IA32\_MCi\_CTL2 MSRs are zero'ed.

### 15.3.2.6 IA32\_MCG Extended Machine Check State MSRs

The Pentium 4 and Intel Xeon processors implement a variable number of extended machine-check state MSRs. The MCG\_EXT\_P flag in the IA32\_MCG\_CAP MSR indicates the presence of these extended registers, and the MCG\_EXT\_CNT field indicates the number of these registers actually implemented. See Section 15.3.1.1, "IA32\_MCG\_CAP MSR." Also see Table 15-4.

**Table 15-4. Extended Machine Check State MSRs  
in Processors Without Support for Intel 64 Architecture**

MSR	Address	Description
IA32_MCG_EAX	180H	Contains state of the EAX register at the time of the machine-check error.
IA32_MCG_EBX	181H	Contains state of the EBX register at the time of the machine-check error.
IA32_MCG_ECX	182H	Contains state of the ECX register at the time of the machine-check error.
IA32_MCG_EDX	183H	Contains state of the EDX register at the time of the machine-check error.
IA32_MCG_ESI	184H	Contains state of the ESI register at the time of the machine-check error.
IA32_MCG_EDI	185H	Contains state of the EDI register at the time of the machine-check error.
IA32_MCG_EBP	186H	Contains state of the EBP register at the time of the machine-check error.
IA32_MCG_ESP	187H	Contains state of the ESP register at the time of the machine-check error.
IA32_MCG_EFLAGS	188H	Contains state of the EFLAGS register at the time of the machine-check error.
IA32_MCG_EIP	189H	Contains state of the EIP register at the time of the machine-check error.
IA32_MCG_MISC	18AH	When set, indicates that a page assist or page fault occurred during DS normal operation.

In processors with support for Intel 64 architecture, 64-bit machine check state MSRs are aliased to the legacy MSRs. In addition, there may be registers beyond IA32\_MCG\_MISC. These may include up to five reserved MSRs (IA32\_MCG\_RESERVED[1:5]) and save-state MSRs for registers introduced in 64-bit mode. See Table 15-5.

**Table 15-5. Extended Machine Check State MSRs  
In Processors With Support For Intel 64 Architecture**

MSR	Address	Description
IA32_MCG_RAX	180H	Contains state of the RAX register at the time of the machine-check error.
IA32_MCG_RBX	181H	Contains state of the RBX register at the time of the machine-check error.
IA32_MCG_RCX	182H	Contains state of the RCX register at the time of the machine-check error.
IA32_MCG_RDX	183H	Contains state of the RDX register at the time of the machine-check error.
IA32_MCG_RSI	184H	Contains state of the RSI register at the time of the machine-check error.
IA32_MCG_RDI	185H	Contains state of the RDI register at the time of the machine-check error.
IA32_MCG_RBP	186H	Contains state of the RBP register at the time of the machine-check error.
IA32_MCG_RSP	187H	Contains state of the RSP register at the time of the machine-check error.
IA32_MCG_RFLAGS	188H	Contains state of the RFLAGS register at the time of the machine-check error.
IA32_MCG_RIP	189H	Contains state of the RIP register at the time of the machine-check error.
IA32_MCG_MISC	18AH	When set, indicates that a page assist or page fault occurred during DS normal operation.
IA32_MCG_RESERVED[1:5]	18BH-18FH	These registers, if present, are reserved.
IA32_MCG_R8	190H	Contains state of the R8 register at the time of the machine-check error.
IA32_MCG_R9	191H	Contains state of the R9 register at the time of the machine-check error.
IA32_MCG_R10	192H	Contains state of the R10 register at the time of the machine-check error.

**Table 15-5. Extended Machine Check State MSRs  
In Processors With Support For Intel 64 Architecture (Contd.)**

MSR	Address	Description
IA32_MCG_R11	193H	Contains state of the R11 register at the time of the machine-check error.
IA32_MCG_R12	194H	Contains state of the R12 register at the time of the machine-check error.
IA32_MCG_R13	195H	Contains state of the R13 register at the time of the machine-check error.
IA32_MCG_R14	196H	Contains state of the R14 register at the time of the machine-check error.
IA32_MCG_R15	197H	Contains state of the R15 register at the time of the machine-check error.

When a machine-check error is detected on a Pentium 4 or Intel Xeon processor, the processor saves the state of the general-purpose registers, the R/EFLAGS register, and the R/EIP in these extended machine-check state MSRs. This information can be used by a debugger to analyze the error.

These registers are read/write to zero registers. This means software can read them; but if software writes to them, only all zeros is allowed. If software attempts to write a non-zero value into one of these registers, a general-protection (#GP) exception is generated. These registers are cleared on a hardware reset (power-up or RESET), but maintain their contents following a soft reset (INIT reset).

### 15.3.3 Mapping of the Pentium Processor Machine-Check Errors to the Machine-Check Architecture

The Pentium processor reports machine-check errors using two registers: P5\_MC\_TYPE and P5\_MC\_ADDR. The Pentium 4, Intel Xeon, and P6 family processors map these registers to the IA32\_MCi\_STATUS and IA32\_MCi\_ADDR in the error-reporting register bank. This bank reports on the same type of external bus errors reported in P5\_MC\_TYPE and P5\_MC\_ADDR.

The information in these registers can then be accessed in two ways:

- By reading the IA32\_MCi\_STATUS and IA32\_MCi\_ADDR registers as part of a general machine-check exception handler written for Pentium 4 and P6 family processors.
- By reading the P5\_MC\_TYPE and P5\_MC\_ADDR registers using the RDMSR instruction.

The second capability permits a machine-check exception handler written to run on a Pentium processor to be run on a Pentium 4, Intel Xeon, or P6 family processor. There is a limitation in that information returned by the Pentium 4, Intel Xeon, and P6 family processors is encoded differently than information returned by the Pentium



processor. To run a Pentium processor machine-check exception handler on a Pentium 4, Intel Xeon, or P6 family processor; the handler must be written to interpret P5\_MC\_TYPE encodings correctly.

### 15.4 ENHANCED CACHE ERROR REPORTING

Starting with Intel Core Duo processors, cache error reporting was enhanced. In earlier Intel processors, cache status was based on the number of correction events that occurred in a cache. In the new paradigm, called “threshold-based error status”, cache status is based on the number of lines (ECC blocks) in a cache that incur repeated corrections. The threshold is chosen by Intel, based on various factors. If a processor supports threshold-based error status, it sets IA32\_MCG\_CAP[11] (MCG\_TES\_P) to 1; if not, to 0.

A processor that supports enhanced cache error reporting contains hardware that tracks the operating status of certain caches and provides an indicator of their “health”. The hardware reports a “green” status when the number of lines that incur repeated corrections is at or below a pre-defined threshold, and a “yellow” status when the number of affected lines exceeds the threshold. Yellow status means that the cache reporting the event is operating correctly, but you should schedule the system for servicing within a few weeks.

Intel recommends that you rely on this mechanism for structures supported by threshold-base error reporting.

The CPU/system/platform response to a yellow event should be less severe than its response to an uncorrected error. An uncorrected error means that a serious error has actually occurred, whereas the yellow condition is a warning that the number of affected lines has exceeded the threshold but is not, in itself, a serious event: the error was corrected and system state was not compromised.

The green/yellow status indicator is not a foolproof early warning for an uncorrected error resulting from the failure of two bits in the same ECC block. Such a failure can occur and cause an uncorrected error before the yellow threshold is reached. However, the chance of an uncorrected error increases as the number of affected lines increases.

### 15.5 CORRECTED MACHINE CHECK ERROR INTERRUPT

Corrected machine-check error interrupt (CMCI) is an architectural enhancement to the machine-check architecture. It provides capabilities beyond those of threshold-based error reporting (Section 15.4). With threshold-based error reporting, software is limited to use periodic polling to query the status of hardware corrected MC errors. CMCI provides a signaling mechanism to deliver a local interrupt based on threshold values that software can program using the IA32\_MCi\_CTL2 MSRs.

CMCI is disabled by default. System software is required to enable CMCI for each IA32\_MCi bank that support the reporting of hardware corrected errors if  $IA32\_MCG\_CAP[10] = 1$ .

System software use IA32\_MCi\_CTL2 MSR to enable/disable the CMCI capability for each bank and program threshold values into IA32\_MCi\_CTL2 MSR. CMCI is not affected by the CR4.MCE bit, and it is not affected by the IA32\_MCi\_CTL MSR's.

To detect the existence of thresholding for a given bank, software writes only bits 14:0 with the threshold value. If the bits persist, then thresholding is available (and CMCI is available). If the bits are all 0's, then no thresholding exists. To detect that CMCI signaling exists, software writes a 1 to bit 30 of the MCI\_CTL2 register. Upon subsequent read, If Bit 30 = 0, no CMCI is available for this bank. If Bit 30 = 1, then CMCI is available and enabled.

## 15.5.1 CMCI Local APIC Interface

The operation of CMCI is depicted in Figure 15-9.

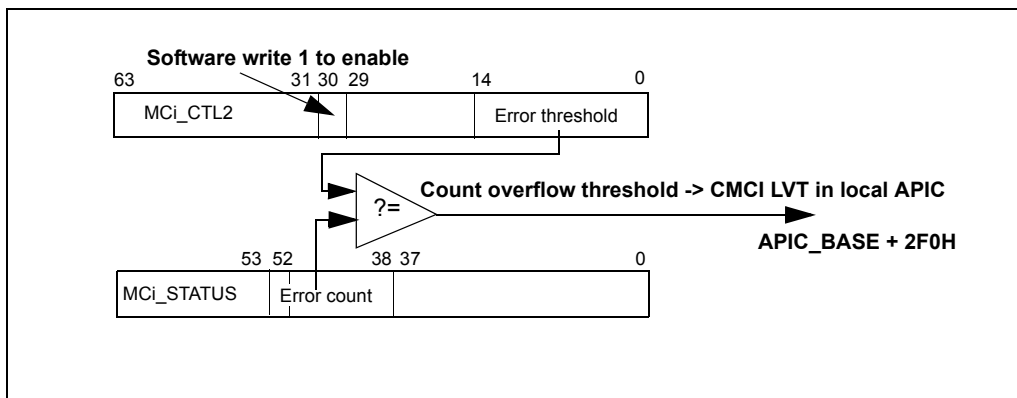


Figure 15-9. CMCI Behavior

CMCI interrupt delivery is configured by writing to the LVT CMCI register entry in the local APIC register space at default address of  $APIC\_BASE + 2F0H$ . A CMCI interrupt can be delivered to more than one logical processors if multiple logical processors are affected by the associated MC errors. For example, if a corrected bit error in a cache shared by two logical processors caused a CMCI, the interrupt will be delivered to both logical processors sharing that microarchitectural sub-system. Similarly, package level errors may cause CMCI to be delivered to all logical processors within the package. However, system level errors will not be handled by CMCI.

See Section 10.5.1, "Local Vector Table" for details regarding the LVT CMCI register.

## 15.5.2 System Software Recommendation for Managing CMCI and Machine Check Resources

System software must enable and manage CMCI, set up interrupt handlers to service CMCI interrupts delivered to affected logical processors, program CMCI LVT entry, and query machine check banks that are shared by more than one logical processors.

This section describes techniques system software can implement to manage CMCI initialization, service CMCI interrupts in a efficient manner to minimize contentions to access shared MSR resources.

### 15.5.2.1 CMCI Initialization

Although a CMCI interrupt may be delivered to more than one logical processors depending on the nature of the corrected MC error, only one instance of the interrupt service routine needs to perform the necessary service and make queries to the machine-check banks. The following steps describes a technique that limits the amount of work the system has to do in response to a CMCI.

- To provide maximum flexibility, system software should define per-thread data structure for each logical processor to allow equal-opportunity and efficient response to interrupt delivery. Specifically, the per-thread data structure should include a set of per-bank fields to track which machine check bank it needs to access in response to a delivered CMCI interrupt. The number of banks that needs to be tracked is determined by `IA32_MCG_CAP[7:0]`.
- Initialization of per-thread data structure. The initialization of per-thread data structure must be done serially on each logical processor in the system. The sequencing order to start the per-thread initialization between different logical processor is arbitrary. But it must observe the following specific detail to satisfy the shared nature of specific MSR resources:
  - a. Each thread initializes its data structure to indicate that it does not own any MC bank registers.
  - b. Each thread examines `IA32_MCi_CTL2[30]` indicator for each bank to determine if another thread has already claimed ownership of that bank.
    - If `IA32_MCi_CTL2[30]` had been set by another thread. This thread can not own bank *i* and should proceed to step b. and examine the next machine check bank until all of the machine check banks are exhausted.
    - If `IA32_MCi_CTL2[30] = 0`, proceed to step c.
  - c. Check whether writing a 1 into `IA32_MCi_CTL2[30]` can return with 1 on a subsequent read to determine this bank can support CMCI.
    - If `IA32_MCi_CTL2[30] = 0`, this bank does not support CMCI. This thread can not own bank *i* and should proceed to step b. and examine the next machine check bank until all of the machine check banks are exhausted.
    - If `IA32_MCi_CTL2[30] = 1`, modify the per-thread data structure to indicate this thread claims ownership to the MC bank; proceed to initialize

the error threshold count (bits 15:0) of that bank as described in Chapter 15, “CMCI Threshold Management”. Then proceed to step b. and examine the next machine check bank until all of the machine check banks are exhausted.

- After the thread has examined all of the machine check banks, it sees if it owns any MC banks to service CMCI. If any bank has been claimed by this thread:
  - Ensure that the CMCI interrupt handler has been set up as described in Chapter 15, “CMCI Interrupt Handler”.
  - Initialize the CMCI LVT entry, as described in Section 15.5.1, “CMCI Local APIC Interface”.
  - Log and clear all of IA32\_MCi\_Status registers for the banks that this thread owns. This will allow new errors to be logged.

### 15.5.2.2 CMCI Threshold Management

The Corrected MC error threshold field, IA32\_MCi\_CTL2[15:0], is architecturally defined. Specifically, all these bits are writable by software, but different processor implementations may choose to implement less than 15 bits as threshold for the overflow comparison with IA32\_MCi\_STATUS[52:38]. The following describes techniques that software can manage CMCI threshold to be compatible with changes in implementation characteristics:

- Software can set the initial threshold value to 1 by writing 1 to IA32\_MCi\_CTL2[15:0]. This will cause overflow condition on every corrected MC error and generates a CMCI interrupt.
- To increase the threshold and reduce the frequency of CMCI servicing:
  - a. Find the maximum threshold value a given processor implementation supports. The steps are:
    - Write 7FFFH to IA32\_MCi\_CTL2[15:0],
    - Read back IA32\_MCi\_CTL2[15:0], the lower 15 bits (14:0) is the maximum threshold supported by the processor.
  - b. Increase the threshold to a value below the maximum value discovered using step a.

### 15.5.2.3 CMCI Interrupt Handler

The following describes techniques system software may consider to implement a CMCI service routine:

- The service routine examines its private per-thread data structure to check which set of MC banks it has ownership. If the thread does not have ownership of a given MC bank, proceed to the next MC bank. Ownership is determined at initialization time which is described in Section [Cross Reference to 14.5.2.1].
- If the thread had claimed ownership to an MC bank,

- Check for valid MC errors by testing `IA32_MCi_STATUS.VALID[63]`,
  - Log MC errors,
  - Clear the MSRs of this MC bank.
- If no valid error, proceed to next MC bank.
- When all MC banks have been processed, exit service routine and return to original program execution.

This technique will allow each logical processors to handle corrected MC errors independently and requires no synchronization to access shared MSR resources.

## 15.6 RECOVERY OF UNCORRECTED RECOVERABLE (UCR) ERRORS

Recovery of uncorrected recoverable machine check errors is an enhancement in machine-check architecture. The first processor that supports this feature is 45nm Intel 64 processor on which `CPUID` reports `DisplayFamily_DisplayModel` as `06H_2EH` (see `CPUID` instruction in Chapter 3, “Instruction Set Reference, A-L” in the *Intel® 64 and IA-32 Architectures Software Developer’s Manual, Volume 2A*). This allow system software to perform recovery action on certain class of uncorrected errors and continue execution.

### 15.6.1 Detection of Software Error Recovery Support

Software must use bit 24 of `IA32_MCG_CAP` (`MCG_SER_P`) to detect the presence of software error recovery support (see Figure 15-2). When `IA32_MCG_CAP[24]` is set, this indicates that the processor supports software error recovery. When this bit is clear, this indicates that there is no support for error recovery from the processor and the primary responsibility of the machine check handler is logging the machine check error information and shutting down the system.

The new class of architectural MCA errors from which system software can attempt recovery is called Uncorrected Recoverable (UCR) Errors. UCR errors are uncorrected errors that have been detected and signaled but have not corrupted the processor context. For certain UCR errors, this means that once system software has performed a certain recovery action, it is possible to continue execution on this processor. UCR error reporting provides an error containment mechanism for data poisoning. The machine check handler will use the error log information from the error reporting registers to analyze and implement specific error recovery actions for UCR errors.

## 15.6.2 UCR Error Reporting and Logging

IA32\_MCi\_STATUS MSR is used for reporting UCR errors and existing corrected or uncorrected errors. The definitions of IA32\_MCi\_STATUS, including bit fields to identify UCR errors, is shown in Figure 15-5. UCR errors can be signaled through either the corrected machine check interrupt (CMCI) or machine check exception (MCE) path depending on the type of the UCR error.

When IA32\_MCG\_CAP[24] is set, a UCR error is indicated by the following bit settings in the IA32\_MCi\_STATUS register:

- Valid (bit 63) = 1
- UC (bit 61) = 1
- PCC (bit 57) = 0

Additional information from the IA32\_MCi\_MISC and the IA32\_MCi\_ADDR registers for the UCR error are available when the ADDR\_V and the MISC\_V flags in the IA32\_MCi\_STATUS register are set (see Section 15.3.2.4). The MCA error code field of the IA32\_MCi\_STATUS register indicates the type of UCR error. System software can interpret the MCA error code field to analyze and identify the necessary recovery action for the given UCR error.

In addition, the IA32\_MCi\_STATUS register bit fields, bits 56:55, are defined (see Figure 15-5) to provide additional information to help system software to properly identify the necessary recovery action for the UCR error:

- S (Signaling) flag, bit 56 - Indicates (when set) that a machine check exception was generated for the UCR error reported in this MC bank and system software needs to check the AR flag and the MCA error code fields in the IA32\_MCi\_STATUS register to identify the necessary recovery action for this error. When the S flag in the IA32\_MCi\_STATUS register is clear, this UCR error was not signaled via a machine check exception and instead was reported as a corrected machine check (CMC). System software is not required to take any recovery action when the S flag in the IA32\_MCi\_STATUS register is clear.
- AR (Action Required) flag, bit 55 - Indicates (when set) that MCA error code specific recovery action must be performed by system software at the time this error was signaled. This recovery action must be completed successfully before any additional work is scheduled for this processor. When the RIP\_V flag in the IA32\_MCG\_STATUS is clear, an alternative execution stream needs to be provided; when the MCA error code specific recovery specific recovery action cannot be successfully completed, system software must shut down the system. When the AR flag in the IA32\_MCi\_STATUS register is clear, system software may still take MCA error code specific recovery action but this is optional; system software can safely resume program execution at the instruction pointer saved on the stack from the machine check exception when the RIP\_V flag in the IA32\_MCG\_STATUS register is set.

Both the S and the AR flags in the IA32\_MCi\_STATUS register are defined to be sticky bits, which mean that once set, the processor does not clear them. Only software and

good power-on reset can clear the S and the AR-flags. Both the S and the AR flags are only set when the processor reports the UCR errors (MCG\_CAP[24] is set).

### 15.6.3 UCR Error Classification

With the S and AR flag encoding in the IA32\_MCi\_STATUS register, UCR errors can be classified as:

- **Uncorrected no action required (UCNA)** - is a UCR error that is not signaled via a machine check exception and, instead, is reported to system software as a corrected machine check error. UCNA errors indicate that some data in the system is corrupted, but the data has not been consumed and the processor state is valid and you may continue execution on this processor. UCNA errors require no action from system software to continue execution. A UCNA error is indicated with UC=1, PCC=0, S=0 and AR=0 in the IA32\_MCi\_STATUS register.
- **Software recoverable action optional (SRAO)** - a UCR error is signaled via a machine check exception and a system software recovery action is optional and not required to continue execution from this machine check exception. SRAO errors indicate that some data in the system is corrupt, but the data has not been consumed and the processor state is valid. SRAO errors provide the additional error information for system software to perform a recovery action. An SRAO error is indicated with UC=1, PCC=0, S=1, EN=1 and AR=0 in the IA32\_MCi\_STATUS register. Recovery actions for SRAO errors are MCA error code specific. The MISCV and the ADDRv flags in the IA32\_MCi\_STATUS register are set when the additional error information is available from the IA32\_MCi\_MISC and the IA32\_MCi\_ADDR registers. System software needs to inspect the MCA error code fields in the IA32\_MCi\_STATUS register to identify the specific recovery action for a given SRAO error. If MISCV and ADDRv are not set, it is recommended that no system software error recovery be performed however, you can resume execution.
- **Software recoverable action required (SRAR)** - a UCR error that requires system software to take a recovery action on this processor before scheduling another stream of execution on this processor. SRAR errors indicate that the error was detected and raised at the point of the consumption in the execution flow. An SRAR error is indicated with UC=1, PCC=0, S=1, EN=1 and AR=1 in the IA32\_MCi\_STATUS register. Recovery actions are MCA error code specific. The MISCV and the ADDRv flags in the IA32\_MCi\_STATUS register are set when the additional error information is available from the IA32\_MCi\_MISC and the IA32\_MCi\_ADDR registers. System software needs to inspect the MCA error code fields in the IA32\_MCi\_STATUS register to identify the specific recovery action for a given SRAR error. If MISCV and ADDRv are not set, it is recommended that system software shutdown the system.

Table 15-6 summarizes UCR, corrected, and uncorrected errors.

**Table 15-6. MC Error Classifications**

Type of Error <sup>1</sup>	UC	PCC	S	AR	Signaling	Software Action	Example
Uncorrected Error (UC)	1	1	x	x	MCE	Reset the system	
SRAR	1	0	1	1	MCE	For known MCACOD, take specific recovery action; For unknown MCACOD, must bugcheck	Cache to processor load error
SRAO	1	0	1	0	MCE	For known MCACOD, take specific recovery action; For unknown MCACOD, OK to keep the system running	Patrol scrub and explicit writeback poison errors
UCNA	1	0	0	0	CMC	Log the error and Ok to keep the system running	Poison detection error
Corrected Error (CE)	0	0	x	x	CMC	Log the error and no corrective action required	ECC in caches and memory

**NOTES:**

1. VAL=1, EN=1 for UC=1 errors; OVER=0 for UC=1 and PCC=0 errors SRAR, SRAO and UCNA errors are supported by the processor only when IA32\_MCG\_CAP[24] (MCG\_SER\_P) is set.

## 15.6.4 UCR Error Overwrite Rules

In general, the overwrite rules are as follows:

- UCR errors will overwrite corrected errors.
- Uncorrected (PCC=1) errors overwrite UCR (PCC=0) errors.
- UCR errors are not written over previous UCR errors.
- Corrected errors do not write over previous UCR errors.

Regardless of whether the 1st error is retained or the 2nd error is overwritten over the 1st error, the OVER flag in the IA32\_MCi\_STATUS register will be set to indicate an overflow condition. As the S flag and AR flag in the IA32\_MCi\_STATUS register are defined to be sticky flags, a second event cannot clear these 2 flags once set, however the MC bank information may be filled in for the 2nd error. The table below shows the overwrite rules and how to treat a second error if the first event is already logged in a MC bank along with the resulting bit setting of the UC, PCC, and AR flags in the IA32\_MCi\_STATUS register. As UCNA and SRAO errors do not require recovery action from system software to continue program execution, a system reset by



system software is not required unless the AR flag or PCC flag is set for the UCR overflow case (OVER=1, VAL=1, UC=1, PCC=0).

Table 15-7 lists overwrite rules for uncorrected errors, corrected errors, and uncorrected recoverable errors.

**Table 15-7. Overwrite Rules for UC, CE, and UCR Errors**

First Event	Second Event	UC	PCC	S	AR	MCA Bank	Reset System
CE	UCR	1	0	0 if UCNA, else 1	1 if SRAR, else 0	second	yes, if AR=1
UCR	CE	1	0	0 if UCNA, else 1	1 if SRAR, else 0	first	yes, if AR=1
UCNA	UCNA	1	0	0	0	first	no
UCNA	SRAO	1	0	1	0	first	no
UCNA	SRAR	1	0	1	1	first	yes
SRAO	UCNA	1	0	1	0	first	no
SRAO	SRAO	1	0	1	0	first	no
SRAO	SRAR	1	0	1	1	first	yes
SRAR	UCNA	1	0	1	1	first	yes
SRAR	SRAO	1	0	1	1	first	yes
SRAR	SRAR	1	0	1	1	first	yes
UCR	UC	1	1	undefined	undefined	second	yes
UC	UCR	1	1	undefined	undefined	first	yes

## 15.7 MACHINE-CHECK AVAILABILITY

The machine-check architecture and machine-check exception (#MC) are model-specific features. Software can execute the CPUID instruction to determine whether a processor implements these features. Following the execution of the CPUID instruction, the settings of the MCA flag (bit 14) and MCE flag (bit 7) in EDX indicate whether the processor implements the machine-check architecture and machine-check exception.

## 15.8 MACHINE-CHECK INITIALIZATION

To use the processors machine-check architecture, software must initialize the processor to activate the machine-check exception and the error-reporting mechanism.

Example 15-1 gives pseudocode for performing this initialization. This pseudocode checks for the existence of the machine-check architecture and exception; it then

enables machine-check exception and the error-reporting register banks. The pseudocode shown is compatible with the Pentium 4, Intel Xeon, P6 family, and Pentium processors.

Following power up or power cycling, IA32\_MCi\_STATUS registers are not guaranteed to have valid data until after they are initially cleared to zero by software (as shown in the initialization pseudocode in Example 15-1). In addition, when using P6 family processors, software must set MCI\_STATUS registers to zero when doing a soft-reset.

### Example 15-1. Machine-Check Initialization Pseudocode

Check CPUID Feature Flags for MCE and MCA support

IF CPU supports MCE

THEN

IF CPU supports MCA

THEN

IF (IA32\_MCG\_CAP.MCG\_CTL\_P = 1)

(\* IA32\_MCG\_CTL register is present \*)

THEN

IA32\_MCG\_CTL ← FFFFFFFFFFFFFFFFH;

(\* enables all MCA features \*)

FI

(\* Determine number of error-reporting banks supported \*)

COUNT ← IA32\_MCG\_CAP.Count;

MAX\_BANK\_NUMBER ← COUNT - 1;

IF (Processor Family is 6H and Processor EXTMODEL.MODEL is less than 1AH)

THEN

(\* Enable logging of all errors except for MCO\_CTL register \*)

FOR error-reporting banks (1 through MAX\_BANK\_NUMBER)

DO

IA32\_MCi\_CTL ← OFFFFFFFFFFFFFFFH;

OD

ELSE

(\* Enable logging of all errors including MCO\_CTL register \*)

FOR error-reporting banks (0 through MAX\_BANK\_NUMBER)

DO

IA32\_MCi\_CTL ← OFFFFFFFFFFFFFFFH;

OD

FI

(\* BIOS clears all errors only on power-on reset \*)

IF (BIOS detects Power-on reset)

THEN

FOR error-reporting banks (0 through MAX\_BANK\_NUMBER)

DO

IA32\_MCi\_STATUS ← 0;

OD

ELSE

```

FOR error-reporting banks (0 through MAX_BANK_NUMBER)
DO
  (Optional for BIOS and OS) Log valid errors
  (OS only) IA32_MCi_STATUS ← 0;
OD

```

FI  
FI

Setup the Machine Check Exception (#MC) handler for vector 18 in IDT

Set the MCE bit (bit 6) in CR4 register to enable Machine-Check Exceptions

FI

## 15.9 INTERPRETING THE MCA ERROR CODES

When the processor detects a machine-check error condition, it writes a 16-bit error code to the MCA error code field of one of the IA32\_MCi\_STATUS registers and sets the VAL (valid) flag in that register. The processor may also write a 16-bit model-specific error code in the IA32\_MCi\_STATUS register depending on the implementation of the machine-check architecture of the processor.

The MCA error codes are architecturally defined for Intel 64 and IA-32 processors. To determine the cause of a machine-check exception, the machine-check exception handler must read the VAL flag for each IA32\_MCi\_STATUS register. If the flag is set, the machine check-exception handler must then read the MCA error code field of the register. It is the encoding of the MCA error code field [15:0] that determines the type of error being reported and not the register bank reporting it.

There are two types of MCA error codes: simple error codes and compound error codes.

### 15.9.1 Simple Error Codes

Table 15-8 shows the simple error codes. These unique codes indicate global error information.

**Table 15-8. IA32\_MCi\_Status [15:0] Simple Error Code Encoding**

Error Code	Binary Encoding	Meaning
No Error	0000 0000 0000 0000	No error has been reported to this bank of error-reporting registers.
Unclassified	0000 0000 0000 0001	This error has not been classified into the MCA error classes.
Microcode ROM Parity Error	0000 0000 0000 0010	Parity error in internal microcode ROM

**Table 15-8. IA32\_MCi\_Status [15:0] Simple Error Code Encoding (Contd.)**

External Error	0000 0000 0000 0011	The BINIT# from another processor caused this processor to enter machine check. <sup>1</sup>
FRC Error	0000 0000 0000 0100	FRC (functional redundancy check) master/slave error
Internal Parity Error	0000 0000 0000 0101	Internal parity error.
Internal Timer Error	0000 0100 0000 0000	Internal timer error.
Internal Unclassified	0000 01xx xxxx xxxx	Internal unclassified errors. <sup>2</sup>

**NOTES:**

1. BINIT# assertion will cause a machine check exception if the processor (or any processor on the same external bus) has BINIT# observation enabled during power-on configuration (hardware strapping) and if machine check exceptions are enabled (by setting CR4.MCE = 1).
2. At least one X must equal one. Internal unclassified errors have not been classified.

## 15.9.2 Compound Error Codes

Compound error codes describe errors related to the TLBs, memory, caches, bus and interconnect logic, and internal timer. A set of sub-fields is common to all of compound errors. These sub-fields describe the type of access, level in the cache hierarchy, and type of request. Table 15-9 shows the general form of the compound error codes.

**Table 15-9. IA32\_MCi\_Status [15:0] Compound Error Code Encoding**

Type	Form	Interpretation
Generic Cache Hierarchy	000F 0000 0000 11LL	Generic cache hierarchy error
TLB Errors	000F 0000 0001 TTLL	{TT}TLB{LL}_ERR
Memory Controller Errors	000F 0000 1MMM CCCC	{MMM}_CHANNEL{CCCC}_ERR
Cache Hierarchy Errors	000F 0001 RRRR TTLL	{TT}CACHE{LL}_{RRRR}_ERR
Bus and Interconnect Errors	000F 1PPT RRRR IILL	BUS{LL}_{PP}_{RRRR}_{II}_{T}_ERR

The “Interpretation” column in the table indicates the name of a compound error. The name is constructed by substituting mnemonics for the sub-field names given within curly braces. For example, the error code ICACHEL1\_RD\_ERR is constructed from the form:

{TT}CACHE{LL}\_{RRRR}\_ERR,  
 where {TT} is replaced by I, {LL} is replaced by L1, and {RRRR} is replaced by RD.

For more information on the “Form” and “Interpretation” columns, see Sections Section 15.9.2.1, “Correction Report Filtering (F) Bit” through Section 15.9.2.5, “Bus and Interconnect Errors”.

### 15.9.2.1 Correction Report Filtering (F) Bit

Starting with Intel Core Duo processors, bit 12 in the “Form” column in Table 15-9 is used to indicate that a particular posting to a log may be the last posting for corrections in that line/entry, at least for some time:

- 0 in bit 12 indicates “normal” filtering (original P6/Pentium4/Xeon processor meaning).
- 1 in bit 12 indicates “corrected” filtering (filtering is activated for the line/entry in the posting). Filtering means that some or all of the subsequent corrections to this entry (in this structure) will not be posted. The enhanced error reporting introduced with the Intel Core Duo processors is based on tracking the lines affected by repeated corrections (see Section 15.4, “Enhanced Cache Error reporting”). This capability is indicated by IA32\_MCG\_CAP[11]. Only the first few correction events for a line are posted; subsequent redundant correction events to the same line are not posted. Uncorrected events are always posted.

The behavior of error filtering after crossing the yellow threshold is model-specific.

### 15.9.2.2 Transaction Type (TT) Sub-Field

The 2-bit TT sub-field (Table 15-10) indicates the type of transaction (data, instruction, or generic). The sub-field applies to the TLB, cache, and interconnect error conditions. Note that interconnect error conditions are primarily associated with P6 family and Pentium processors, which utilize an external APIC bus separate from the system bus. The generic type is reported when the processor cannot determine the transaction type.

**Table 15-10. Encoding for TT (Transaction Type) Sub-Field**

Transaction Type	Mnemonic	Binary Encoding
Instruction	I	00
Data	D	01
Generic	G	10

### 15.9.2.3 Level (LL) Sub-Field

The 2-bit LL sub-field (see Table 15-11) indicates the level in the memory hierarchy where the error occurred (level 0, level 1, level 2, or generic). The LL sub-field also applies to the TLB, cache, and interconnect error conditions. The Pentium 4, Intel Xeon, and P6 family processors support two levels in the cache hierarchy and one level in the TLBs. Again, the generic type is reported when the processor cannot determine the hierarchy level.

**Table 15-11. Level Encoding for LL (Memory Hierarchy Level) Sub-Field**

Hierarchy Level	Mnemonic	Binary Encoding
Level 0	L0	00

**Table 15-11. Level Encoding for LL (Memory Hierarchy Level) Sub-Field (Contd.)**

Level 1	L1	01
Level 2	L2	10
Generic	LG	11

### 15.9.2.4 Request (RRRR) Sub-Field

The 4-bit RRRR sub-field (see Table 15-12) indicates the type of action associated with the error. Actions include read and write operations, prefetches, cache evictions, and snoops. Generic error is returned when the type of error cannot be determined. Generic read and generic write are returned when the processor cannot determine the type of instruction or data request that caused the error. Eviction and snoop requests apply only to the caches. All of the other requests apply to TLBs, caches and interconnects.

**Table 15-12. Encoding of Request (RRRR) Sub-Field**

Request Type	Mnemonic	Binary Encoding
Generic Error	ERR	0000
Generic Read	RD	0001
Generic Write	WR	0010
Data Read	DRD	0011
Data Write	DWR	0100
Instruction Fetch	IRD	0101
Prefetch	PREFETCH	0110
Eviction	EVICT	0111
Snoop	SNOOP	1000

### 15.9.2.5 Bus and Interconnect Errors

The bus and interconnect errors are defined with the 2-bit PP (participation), 1-bit T (time-out), and 2-bit II (memory or I/O) sub-fields, in addition to the LL and RRRR sub-fields (see Table 15-13). The bus error conditions are implementation dependent and related to the type of bus implemented by the processor. Likewise, the interconnect error conditions are predicated on a specific implementation-dependent interconnect model that describes the connections between the different levels of the storage hierarchy. The type of bus is implementation dependent, and as such is not specified in this document. A bus or interconnect transaction consists of a request involving an address and a response.

**Table 15-13. Encodings of PP, T, and II Sub-Fields**

Sub-Field	Transaction	Mnemonic	Binary Encoding
-----------	-------------	----------	-----------------

**Table 15-13. Encodings of PP, T, and II Sub-Fields (Contd.)**

PP (Participation)	Local processor* originated request	SRC	00
	Local processor* responded to request	RES	01
	Local processor* observed error as third party	OBS	10
	Generic		11
T (Time-out)	Request timed out	TIMEOUT	1
	Request did not time out	NOTIMEOUT	0
II (Memory or I/O)	Memory Access	M	00
	Reserved		01
	I/O	IO	10
	Other transaction		11

**NOTE:**

\* Local processor differentiates the processor reporting the error from other system components (including the APIC, other processors, etc.).

### 15.9.2.6 Memory Controller Errors

The memory controller errors are defined with the 3-bit MMM (memory transaction type), and 4-bit CCCC (channel) sub-fields. The encodings for MMM and CCCC are defined in Table 15-14.

**Table 15-14. Encodings of MMM and CCCC Sub-Fields**

Sub-Field	Transaction	Mnemonic	Binary Encoding
MMM	Generic undefined request	GEN	000
	Memory read error	RD	001
	Memory write error	WR	010
	Address/Command Error	AC	011
	Memory Scrubbing Error	MS	100
	Reserved		101-111
CCCC	Channel number	CHN	0000-1110
	Channel not specified		1111

### 15.9.3 Architecturally Defined UCR Errors

Software recoverable compound error code are defined in this section.

### 15.9.3.1 Architecturally Defined SRAO Errors

The following two SRAO errors are architecturally defined.

- UCR Errors detected by memory controller scrubbing; and
- UCR Errors detected during L3 cache (L3) explicit writebacks.

The MCA error code encodings for these two architecturally-defined UCR errors corresponds to sub-classes of compound MCA error codes (see Table 15-9). Their values and compound encoding format are given in Table 15-15.

**Table 15-15. MCA Compound Error Code Encoding for SRAO Errors**

Type	MCACOD Value	MCA Error Code Encoding <sup>1</sup>
Memory Scrubbing	0xC0 - 0xCF	0000_0000_1100_CCCC 000F 0000 1MMM CCCC (Memory Controller Error), where Memory subfield MMM = 100B (memory scrubbing) Channel subfield CCCC = channel # or generic
L3 Explicit Writeback	0x17A	0000_0001_0111_1010 000F 0001 RRRR TTLL (Cache Hierarchy Error) where Request subfields RRRR = 0111B (Eviction) Transaction Type subfields TT = 10B (Generic) Level subfields LL = 10B

#### NOTES:

1. Note that for both of these errors the correction report filtering (F) bit (bit 12) of the MCA error is 0, indicating "normal" filtering.

Table 15-16 lists values of relevant bit fields of IA32\_MCi\_STATUS for architecturally defined SRAO errors.

**Table 15-16. IA32\_MCi\_STATUS Values for SRAO Errors**

SRAO Error	Valid	OVER	UC	EN	MISCV	ADDRV	PCC	S	AR	MCACOD
Memory Scrubbing	1	0	1	1	1	1	0	1	0	0xC0-0xCF
L3 Explicit Writeback	1	0	1	1	1	1	0	1	0	0x17A

For both the memory scrubbing and L3 explicit writeback errors, the ADDRv and MISCV flags in the IA32\_MCi\_STATUS register are set to indicate that the offending physical address information is available from the IA32\_MCi\_MISC and the IA32\_MCi\_ADDR registers. For the memory scrubbing and L3 explicit writeback errors, the address mode in the IA32\_MCi\_MISC register should be set as physical address mode (010b) and the address LSB information in the IA32\_MCi\_MISC register should indicate the lowest valid address bit in the address information provided from the IA32\_MCi\_ADDR register.

An MCE signal is broadcast to all logical processors on the system on which the UCR errors are supported. MCI\_STATUS banks can be shared by logical processors within



a core or within the same package. So several logical processors may find an SRAO error in the shared IA32\_MCi\_STATUS bank but other processors do not find it in any of the IA32\_MCi\_STATUS banks. Table 15-17 shows the RIPV and EIPV flag indication in the IA32\_MCG\_STATUS register for the memory scrubbing and L3 explicit write-back errors on both the reporting and non-reporting logical processors.

**Table 15-17. IA32\_MCG\_STATUS Flag Indication for SRAO Errors**

SRAO Type	Reporting Logical Processors		Non-reporting Logical Processors	
	RIPV	EIPV	RIPV	EIPV
Memory Scrubbing	1	0	1	0
L3 Explicit Writeback	1	0	1	0

### 15.9.3.2 Architecturally Defined SRAR Errors

The following two SRAR errors are architecturally defined.

- UCR Errors detected on data load; and
- UCR Errors detected on instruction fetch.

The MCA error code encodings for these two architecturally-defined UCR errors corresponds to sub-classes of compound MCA error codes (see Table 15-9). Their values and compound encoding format are given in Table 15-18.

**Table 15-18. MCA Compound Error Code Encoding for SRAR Errors**

Type	MCACOD Value	MCA Error Code Encoding <sup>1</sup>
Data Load	0x134	0000_0001_0011_0100 000F 0001 RRRR TTLL (Cache Hierarchy Error), where Request subfield RRRR = 0011B (Data Load) Transaction Type subfield TT= 01B (Data) Level subfield LL = 00B (Level 0)
Instruction Fetch	0x150	0000_0001_0101_0000 000F 0001 RRRR TTLL (Cache Hierarchy Error), where Request subfield RRRR = 0101B (Instruction Fetch) Transaction Type subfield TT= 00B (Instruction) Level subfield LL = 00B (Level 0)

**NOTES:**

1. Note that for both of these errors the correction report filtering (F) bit (bit 12) of the MCA error is 0, indicating "normal" filtering.

Table 15-19 lists values of relevant bit fields of IA32\_MCi\_STATUS for architecturally defined SRAR errors.

**Table 15-19. IA32\_MCi\_STATUS Values for SRAR Errors**

SRAR Error	Valid	OVER	UC	EN	MISCV	ADDRV	PCC	S	AR	MCACOD
Data Load	1	0	1	1	1	1	0	1	1	0x134
Instruction Fetch	1	0	1	1	1	1	0	1	1	0x150

For both the data load and instruction fetch errors, the ADDRv and MISCV flags in the IA32\_MCi\_STATUS register are set to indicate that the offending physical address information is available from the IA32\_MCi\_MISC and the IA32\_MCi\_ADDR registers. For the memory scrubbing and L3 explicit writeback errors, the address mode in the IA32\_MCi\_MISC register should be set as physical address mode (010b) and the address LSB information in the IA32\_MCi\_MISC register should indicate the lowest valid address bit in the address information provided from the IA32\_MCi\_ADDR register.

An MCE signal is broadcast to all logical processors on the system on which the UCR errors are supported. The IA32\_MCG\_STATUS MSR allows system software to distinguish the affected logical processor of an SRAR error amongst logical processors that observed SRAR via a shared MCi\_STATUS bank.

Table 15-20 shows the RIPV and EIPV flag indication in the IA32\_MCG\_STATUS register for the data load and instruction fetch errors on both the reporting and non-reporting logical processors.

**Table 15-20. IA32\_MCG\_STATUS Flag Indication for SRAR Errors**

SRAR Type	Affected Logical Processors		Non-Affected Logical Processors	
	RIPV	EIPV	RIPV	EIPV
Data Load	0	1	1	0
Instruction Fetch	0	0	1	0

The affected logical processor is the one that has detected and raised an SRAR error at the point of the consumption in the execution flow. The affected logical processor should find the Data Load or the Instruction Fetch error information in the IA32\_MCi\_STATUS register that is reporting the SRAR error.

For Data Load recoverable errors, the affected logical processor should find that the IA32\_MCG\_STATUS.RIPV flag is cleared and the IA32\_MCG\_STATUS.EIPV flag is set indicating that the error is detected at the instruction pointer saved on the stack for this machine check exception and restarting execution with the interrupted context is not possible.

For Instruction Fetch recoverable error, the affected logical processor should find that the RIPV flag and the EIPV Flag in the IA32\_MCG\_STATUS register are cleared, indicating that the error is detected at the instruction pointer saved on the stack may not be associated with this error and restarting the execution with the interrupted context is not possible.

The logical processors that observed but not affected by an SRAR error should find that the RIPV flag in the IA32\_MCG\_STATUS register is set and the EIPV flag in the IA32\_MCG\_STATUS register is cleared, indicating that it is safe to restart the execution at the instruction saved on the stack for the machine check exception on these processors after the recovery action is successfully taken by system software.

For the Data-Load and the Instruction-Fetch recoverable errors, system software may take the following recovery actions for the affected logical processor:

- The current executing thread cannot be continued. You must terminate the interrupted stream of execution and provide a new stream of execution on return from the machine check handler for the affected logical processor

In addition to taking the recovery action described above, system software may also need to disable the use of the affected page from the program. This recovery action by system software may prevent the occurrence of future consumption errors from that affected page.

### 15.9.4 Multiple MCA Errors

When multiple MCA errors are detected within a certain detection window, the processor may aggregate the reporting of these errors together as a single event, i.e. a single machine exception condition. If this occurs, system software may find multiple MCA errors logged in different MC banks on one logical processor or find multiple MCA errors logged across different processors for a single machine check broadcast event. In order to handle multiple UCR errors reported from a single machine check event and possibly recover from multiple errors, system software may consider the following:

- Whether it can recover from multiple errors is determined by the most severe error reported on the system. If the most severe error is found to be an unrecoverable error (VAL=1, UC=1, PCC=1 and EN=1) after system software examines the MC banks of all processors to which the MCA signal is broadcast, recovery from the multiple errors is not possible and system software needs to reset the system.
- When multiple recoverable errors are reported and no other fatal condition (e.g., overflowed condition for SRAR error) is found for the reported recoverable errors, it is possible for system software to recover from the multiple recoverable errors by taking necessary recovery action for each individual recoverable error. However, system software can no longer expect one to one relationship with the error information recorded in the IA32\_MCI\_STATUS register and the states of the RIPV and EIPV flags in the IA32\_MCG\_STATUS register as the states of the RIPV and the EIPV flags in the IA32\_MCG\_STATUS register may indicate the information for the most severe error recorded on the processor. System software is required to use the RIPV flag indication in the IA32\_MCG\_STATUS register to make a final decision of recoverability of the errors and find the

restart-ability requirement after examining each IA32\_MCi\_STATUS register error information in the MC banks.

## 15.9.5 Machine-Check Error Codes Interpretation

Chapter 16, “Interpreting Machine-Check Error Codes,” provides information on interpreting the MCA error code, model-specific error code, and other information error code fields. For P6 family processors, information has been included on decoding external bus errors. For Pentium 4 and Intel Xeon processors; information is included on external bus, internal timer and cache hierarchy errors.

## 15.10 GUIDELINES FOR WRITING MACHINE-CHECK SOFTWARE

The machine-check architecture and error logging can be used in three different ways:

- To detect machine errors during normal instruction execution, using the machine-check exception (#MC).
- To periodically check and log machine errors.
- To examine recoverable UCR errors, determine software recoverability and perform recovery actions via a machine-check exception handler or a corrected machine-check interrupt handler.

To use the machine-check exception, the operating system or executive software must provide a machine-check exception handler. This handler may need to be designed specifically for each family of processors.

A special program or utility is required to log machine errors.

Guidelines for writing a machine-check exception handler or a machine-error logging utility are given in the following sections.

### 15.10.1 Machine-Check Exception Handler

The machine-check exception (#MC) corresponds to vector 18. To service machine-check exceptions, a trap gate must be added to the IDT. The pointer in the trap gate must point to a machine-check exception handler. Two approaches can be taken to designing the exception handler:

1. The handler can merely log all the machine status and error information, then call a debugger or shut down the system.
2. The handler can analyze the reported error information and, in some cases, attempt to correct the error and restart the processor.

## MACHINE-CHECK ARCHITECTURE

For Pentium 4, Intel Xeon, P6 family, and Pentium processors; virtually all machine-check conditions cannot be corrected (they result in abort-type exceptions). The logging of status and error information is therefore a baseline implementation requirement.

When recovery from a machine-check error may be possible, consider the following when writing a machine-check exception handler:

- To determine the nature of the error, the handler must read each of the error-reporting register banks. The count field in the IA32\_MCG\_CAP register gives number of register banks. The first register of register bank 0 is at address 400H.
- The VAL (valid) flag in each IA32\_MCi\_STATUS register indicates whether the error information in the register is valid. If this flag is clear, the registers in that bank do not contain valid error information and do not need to be checked.
- To write a portable exception handler, only the MCA error code field in the IA32\_MCi\_STATUS register should be checked. See Section 15.9, “Interpreting the MCA Error Codes,” for information that can be used to write an algorithm to interpret this field.
- The RIPV, PCC, and OVER flags in each IA32\_MCi\_STATUS register indicate whether recovery from the error is possible. If PCC or OVER are set, recovery is not possible. If RIPV is not set, program execution can not be restarted reliably. When recovery is not possible, the handler typically records the error information and signals an abort to the operating system.
- Correctable errors are corrected automatically by the processor. The UC flag in each IA32\_MCi\_STATUS register indicates whether the processor automatically corrected an error.
- The RIPV flag in the IA32\_MCG\_STATUS register indicates whether the program can be restarted at the instruction indicated by the instruction pointer (the address of the instruction pushed on the stack when the exception was generated). If this flag is clear, the processor may still be able to be restarted (for debugging purposes) but not without loss of program continuity.
- For unrecoverable errors, the EIPV flag in the IA32\_MCG\_STATUS register indicates whether the instruction indicated by the instruction pointer pushed on the stack (when the exception was generated) is related to the error. If the flag is clear, the pushed instruction may not be related to the error.
- The MCIP flag in the IA32\_MCG\_STATUS register indicates whether a machine-check exception was generated. Before returning from the machine-check exception handler, software should clear this flag so that it can be used reliably by an error logging utility. The MCIP flag also detects recursion. The machine-check architecture does not support recursion. When the processor detects machine-check recursion, it enters the shutdown state.

Example 15-2 gives typical steps carried out by a machine-check exception handler.

### Example 15-2. Machine-Check Exception Handler Pseudocode

IF CPU supports MCE

```

THEN
  IF CPU supports MCA
    THEN
      call errorlogging routine; (* returns restartability *)
    FI;
  ELSE (* Pentium(R) processor compatible *)
    READ P5_MC_ADDR
    READ P5_MC_TYPE;
    report RESTARTABILITY to console;
  FI;
IF error is not restartable
  THEN
    report RESTARTABILITY to console;
    abort system;
  FI;
CLEAR MCIP flag in IA32_MCG_STATUS;

```

### 15.10.2 Pentium Processor Machine-Check Exception Handling

Machine-check exception handler on P6 family and later processor families, should follow the guidelines described in Section 15.10.1 and Example 15-2 that check the processor's support of MCA.

#### NOTE

On processors that support MCA (CPUID.1.EDX.MCA = 1) reading the P5\_MC\_TYPE and P5\_MC\_ADDR registers may produce invalid data.

When machine-check exceptions are enabled for the Pentium processor (MCE flag is set in control register CR4), the machine-check exception handler uses the RDMSR instruction to read the error type from the P5\_MC\_TYPE register and the machine check address from the P5\_MC\_ADDR register. The handler then normally reports these register values to the system console before aborting execution (see Example 15-2).

### 15.10.3 Logging Correctable Machine-Check Errors

The error handling routine for servicing the machine-check exceptions is responsible for logging uncorrected errors.

If a machine-check error is correctable, the processor does not generate a machine-check exception for it. To detect correctable machine-check errors, a utility program must be written that reads each of the machine-check error-reporting register banks and logs the results in an accounting file or data structure. This utility can be implemented in either of the following ways.

- A system daemon that polls the register banks on an infrequent basis, such as hourly or daily.

## MACHINE-CHECK ARCHITECTURE

- A user-initiated application that polls the register banks and records the exceptions. Here, the actual polling service is provided by an operating-system driver or through the system call interface.
- An interrupt service routine servicing CMCI can read the MC banks and log the error.

Example 15-3 gives pseudocode for an error logging utility.

### Example 15-3. Machine-Check Error Logging Pseudocode

Assume that execution is restartable;

```
IF the processor supports MCA
  THEN
    FOR each bank of machine-check registers
      DO
        READ IA32_MCi_STATUS;
        IF VAL flag in IA32_MCi_STATUS = 1
          THEN
            IF ADDRv flag in IA32_MCi_STATUS = 1
              THEN READ IA32_MCi_ADDR;
            FI;
            IF MISCv flag in IA32_MCi_STATUS = 1
              THEN READ IA32_MCi_MISC;
            FI;
            IF MCIP flag in IA32_MCG_STATUS = 1
              (* Machine-check exception is in progress *)
              AND PCC flag in IA32_MCi_STATUS = 1
              OR RIPV flag in IA32_MCG_STATUS = 0
              (* execution is not restartable *)
              THEN
                RESTARTABILITY = FALSE;
                return RESTARTABILITY to calling procedure;
            FI;
            Save time-stamp counter and processor ID;
            Set IA32_MCi_STATUS to all 0s;
            Execute serializing instruction (i.e., CPUID);
          FI;
      OD;
  FI;
```

If the processor supports the machine-check architecture, the utility reads through the banks of error-reporting registers looking for valid register entries. It then saves the values of the IA32\_MCi\_STATUS, IA32\_MCi\_ADDR, IA32\_MCi\_MISC and IA32\_MCG\_STATUS registers for each bank that is valid. The routine minimizes processing time by recording the raw data into a system data structure or file, reducing the overhead associated with polling. User utilities analyze the collected data in an off-line environment.

When the MCIP flag is set in the IA32\_MCG\_STATUS register, a machine-check exception is in progress and the machine-check exception handler has called the exception logging routine.

Once the logging process has been completed the exception-handling routine must determine whether execution can be restarted, which is usually possible when damage has not occurred (The PCC flag is clear, in the IA32\_MCI\_STATUS register) and when the processor can guarantee that execution is restartable (the RIPV flag is set in the IA32\_MCG\_STATUS register). If execution cannot be restarted, the system is not recoverable and the exception-handling routine should signal the console appropriately before returning the error status to the Operating System kernel for subsequent shutdown.

The machine-check architecture allows buffering of exceptions from a given error-reporting bank although the Pentium 4, Intel Xeon, and P6 family processors do not implement this feature. The error logging routine should provide compatibility with future processors by reading each hardware error-reporting bank's IA32\_MCI\_STATUS register and then writing 0s to clear the OVER and VAL flags in this register. The error logging utility should re-read the IA32\_MCI\_STATUS register for the bank ensuring that the valid bit is clear. The processor will write the next error into the register bank and set the VAL flags.

Additional information that should be stored by the exception-logging routine includes the processor's time-stamp counter value, which provides a mechanism to indicate the frequency of exceptions. A multiprocessing operating system stores the identity of the processor node incurring the exception using a unique identifier, such as the processor's APIC ID (see Section 10.8, "Handling Interrupts").

The basic algorithm given in Example 15-3 can be modified to provide more robust recovery techniques. For example, software has the flexibility to attempt recovery using information unavailable to the hardware. Specifically, the machine-check exception handler can, after logging carefully analyze the error-reporting registers when the error-logging routine reports an error that does not allow execution to be restarted. These recovery techniques can use external bus related model-specific information provided with the error report to localize the source of the error within the system and determine the appropriate recovery strategy.

## 15.10.4 Machine-Check Software Handler Guidelines for Error Recovery

### 15.10.4.1 Machine-Check Exception Handler for Error Recovery

When writing a machine-check exception (MCE) handler to support software recovery from Uncorrected Recoverable (UCR) errors, consider the following:

- When IA32\_MCG\_CAP [24] is zero, there are no recoverable errors supported and all machine-check are fatal exceptions. The logging of status and error information is therefore a baseline implementation requirement.
- When IA32\_MCG\_CAP [24] is 1, certain uncorrected errors called uncorrected recoverable (UCR) errors may be software recoverable. The handler can analyze



the reported error information, and in some cases attempt to recover from the uncorrected error and continue execution.

- For processors on which CPUID reports DisplayFamily\_DisplayModel as 06H\_0EH and onward, an MCA signal is broadcast to all logical processors in the system (see CPUID instruction in Chapter 3, "Instruction Set Reference, A-L" in the *Intel® 64 and IA-32 Architectures Software Developer's Manual, Volume 2A*). Due to the potentially shared machine check MSR resources among the logical processors on the same package/core, the MCE handler may be required to synchronize with the other processors that received a machine check error and serialize access to the machine check registers when analyzing, logging and clearing the information in the machine check registers.
- The VAL (valid) flag in each IA32\_MCi\_STATUS register indicates whether the error information in the register is valid. If this flag is clear, the registers in that bank do not contain valid error information and should not be checked.
- The MCE handler is primarily responsible for processing uncorrected errors. The UC flag in each IA32\_MCi\_Status register indicates whether the reported error was corrected (UC=0) or uncorrected (UC=1). The MCE handler can optionally log and clear the corrected errors in the MC banks if it can implement software algorithm to avoid the undesired race conditions with the CMCI or CMC polling handler.
- For uncorrectable errors, the EIPV flag in the IA32\_MCG\_STATUS register indicates (when set) that the instruction pointed to by the instruction pointer pushed onto the stack when the machine-check exception is generated is directly associated with the error. When this flag is cleared, the instruction pointed to may not be associated with the error.
- The MCIP flag in the IA32\_MCG\_STATUS register indicates whether a machine-check exception was generated. When a machine check exception is generated, it is expected that the MCIP flag in the IA32\_MCG\_STATUS register is set to 1. If it is not set, this machine check was generated by either an INT 18 instruction or some piece of hardware signaling an interrupt with vector 18.

When IA32\_MCG\_CAP [24] is 1, the following rules can apply when writing a machine check exception (MCE) handler to support software recovery:

- The PCC flag in each IA32\_MCi\_STATUS register indicates whether recovery from the error is possible for uncorrected errors (UC=1). If the PCC flag is set for uncorrected errors (UC=1), recovery is not possible. When recovery is not possible, the MCE handler typically records the error information and signals the operating system to reset the system.
- The RIPV flag in the IA32\_MCG\_STATUS register indicates whether restarting the program execution from the instruction pointer saved on the stack for the machine check exception is possible. When the RIPV is set, program execution can be restarted reliably when recovery is possible. If the RIPV flag is not set, program execution cannot be restarted reliably. In this case the recovery algorithm may involve terminating the current program execution and resuming an alternate thread of execution upon return from the machine check handler

when recovery is possible. When recovery is not possible, the MCE handler signals the operating system to reset the system.

- When the EN flag is zero but the VAL and UC flags are one in the IA32\_MCi\_STATUS register, the reported uncorrected error in this bank is not enabled. As uncorrected errors with the EN flag = 0 are not the source of machine check exceptions, the MCE handler should log and clear non-enabled errors when the S bit is set and should continue searching for enabled errors from the other IA32\_MCi\_STATUS registers. Note that when IA32\_MCG\_CAP [24] is 0, any uncorrected error condition (VAL =1 and UC=1) including the one with the EN flag cleared are fatal and the handler must signal the operating system to reset the system. For the errors that do not generate machine check exceptions, the EN flag has no meaning. See Chapter 19: Table 19-11 to find the errors that do not generate machine check exceptions.
- When the VAL flag is one, the UC flag is one, the EN flag is one and the PCC flag is zero in the IA32\_MCi\_STATUS register, the error in this bank is an uncorrected recoverable (UCR) error. The MCE handler needs to examine the S flag and the AR flag to find the type of the UCR error for software recovery and determine if software error recovery is possible.
- When both the S and the AR flags are clear in the IA32\_MCi\_STATUS register for the UCR error (VAL=1, UC=1, EN=x and PCC=0), the error in this bank is an uncorrected no-action required error (UCNA). UCNA errors are uncorrected but do not require any OS recovery action to continue execution. These errors indicate that some data in the system is corrupt, but that data has not been consumed and may not be consumed. If that data is consumed a non-UNCA machine check exception will be generated. UCNA errors are signaled in the same way as corrected machine check errors and the CMCI and CMC polling handler is primarily responsible for handling UCNA errors. Like corrected errors, the MCA handler can optionally log and clear UCNA errors as long as it can avoid the undesired race condition with the CMCI or CMC polling handler. As UCNA errors are not the source of machine check exceptions, the MCA handler should continue searching for uncorrected or software recoverable errors in all other MC banks.
- When the S flag in the IA32\_MCi\_STATUS register is set for the UCR error ((VAL=1, UC=1, EN=1 and PCC=0), the error in this bank is software recoverable and it was signaled through a machine-check exception. The AR flag in the IA32\_MCi\_STATUS register further clarifies the type of the software recoverable errors.
- When the AR flag in the IA32\_MCi\_STATUS register is clear for the software recoverable error (VAL=1, UC=1, EN=1, PCC=0 and S=1), the error in this bank is a software recoverable action optional (SRAO) error. The MCE handler and the operating system can analyze the IA32\_MCi\_STATUS [15:0] to implement MCA error code specific optional recovery action, but this recovery action is optional. System software can resume the program execution from the instruction pointer saved on the stack for the machine check exception when the RIPV flag in the IA32\_MCG\_STATUS register is set.

- When the OVER flag in the IA32\_MCi\_STATUS register is set for the SRAO error (VAL=1, UC=1, EN=1, PCC=0, S=1 and AR=0), the MCE handler cannot take recovery action as the information of the SRAO error in the IA32\_MCi\_STATUS register was potentially lost due to the overflow condition. Since the recovery action for SRAO errors is optional, restarting the program execution from the instruction pointer saved on the stack for the machine check exception is still possible for the overflowed SRAO error if the RIPV flag in the IA32\_MCG\_STATUS is set.
- When the AR flag in the IA32\_MCi\_STATUS register is set for the software recoverable error (VAL=1, UC=1, EN=1, PCC=0 and S=1), the error in this bank is a software recoverable action required (SRAR) error. The MCE handler and the operating system must take recovery action in order to continue execution after the machine-check exception. The MCA handler and the operating system need to analyze the IA32\_MCi\_STATUS [15:0] to determine the MCA error code specific recovery action. If no recovery action can be performed, the operating system must reset the system.
- When the OVER flag in the IA32\_MCi\_STATUS register is set for the SRAR error (VAL=1, UC=1, EN=1, PCC=0, S=1 and AR=1), the MCE handler cannot take recovery action as the information of the SRAR error in the IA32\_MCi\_STATUS register was potentially lost due to the overflow condition. Since the recovery action for SRAR errors must be taken, the MCE handler must signal the operating system to reset the system.
- When the MCE handler cannot find any uncorrected (VAL=1, UC=1 and EN=1) or any software recoverable errors (VAL=1, UC=1, EN=1, PCC=0 and S=1) in any of the IA32\_MCi banks of the processors, this is an unexpected condition for the MCE handler and the handler should signal the operating system to reset the system.
- Before returning from the machine-check exception handler, software must clear the MCIP flag in the IA32\_MCG\_STATUS register. The MCIP flag is used to detect recursion. The machine-check architecture does not support recursion. When the processor receives a machine check when MCIP is set, it automatically enters the shutdown state.

Example 15-4 gives pseudocode for an MC exception handler that supports recovery of UCR.

### Example 15-4. Machine-Check Error Handler Pseudocode Supporting UCR

```
MACHINE CHECK HANDLER: (* Called from INT 18 handler *)
NOERROR = TRUE;
ProcessorCount = 0;
IF CPU supports MCA
    THEN
        RESTARTABILITY = TRUE;
        IF (Processor Family = 6 AND DisplayModel ≥ 0EH) OR (Processor Family > 6)
            THEN
                MCA_BROADCAST = TRUE;
```

```

        Acquire SpinLock;
        ProcessorCount++; (* Allowing one logical processor at a time to examine machine check
registers *)
        CALL MCA ERROR PROCESSING; (* returns RESTARTABILITY and NOERROR *)
    ELSE
        MCA_BROADCAST = FALSE;
        (* Implement a rendezvous mechanism with the other processors if necessary *)
        CALL MCA ERROR PROCESSING;
    FI;
ELSE (* Pentium(R) processor compatible *)
    READ P5_MC_ADDR;
    READ P5_MC_TYPE;
    RESTARTABILITY = FALSE;
FI;

IF NOERROR = TRUE
    THEN
        IF NOT (MCG_RIPV = 1 AND MCG_EIPV = 0)
            THEN
                RESTARTABILITY = FALSE;
            FI
        FI;

IF RESTARTABILITY = FALSE
    THEN
        Report RESTARTABILITY to console;
        Reset system;
FI;

IF MCA_BROADCAST = TRUE
    THEN
        IF ProcessorCount = MAX_PROCESSORS
            AND NOERROR = TRUE
            THEN
                Report RESTARTABILITY to console;
                Reset system;
            FI;
        Release SpinLock;
        Wait till ProcessorCount = MAX_PROCESSORS on system;
        (* implement a timeout and abort function if necessary *)
    FI;
CLEAR MCIP flag in IA32_MCG_STATUS;
RESUME Execution;
(* End of MACHINE CHECK HANDLER*)

```

```

MCA ERROR PROCESSING: (* MCA Error Processing Routine called from MCA Handler *)
IF MCIP flag in IA32_MCG_STATUS = 0
    THEN (* MCIP=0 upon MCA is unexpected *)
        RESTARTABILITY = FALSE;
    FI;
FOR each bank of machine-check registers

```

## MACHINE-CHECK ARCHITECTURE

```
DO
  CLEAR_MC_BANK = FALSE;
  READ IA32_MCi_STATUS;
  IF VAL Flag in IA32_MCi_STATUS = 1
    THEN
      IF UC Flag in IA32_MCi_STATUS = 1
        THEN
          IF Bit 24 in IA32_MCG_CAP = 0
            THEN (* the processor does not support software error recovery *)
              RESTARTABILITY = FALSE;
              NOERROR = FALSE;
              GOTO LOG MCA REGISTER;
          FI;
          (* the processor supports software error recovery *)
          IF EN Flag in IA32_MCi_STATUS = 0 AND OVER Flag in IA32_MCi_STATUS=0
            THEN (* It is a spurious MCA Log. Log and clear the register *)
              CLEAR_MC_BANK = TRUE;
              GOTO LOG MCA REGISTER;
          FI;
          IF PCC Flag in IA32_MCi_STATUS = 1
            THEN (* processor context might have been corrupted *)
              RESTARTABILITY = FALSE;
            ELSE (* It is an uncorrected recoverable (UCR) error *)
              IF S Flag in IA32_MCi_STATUS = 0
                THEN
                  IF AR Flag in IA32_MCi_STATUS = 0
                    THEN (* It is an uncorrected no action required (UCNA) error *)
                      GOTO CONTINUE; (* let CMCI and CMC polling handler to process *)
                  ELSE
                    FSTARTABILITY = FALSE; (* S=0, AR=1 is illegal *)
                  FI
                FI;
              IF RESTARTABILITY = FALSE
                THEN (* no need to take recovery action if RESTARTABILITY is already false *)
                  NOERROR = FALSE;
                  GOTO LOG MCA REGISTER;
              FI;
              (* S in IA32_MCi_STATUS = 1 *)
              IF AR Flag in IA32_MCi_STATUS = 1
                THEN (* It is a software recoverable and action required (SRAR) error *)
                  IF OVER Flag in IA32_MCi_STATUS = 1
                    THEN
                      RESTARTABILITY = FALSE;
                      NOERROR = FALSE;
                      GOTO LOG MCA REGISTER;
                    FI
                  IF MCACOD Value in IA32_MCi_STATUS is recognized
                    AND Current Processor is an Affected Processor
                    THEN
                      Implement MCACOD specific recovery action;
                      CLEAR_MC_BANK = TRUE;
                    ELSE
```

```

        RESTARTABILITY = FALSE;
    FI;
    ELSE (* It is a software recoverable and action optional (SRAO) error *)
        IF OVER Flag in IA32_MCI_STATUS = 0 AND
            MCACOD in IA32_MCI_STATUS is recognized
        THEN
            Implement MCACOD specific recovery action;
        FI;
        CLEAR_MC_BANK = TRUE;
    FI; AR
    FI; PCC
    NOERROR = FALSE;
    GOTO LOG MCA REGISTER;
    ELSE (* It is a corrected error; continue to the next IA32_MCI_STATUS *)
        GOTO CONTINUE;
    FI; UC
    FI; VAL
LOG MCA REGISTER:
    SAVE IA32_MCI_STATUS;
    If MISCV in IA32_MCI_STATUS
    THEN
        SAVE IA32_MCI_MISC;
    FI;
    IF ADDRv in IA32_MCI_STATUS
    THEN
        SAVE IA32_MCI_ADDR;
    FI;
    IF CLEAR_MC_BANK = TRUE
    THEN
        SET all 0 to IA32_MCI_STATUS;
        If MISCV in IA32_MCI_STATUS
        THEN
            SET all 0 to IA32_MCI_MISC;
        FI;
        IF ADDRv in IA32_MCI_STATUS
        THEN
            SET all 0 to IA32_MCI_ADDR;
        FI;
    FI;
    CONTINUE:
    OD;
(*END FOR *)
RETURN;
(* End of MCA ERROR PROCESSING*)

```

#### 15.10.4.2 Corrected Machine-Check Handler for Error Recovery

When writing a corrected machine check handler, which is invoked as a result of CMCI or called from an OS CMC Polling dispatcher, consider the following:

- The VAL (valid) flag in each IA32\_MCi\_STATUS register indicates whether the error information in the register is valid. If this flag is clear, the registers in that bank does not contain valid error information and does not need to be checked.
- The CMCI or CMC polling handler is responsible for logging and clearing corrected errors. The UC flag in each IA32\_MCi\_Status register indicates whether the reported error was corrected (UC=0) or not (UC=1).
- When IA32\_MCG\_CAP [24] is one, the CMC handler is also responsible for logging and clearing uncorrected no-action required (UCNA) errors. When the UC flag is one but the PCC, S, and AR flags are zero in the IA32\_MCi\_STATUS register, the reported error in this bank is an uncorrected no-action required (UCNA) error.
- In addition to corrected errors and UCNA errors, the CMC handler optionally logs uncorrected (UC=1 and PCC=1), software recoverable machine check errors (UC=1, PCC=0 and S=1), but should avoid clearing those errors from the MC banks. Clearing these errors may result in accidentally removing these errors before these errors are actually handled and processed by the MCE handler for attempted software error recovery.

Example 15-5 gives pseudocode for a CMCI handler with UCR support.

### Example 15-5. Corrected Error Handler Pseudocode with UCR Support

Corrected Error HANDLER: (\* Called from CMCI handler or OS CMC Polling Dispatcher\*)

IF CPU supports MCA

THEN

FOR each bank of machine-check registers

DO

READ IA32\_MCi\_STATUS;

IF VAL flag in IA32\_MCi\_STATUS = 1

THEN

IF UC Flag in IA32\_MCi\_STATUS = 0 (\* It is a corrected error \*)

THEN

GOTO LOG CMC ERROR;

ELSE

IF Bit 24 in IA32\_MCG\_CAP = 0

THEN

GOTO CONTINUE;

FI;

IF S Flag in IA32\_MCi\_STATUS = 0 AND AR Flag in IA32\_MCi\_STATUS = 0

THEN (\* It is a uncorrected no action required error \*)

GOTO LOG CMC ERROR

FI

IF EN Flag in IA32\_MCi\_STATUS = 0

THEN (\* It is a spurious MCA error \*)

GOTO LOG CMC ERROR

FI;

FI;

FI;

GOTO CONTINUE;

```
LOG CMC ERROR:
  SAVE IA32_MCi_STATUS;
  If MISCV Flag in IA32_MCi_STATUS
    THEN
      SAVE IA32_MCi_MISC;
      SET all 0 to IA32_MCi_MISC;
    FI;
  IF ADDRv Flag in IA32_MCi_STATUS
    THEN
      SAVE IA32_MCi_ADDR;
      SET all 0 to IA32_MCi_ADDR;
    FI;
  SET all 0 to IA32_MCi_STATUS;
  CONTINUE:
OD;
(*END FOR *)
FI;
```



# CHAPTER 16

## INTERPRETING MACHINE-CHECK ERROR CODES

---

Encoding of the model-specific and other information fields is different across processor families. The differences are documented in the following sections.

### 16.1 INCREMENTAL DECODING INFORMATION: PROCESSOR FAMILY 06H MACHINE ERROR CODES FOR MACHINE CHECK

Section 16.1 provides information for interpreting additional model-specific fields for external bus errors relating to processor family 06H. The references to processor family 06H refers to only IA-32 processors with CPUID signatures listed in Table 16-1.

**Table 16-1. CPUID DisplayFamily\_DisplayModel Signatures for Processor Family 06H**

DisplayFamily_DisplayModel	Processor Families/Processor Number Series
06_0EH	Intel Core Duo, Intel Core Solo processors
06_0DH	Intel Pentium M processor
06_09H	Intel Pentium M processor
06_7H, 06_08H, 06_0AH, 06_0BH	Intel Pentium III Xeon Processor, Intel Pentium III Processor
06_03H, 06_05H	Intel Pentium II Xeon Processor, Intel Pentium II Processor
06_01H	Intel Pentium Pro Processor

These errors are reported in the IA32\_MCi\_STATUS MSRs. They are reported architecturally) as compound errors with a general form of *0000 1PPT RRRR IILL* in the MCA error code field. See Chapter 15 for information on the interpretation of compound error codes. Incremental decoding information is listed in Table 16-2.

**Table 16-2. Incremental Decoding Information: Processor Family 06H  
Machine Error Codes For Machine Check**

Type	Bit No.	Bit Function	Bit Description
MCA error codes <sup>1</sup>	0-15		
Model specific errors	16-18	Reserved	Reserved
Model specific errors	19-24	Bus queue request type	000000 for BQ_DCU_READ_TYPE error 000010 for BQ_IFU_DEMAND_TYPE error 000011 for BQ_IFU_DEMAND_NC_TYPE error 000100 for BQ_DCU_RFO_TYPE error 000101 for BQ_DCU_RFO_LOCK_TYPE error 000110 for BQ_DCU_ITOM_TYPE error 001000 for BQ_DCU_WB_TYPE error 001010 for BQ_DCU_WCEVICT_TYPE error 001011 for BQ_DCU_WCLINE_TYPE error 001100 for BQ_DCU_BTM_TYPE error
			001101 for BQ_DCU_INTACK_TYPE error 001110 for BQ_DCU_INVALL2_TYPE error 001111 for BQ_DCU_FLUSHL2_TYPE error 010000 for BQ_DCU_PART_RD_TYPE error 010010 for BQ_DCU_PART_WR_TYPE error 010100 for BQ_DCU_SPEC_CYC_TYPE error 011000 for BQ_DCU_IO_RD_TYPE error 011001 for BQ_DCU_IO_WR_TYPE error 011100 for BQ_DCU_LOCK_RD_TYPE error 011110 for BQ_DCU_SPLOCK_RD_TYPE error 011101 for BQ_DCU_LOCK_WR_TYPE error

**Table 16-2. Incremental Decoding Information: Processor Family 06H  
Machine Error Codes For Machine Check (Contd.)**

Type	Bit No.	Bit Function	Bit Description
Model specific errors	27-25	Bus queue error type	000 for BQ_ERR_HARD_TYPE error 001 for BQ_ERR_DOUBLE_TYPE error 010 for BQ_ERR_AERR2_TYPE error 100 for BQ_ERR_SINGLE_TYPE error 101 for BQ_ERR_AERR1_TYPE error
Model specific errors	28	FRC error	1 if FRC error active
	29	BERR	1 if BERR is driven
	30	Internal BINIT	1 if BINIT driven for this processor
	31	Reserved	Reserved
Other information	32-34	Reserved	Reserved
	35	External BINIT	1 if BINIT is received from external bus.
	36	Response parity error	This bit is asserted in IA32_MCI_STATUS if this component has received a parity error on the RS[2:0]# pins for a response transaction. The RS signals are checked by the RSP# external pin.
	37	Bus BINIT	This bit is asserted in IA32_MCI_STATUS if this component has received a hard error response on a split transaction one access that has needed to be split across the 64-bit external bus interface into two accesses).
	38	Timeout BINIT	This bit is asserted in IA32_MCI_STATUS if this component has experienced a ROB time-out, which indicates that no micro-instruction has been retired for a predetermined period of time.  A ROB time-out occurs when the 15-bit ROB time-out counter carries a 1 out of its high order bit. <sup>2</sup> The timer is cleared when a micro-instruction retires, an exception is detected by the core processor, RESET is asserted, or when a ROB BINIT occurs.

**Table 16-2. Incremental Decoding Information: Processor Family 06H  
Machine Error Codes For Machine Check (Contd.)**

Type	Bit No.	Bit Function	Bit Description
			The ROB time-out counter is prescaled by the 8-bit PIC timer which is a divide by 128 of the bus clock the bus clock is 1:2, 1:3, 1:4 of the core clock). When a carry out of the 8-bit PIC timer occurs, the ROB counter counts up by one. While this bit is asserted, it cannot be overwritten by another error.
	39-41	Reserved	Reserved
	42	Hard error	This bit is asserted in IA32_MCI_STATUS if this component has initiated a bus transactions which has received a hard error response. While this bit is asserted, it cannot be overwritten.
	43	IERR	This bit is asserted in IA32_MCI_STATUS if this component has experienced a failure that causes the IERR pin to be asserted. While this bit is asserted, it cannot be overwritten.
	44	AERR	This bit is asserted in IA32_MCI_STATUS if this component has initiated 2 failing bus transactions which have failed due to Address Parity Errors AERR asserted). While this bit is asserted, it cannot be overwritten.
	45	UECC	The Uncorrectable ECC error bit is asserted in IA32_MCI_STATUS for uncorrected ECC errors. While this bit is asserted, the ECC syndrome field will not be overwritten.
	46	CECC	The correctable ECC error bit is asserted in IA32_MCI_STATUS for corrected ECC errors.
	47-54	ECC syndrome	The ECC syndrome field in IA32_MCI_STATUS contains the 8-bit ECC syndrome only if the error was a correctable/uncorrectable ECC error and there wasn't a previous valid ECC error syndrome logged in IA32_MCI_STATUS. A previous valid ECC error in IA32_MCI_STATUS is indicated by IA32_MCI_STATUS.bit45 uncorrectable error occurred) being asserted. After processing an ECC error, machine-check handling software should clear IA32_MCI_STATUS.bit45 so that future ECC error syndromes can be logged.

**Table 16-2. Incremental Decoding Information: Processor Family 06H Machine Error Codes For Machine Check (Contd.)**

Type	Bit No.	Bit Function	Bit Description
	55-56	Reserved	Reserved.
Status register validity indicators <sup>1</sup>	57-63		

**NOTES:**

1. These fields are architecturally defined. Refer to Chapter 15, “Machine-Check Architecture,” for more information.
2. For processors with a CPUID signature of 06\_0EH, a ROB time-out occurs when the 23-bit ROB time-out counter carries a 1 out of its high order bit.

## 16.2 INCREMENTAL DECODING INFORMATION: INTEL CORE 2 PROCESSOR FAMILY MACHINE ERROR CODES FOR MACHINE CHECK

Table 16-4 provides information for interpreting additional model-specific fields for external bus errors relating to processor based on Intel Core microarchitecture, which implements the P4 bus specification. Table 16-3 lists the CPUID signatures for Intel 64 processors that are covered by Table 16-4. These errors are reported in the IA32\_MCi\_STATUS MSRs. They are reported architecturally) as compound errors with a general form of *0000 1PPT RRRR IILL* in the MCA error code field. See Chapter 15 for information on the interpretation of compound error codes.

**Table 16-3. CPUID DisplayFamily\_DisplayModel Signatures for Processors Based on Intel Core Microarchitecture**

DisplayFamily_DisplayModel	Processor Families/Processor Number Series
06_1DH	Intel Xeon Processor 7400 series.
06_17H	Intel Xeon Processor 5200, 5400 series, Intel Core 2 Quad processor Q9650.
06_0FH	Intel Xeon Processor 3000, 3200, 5100, 5300, 7300 series, Intel Core 2 Quad, Intel Core 2 Extreme, Intel Core 2 Duo processors, Intel Pentium dual-core processors

**Table 16-4. Incremental Bus Error Codes of Machine Check for Processors Based on Intel Core Microarchitecture**

Type	Bit No.	Bit Function	Bit Description
MCA error codes <sup>1</sup>	0-15		
Model specific errors	16-18	Reserved	Reserved
Model specific errors	19-24	Bus queue request type	'000001 for BQ_PREF_READ_TYPE error 000000 for BQ_DCU_READ_TYPE error 000010 for BQ_IFU_DEMAND_TYPE error 000011 for BQ_IFU_DEMAND_NC_TYPE error 000100 for BQ_DCU_RFO_TYPE error 000101 for BQ_DCU_RFO_LOCK_TYPE error 000110 for BQ_DCU_ITOM_TYPE error 001000 for BQ_DCU_WB_TYPE error 001010 for BQ_DCU_WCEVICT_TYPE error 001011 for BQ_DCU_WCLINE_TYPE error 001100 for BQ_DCU_BTM_TYPE error
			001101 for BQ_DCU_INTACK_TYPE error 001110 for BQ_DCU_INVALL2_TYPE error 001111 for BQ_DCU_FLUSHL2_TYPE error 010000 for BQ_DCU_PART_RD_TYPE error 010010 for BQ_DCU_PART_WR_TYPE error 010100 for BQ_DCU_SPEC_CYC_TYPE error 011000 for BQ_DCU_IO_RD_TYPE error 011001 for BQ_DCU_IO_WR_TYPE error 011100 for BQ_DCU_LOCK_RD_TYPE error 011110 for BQ_DCU_SPLOCK_RD_TYPE error 011101 for BQ_DCU_LOCK_WR_TYPE error 100100 for BQ_L2_WI_RFO_TYPE error 100110 for BQ_L2_WI_ITOM_TYPE error

**Table 16-4. Incremental Bus Error Codes of Machine Check for Processors Based on Intel Core Microarchitecture**

Type	Bit No.	Bit Function	Bit Description
Model specific errors	27-25	Bus queue error type	'001 for Address Parity Error '010 for Response Hard Error '011 for Response Parity Error
Model specific errors	28	MCE Driven	1 if MCE is driven
	29	MCE Observed	1 if MCE is observed
	30	Internal BINIT	1 if BINIT driven for this processor
	31	BINIT Observed	1 if BINIT is observed for this processor
Other information	32-33	Reserved	Reserved
	34	PIC and FSB data parity	Data Parity detected on either PIC or FSB access
	35	Reserved	Reserved
	36	Response parity error	This bit is asserted in IA32_MCI_STATUS if this component has received a parity error on the RS[2:0]# pins for a response transaction. The RS signals are checked by the RSP# external pin.
	37	FSB address parity	Address parity error detected: 1 = Address parity error detected 0 = No address parity error
	38	Timeout BINIT	This bit is asserted in IA32_MCI_STATUS if this component has experienced a ROB time-out, which indicates that no micro-instruction has been retired for a predetermined period of time.  A ROB time-out occurs when the 23-bit ROB time-out counter carries a 1 out of its high order bit. The timer is cleared when a micro-instruction retires, an exception is detected by the core processor, RESET is asserted, or when a ROB BINIT occurs.

**Table 16-4. Incremental Bus Error Codes of Machine Check for Processors Based on Intel Core Microarchitecture**

Type	Bit No.	Bit Function	Bit Description
			The ROB time-out counter is prescaled by the 8-bit PIC timer which is a divide by 128 of the bus clock the bus clock is 1:2, 1:3, 1:4 of the core clock). When a carry out of the 8-bit PIC timer occurs, the ROB counter counts up by one. While this bit is asserted, it cannot be overwritten by another error.
	39-41	Reserved	Reserved
	42	Hard error	This bit is asserted in IA32_MCI_STATUS if this component has initiated a bus transactions which has received a hard error response. While this bit is asserted, it cannot be overwritten.
	43	IERR	This bit is asserted in IA32_MCI_STATUS if this component has experienced a failure that causes the IERR pin to be asserted. While this bit is asserted, it cannot be overwritten.
	44	Reserved	Reserved
	45	Reserved	Reserved
	46	Reserved	Reserved
	47-54	Reserved	Reserved
	55-56	Reserved	Reserved.
Status register validity indicators <sup>1</sup>	57-63		

**NOTES:**

1. These fields are architecturally defined. Refer to Chapter 15, "Machine-Check Architecture," for more information.



## 16.2.1 Model-Specific Machine Check Error Codes for Intel Xeon Processor 7400 Series

Intel Xeon processor 7400 series has machine check register banks that generally follows the description of Chapter 15 and Section 16.2. Additional error codes specific to Intel Xeon processor 7400 series is describe in this section.

MC4\_STATUS[63:0] is the main error logging for the processor’s L3 and front side bus errors for Intel Xeon processor 7400 series. It supports the L3 Errors, Bus and Interconnect Errors Compound Error Codes in the MCA Error Code Field.

### 16.2.1.1 Processor Machine Check Status Register Incremental MCA Error Code Definition

Intel Xeon processor 7400 series use compound MCA Error Codes for logging its Bus internal machine check errors, L3 Errors, and Bus/Interconnect Errors. It defines incremental Machine Check error types (IA32\_MC6\_STATUS[15:0]) beyond those defined in Chapter 15. Table 16-5 lists these incremental MCA error code types that apply to IA32\_MC6\_STATUS. Error code details are specified in MC6\_STATUS [31:16] (see Section 16.2.2), the "Model Specific Error Code" field. The information in the "Other\_Info" field (MC4\_STATUS[56:32]) is common to the three processor error types and contains a correctable event count and specifies the MC6\_MISC register format.

**Table 16-5. Incremental MCA Error Code Types for Intel Xeon Processor 7400**

Processor MCA_Error_Code (MC6_STATUS[15:0])			
Type	Error Code	Binary Encoding	Meaning
C	Internal Error	0000 0100 0000 0000	Internal Error Type Code
B	Bus and Interconnect Error	0000 100x 0000 1111	Not used but this encoding is reserved for compatibility with other MCA implementations
		0000 101x 0000 1111	Not used but this encoding is reserved for compatibility with other MCA implementations
		0000 110x 0000 1111	Not used but this encoding is reserved for compatibility with other MCA implementations
		0000 1110 0000 1111	Bus and Interconnection Error Type Code
		0000 1111 0000 1111	Not used but this encoding is reserved for compatibility with other MCA implementations

The **Bold faced** binary encodings are the only encodings used by the processor for MC4\_STATUS[15:0].

## 16.2.2 Intel Xeon Processor 7400 Model Specific Error Code Field

### 16.2.2.1 Processor Model Specific Error Code Field Type B: Bus and Interconnect Error

Note: The Model Specific Error Code field in MC6\_STATUS (bits 31:16)

**Table 16-6. Type B Bus and Interconnect Error Codes**

Bit Num	Sub-Field Name	Description
16	FSB Request Parity	Parity error detected during FSB request phase
19:17		Reserved
20	FSB Hard Fail Response	“Hard Failure” response received for a local transaction
21	FSB Response Parity	Parity error on FSB response field detected
22	FSB Data Parity	FSB data parity error on inbound data detected
31:23	---	Reserved

### 16.2.2.2 Processor Model Specific Error Code Field Type C: Cache Bus Controller Error

**Table 16-7. Type C Cache Bus Controller Error Codes**

MC4_STATUS[31:16] (MSCE) Value	Error Description
0000_0000_0000_0001 0x0001	Inclusion Error from Core 0
0000_0000_0000_0010 0x0002	Inclusion Error from Core 1
0000_0000_0000_0011 0x0003	Write Exclusive Error from Core 0
0000_0000_0000_0100 0x0004	Write Exclusive Error from Core 1
0000_0000_0000_0101 0x0005	Inclusion Error from FSB
0000_0000_0000_0110 0x0006	SNP Stall Error from FSB
0000_0000_0000_0111 0x0007	Write Stall Error from FSB

**Table 16-7. Type C Cache Bus Controller Error Codes**

<b>MC4_STATUS[31:16] (MSCE) Value</b>	<b>Error Description</b>
0000_0000_0000_1000 0x0008	FSB Arb Timeout Error
0000_0000_0000_1010 0x000A	Inclusion Error from Core 2
0000_0000_0000_1011 0x000B	Write Exclusive Error from Core 2
0000_0010_0000_0000 0x0200	Internal Timeout error
0000_0011_0000_0000 0x0300	Internal Timeout Error
0000_0100_0000_0000 0x0400	Intel® Cache Safe Technology Queue Full Error or Disabled-ways-in-a-set overflow
0000_0101_0000_0000 0x0500	Quiet cycle Timeout Error (correctable)
1100_0000_0000_0010 0xC002	Correctable ECC event on outgoing Core 0 data
1100_0000_0000_0100 0xC004	Correctable ECC event on outgoing Core 1 data
1100_0000_0000_1000 0xC008	Correctable ECC event on outgoing Core 2 data
1110_0000_0000_0010 0xE002	Uncorrectable ECC error on outgoing Core 0 data
1110_0000_0000_0100 0xE004	Uncorrectable ECC error on outgoing Core 1 data
1110_0000_0000_1000 0xE008	Uncorrectable ECC error on outgoing Core 2 data
— all other encodings —	Reserved

## 16.3 INCREMENTAL DECODING INFORMATION: PROCESSOR FAMILY WITH CPUID DISPLAYFAMILY\_DISPLAYMODEL SIGNATURE 06\_1AH, MACHINE ERROR CODES FOR MACHINE CHECK

Table 16-8 through Table 16-12 provide information for interpreting additional model-specific fields for memory controller errors relating to the processor family with CPUID DisplayFamily\_DisplaySignature 06\_1AH, which supports Intel QuickPath Interconnect links. Incremental MC error codes related to the Intel QPI links are reported in the register banks IA32\_MC0 and IA32\_MC1, incremental error codes for internal machine check is reported in the register bank IA32\_MC7, and incremental error codes for the memory controller unit is reported in the register banks IA32\_MC8.

### 16.3.1 Intel QPI Machine Check Errors

**Table 16-8. Intel QPI Machine Check Error Codes for IA32\_MCO\_STATUS and IA32\_MC1\_STATUS**

Type	Bit No.	Bit Function	Bit Description
MCA error codes <sup>1</sup>	0-15	MCACOD	Bus error format: 1PPTRRRRIILL
Model specific errors			
	16	Header Parity	If 1, QPI Header had bad parity
	17	Data Parity	If 1, QPI Data packet had bad parity
	18	Retries Exceeded	If 1, number of QPI retries was exceeded
	19	Received Poison	If 1, Received a data packet that was marked as poisoned by the sender
	21-20	Reserved	Reserved
	22	Unsupported Message	If 1, QPI received a message encoding it does not support
	23	Unsupported Credit	If 1, QPI credit type is not supported.
	24	Receive Flit Overrun	If 1, Sender sent too many QPI flits to the receiver.
	25	Received Failed Response	If 1, Indicates that sender sent a failed response to receiver.
	26	Receiver Clock Jitter	If 1, clock jitter detected in the internal QPI clocking
	56-27	Reserved	Reserved
Status register validity indicators <sup>1</sup>	57-63		

**NOTES:**

1. These fields are architecturally defined. Refer to Chapter 15, "Machine-Check Architecture," for more information.

**Table 16-9. Intel QPI Machine Check Error Codes for IA32\_MC0\_MISC and IA32\_MC1\_MISC**

Type	Bit No.	Bit Function	Bit Description
Model specific errors <sup>1</sup>			
	7-0	QPI Opcode	Message class and opcode from the packet with the error
	13-8	RTId	QPI Request Transaction ID
	15-14	Reserved	Reserved
	18-16	RHNID	QPI Requestor/Home Node ID
	23-19	Reserved	Reserved
	24	IIB	QPI Interleave/Head Indication Bit

**NOTES:**

1. Which of these fields are valid depends on the error type.

### 16.3.2 Internal Machine Check Errors

**Table 16-10. Machine Check Error Codes for IA32\_MC7\_STATUS**

Type	Bit No.	Bit Function	Bit Description
MCA error codes <sup>1</sup>	0-15	MCACOD	
Model specific errors			
	23-16	Reserved	Reserved
	31-24	Reserved except for the following	00h - No Error 03h - Reset firmware did not complete 08h - Received an invalid CMPD 0Ah - Invalid Power Management Request 0Dh - Invalid S-state transition 11h - VID controller does not match POC controller selected 1Ah - MSID from POC does not match CPU MSID
	56-32	Reserved	Reserved
Status register validity indicators <sup>1</sup>	57-63		

**NOTES:**

1. These fields are architecturally defined. Refer to Chapter 15, "Machine-Check Architecture," for more information.

### 16.3.3 Memory Controller Errors

**Table 16-11. Incremental Memory Controller Error Codes of Machine Check for IA32\_MC8\_STATUS**

Type	Bit No.	Bit Function	Bit Description
MCA error codes <sup>1</sup>	0-15	MCACOD	Memory error format: 1MMMCCCC
Model specific errors			
	16	Read ECC error	If 1, ECC occurred on a read
	17	RAS ECC error	If 1, ECC occurred on a scrub
	18	Write parity error	If 1, bad parity on a write
	19	Redundancy loss	If 1, Error in half of redundant memory
	20	Reserved	Reserved
	21	Memory range error	If 1, Memory access out of range
	22	RTID out of range	If 1, Internal ID invalid
	23	Address parity error	If 1, bad address parity
	24	Byte enable parity error	If 1, bad enable parity
Other information	37-25	Reserved	Reserved
	52:38	CORE_ERR_CNT	Corrected error count
	56-53	Reserved	Reserved
Status register validity indicators <sup>1</sup>	57-63		

**NOTES:**

1. These fields are architecturally defined. Refer to Chapter 15, "Machine-Check Architecture," for more information.

**Table 16-12. Incremental Memory Controller Error Codes of Machine Check for IA32\_MC8\_MISC**

Type	Bit No.	Bit Function	Bit Description
Model specific errors <sup>1</sup>			
	7-0	RTId	Transaction Tracker ID
	15-8	Reserved	Reserved
	17-16	DIMM	DIMM ID which got the error
	19-18	Channel	Channel ID which got the error
	31-20	Reserved	Reserved
	63-32	Syndrome	ECC Syndrome

**NOTES:**

1. Which of these fields are valid depends on the error type.

## 16.4 INCREMENTAL DECODING INFORMATION: PROCESSOR FAMILY WITH CPUID DISPLAYFAMILY\_DISPLAYMODEL SIGNATURE 06\_2DH, MACHINE ERROR CODES FOR MACHINE CHECK

Table 16-8 through Table 16-12 provide information for interpreting additional model-specific fields for memory controller errors relating to the processor family with CPUID DisplayFamily\_DisplaySignature 06\_2DH, which supports Intel Quick-Path Interconnect links. Incremental MC error codes related to the Intel QPI links are reported in the register banks IA32\_MC6 and IA32\_MC7, incremental error codes for internal machine check error from PCU controller is reported in the register bank IA32\_MC4, and incremental error codes for the memory controller unit is reported in the register banks IA32\_MC8-IA32\_MC11.

## 16.4.1 Internal Machine Check Errors

**Table 16-13. Machine Check Error Codes for IA32\_MC4\_STATUS**

Type	Bit No.	Bit Function	Bit Description
MCA error codes <sup>1</sup>	0-15	MCACOD	
Model specific errors	19:16	Reserved except for the following	0000b - No Error 0001b - Non_IMem_Sel 0010b - I_Parity_Error 0011b - Bad_OpCode 0100b - I_Stack_Underflow 0101b - I_Stack_Overflow 0110b - D_Stack_Underflow 0111b - D_Stack_Overflow 1000b - Non-DMem_Sel 1001b - D_Parity_Error
	23-20	Reserved	Reserved
	31-24	Reserved except for the following	00h - No Error 0Dh - MC_IMC_FORCE_SR_S3_TIMEOUT 0Eh - MC_CPD_UNCPD_ST_TIMEOUT 0Fh - MC_PKGS_SAFE_WP_TIMEOUT 43h - MC_PECI_MAILBOX QUIESCE_TIMEOUT 5Ch - MC_MORE_THAN_ONE_LT_AGENT 60h - MC_INVALID_PKGS_REQ_PCH 61h - MC_INVALID_PKGS_REQ_QPI 62h - MC_INVALID_PKGS_RES_QPI 63h - MC_INVALID_PKGC_RES_PCH 64h - MC_INVALID_PKG_STATE_CONFIG 70h - MC_WATCHDG_TIMEOUT_PKGC_SLAVE 71h - MC_WATCHDG_TIMEOUT_PKGC_MASTER 70h - MC_WATCHDG_TIMEOUT_PKGS_MASTER 7ah - MC_HA_FAILSTS_CHANGE_DETECTED 81h - MC_RECOVERABLE_DIE_THERMAL_TOO_HOT



Type	Bit No.	Bit Function	Bit Description
	56-32	Reserved	Reserved
Status register validity indicators <sup>1</sup>	57-63		

**NOTES:**

1. These fields are architecturally defined. Refer to Chapter 15, "Machine-Check Architecture," for more information.

## 16.4.2 Intel QPI Machine Check Errors

**Table 16-14. Intel QPI MC Error Codes for IA32\_MC6\_STATUS and IA32\_MC7\_STATUS**

Type	Bit No.	Bit Function	Bit Description
MCA error codes <sup>1</sup>	0-15	MCACOD	Bus error format: 1PPTRRRRIILL
Model specific errors			
	56-16	Reserved	Reserved
Status register validity indicators <sup>1</sup>	57-63		

**NOTES:**

1. These fields are architecturally defined. Refer to Chapter 15, “Machine-Check Architecture,” for more information.

## 16.4.3 Integrated Memory Controller Machine Check Errors

MC error codes associated with integrated memory controllers are reported in the MSRs IA32\_MC8\_STATUS-IA32\_MC11\_STATUS. The supported error codes are follows the architectural MCACOD definition type 1MMMCCCC (see Chapter 15, “Machine-Check Architecture.”).

## 16.5 INCREMENTAL DECODING INFORMATION: PROCESSOR FAMILY 0FH MACHINE ERROR CODES FOR MACHINE CHECK

Table 16-15 provides information for interpreting additional family 0FH model-specific fields for external bus errors. These errors are reported in the IA32\_MCi\_STATUS MSRs. They are reported architecturally) as compound errors with a general form of *0000 1PPT RRRR IILL* in the MCA error code field. See Chapter 15 for information on the interpretation of compound error codes.

**Table 16-15. Incremental Decoding Information: Processor Family 0FH Machine Error Codes For Machine Check**

Type	Bit No.	Bit Function	Bit Description
MCA error codes <sup>1</sup>	0-15		
Model-specific error codes	16	FSB address parity	Address parity error detected: 1 = Address parity error detected 0 = No address parity error
	17	Response hard fail	Hardware failure detected on response
	18	Response parity	Parity error detected on response
	19	PIC and FSB data parity	Data Parity detected on either PIC or FSB access
	20	Processor Signature = 00000F04H: Invalid PIC request  All other processors: Reserved	Processor Signature = 00000F04H. Indicates error due to an invalid PIC request access was made to PIC space with w/B memory): 1 = Invalid PIC request error 0 = No Invalid PIC request error Reserved
	21	Pad state machine	The state machine that tracks P and N data-strobe relative timing has become unsynchronized or a glitch has been detected.
	22	Pad strobe glitch	Data strobe glitch
Type	Bit No.	Bit Function	Bit Description
	23	Pad address glitch	Address strobe glitch
Other Information	24-56	Reserved	Reserved
Status register validity indicators <sup>1</sup>	57-63		

**NOTES:**

1. These fields are architecturally defined. Refer to Chapter 15, “Machine-Check Architecture,” for more information.

Table 16-10 provides information on interpreting additional family 0FH, model specific fields for cache hierarchy errors. These errors are reported in one of the

IA32\_MCi\_STATUS MSRs. These errors are reported, architecturally, as compound errors with a general form of *0000 0001 RRRR TLLL* in the MCA error code field. See Chapter 15 for how to interpret the compound error code.

### 16.5.1 Model-Specific Machine Check Error Codes for Intel Xeon Processor MP 7100 Series

Intel Xeon processor MP 7100 series has 5 register banks which contains information related to Machine Check Errors. MCI\_STATUS[63:0] refers to all 5 register banks. MC0\_STATUS[63:0] through MC3\_STATUS[63:0] is the same as on previous generation of Intel Xeon processors within Family 0FH. MC4\_STATUS[63:0] is the main error logging for the processor’s L3 and front side bus errors. It supports the L3 Errors, Bus and Interconnect Errors Compound Error Codes in the MCA Error Code Field.

**Table 16-16. MCI\_STATUS Register Bit Definition**

Bit Field Name	Bits	Description
MCA_Error_Code	15:0	Specifies the machine check architecture defined error code for the machine check error condition detected. The machine check architecture defined error codes are guaranteed to be the same for all Intel Architecture processors that implement the machine check architecture. See tables below
Model_Specific_Error_Code	31:16	Specifies the model specific error code that uniquely identifies the machine check error condition detected. The model specific error codes may differ among Intel Architecture processors for the same Machine Check Error condition. See tables below
Other_Info	56:32	The functions of the bits in this field are implementation specific and are not part of the machine check architecture. Software that is intended to be portable among Intel Architecture processors should not rely on the values in this field.
PCC	57	Processor Context Corrupt flag indicates that the state of the processor might have been corrupted by the error condition detected and that reliable restarting of the processor may not be possible. When clear, this flag indicates that the error did not affect the processor’s state. This bit will always be set for MC errors which are not corrected.
ADDRV	58	MC_ADDR register valid flag indicates that the MC_ADDR register contains the address where the error occurred. When clear, this flag indicates that the MC_ADDR register does not contain the address where the error occurred. The MC_ADDR register should not be read if the ADDRv bit is clear.

**Table 16-16. MCI\_STATUS Register Bit Definition (Contd.)**

Bit Field Name	Bits	Description
MISCV	59	MC_MISC register valid flag indicates that the MC_MISC register contains additional information regarding the error. When clear, this flag indicates that the MC_MISC register does not contain additional information regarding the error. MC_MISC should not be read if the MISCV bit is not set.
EN	60	Error enabled flag indicates that reporting of the machine check exception for this error was enabled by the associated flag bit of the MC_CTL register. Note that correctable errors do not have associated enable bits in the MC_CTL register so the EN bit should be clear when a correctable error is logged.
UC	61	Error uncorrected flag indicates that the processor did not correct the error condition. When clear, this flag indicates that the processor was able to correct the event condition.
OVER	62	Machine check overflow flag indicates that a machine check error occurred while the results of a previous error were still in the register bank (i.e., the VAL bit was already set in the MC_STATUS register). The processor sets the OVER flag and software is responsible for clearing it. Enabled errors are written over disabled errors, and uncorrected errors are written over corrected events. Uncorrected errors are not written over previous valid uncorrected errors.
VAL	63	MC_STATUS register valid flag indicates that the information within the MC_STATUS register is valid. When this flag is set, the processor follows the rules given for the OVER flag in the MC_STATUS register when overwriting previously valid entries. The processor sets the VAL flag and software is responsible for clearing it.

### 16.5.1.1 Processor Machine Check Status Register MCA Error Code Definition

Intel Xeon processor MP 7100 series use compound MCA Error Codes for logging its CBC internal machine check errors, L3 Errors, and Bus/Interconnect Errors. It defines additional Machine Check error types (IA32\_MC4\_STATUS[15:0]) beyond those defined in Chapter 15. Table 16-17 lists these model-specific MCA error codes. Error code details are specified in MC4\_STATUS [31:16] (see Section 16.5.3), the "Model Specific Error Code" field. The information in the "Other\_Info" field (MC4\_STATUS[56:32]) is common to the three processor error types and contains a correctable event count and specifies the MC4\_MISC register format.

**Table 16-17. Incremental MCA Error Code for Intel Xeon Processor MP 7100**

Processor MCA_Error_Code (MC4_STATUS[15:0])			
Type	Error Code	Binary Encoding	Meaning
C	Internal Error	0000 0100 0000 0000	Internal Error Type Code
A	L3 Tag Error	0000 0001 0000 1011	L3 Tag Error Type Code
B	Bus and Interconnect Error	0000 100x 0000 1111	Not used but this encoding is reserved for compatibility with other MCA implementations
		0000 101x 0000 1111	Not used but this encoding is reserved for compatibility with other MCA implementations
		0000 110x 0000 1111	Not used but this encoding is reserved for compatibility with other MCA implementations
		0000 1110 0000 1111	Bus and Interconnection Error Type Code
		0000 1111 0000 1111	Not used but this encoding is reserved for compatibility with other MCA implementations

The **Bold faced** binary encodings are the only encodings used by the processor for MC4\_STATUS[15:0].

### 16.5.2 Other\_Info Field (all MCA Error Types)

The MC4\_STATUS[56:32] field is common to the processor's three MCA error types (A, B & C):

**Table 16-18. Other Information Field Bit Definition**

Bit Field Name	Bits	Description
39:32	8-bit Correctable Event Count	Holds a count of the number of correctable events since cold reset. This is a saturating counter; the counter begins at 1 (with the first error) and saturates at a count of 255.
41:40	MC4_MISC format type	The value in this field specifies the format of information in the MC4_MISC register. Currently, only two values are defined. Valid only when MISCV is asserted.
43:42	-	Reserved
51:44	ECC syndrome	ECC syndrome value for a correctable ECC event when the "Valid ECC syndrome" bit is asserted
52	Valid ECC syndrome	Set when correctable ECC event supplies the ECC syndrome
54:53	Threshold-Based Error Status	<p>00: No tracking - No hardware status tracking is provided for the structure reporting this event.</p> <p>01: Green - Status tracking is provided for the structure posting the event; the current status is green (below threshold).</p> <p>10: Yellow - Status tracking is provided for the structure posting the event; the current status is yellow (above threshold).</p> <p>11: Reserved for future use</p> <p>Valid only if Valid bit (bit 63) is set Undefined if the UC bit (bit 61) is set</p>
56:55	-	Reserved

## 16.5.3 Processor Model Specific Error Code Field

### 16.5.3.1 MCA Error Type A: L3 Error

Note: The Model Specific Error Code field in MC4\_STATUS (bits 31:16)

**Table 16-19. Type A: L3 Error Codes**

Bit Num	Sub-Field Name	Description	Legal Value(s)
18:16	L3 Error Code	Describes the L3 error encountered	000 - No error 001 - More than one way reporting a correctable event 010 - More than one way reporting an uncorrectable error 011 - More than one way reporting a tag hit 100 - No error 101 - One way reporting a correctable event 110 - One way reporting an uncorrectable error 111 - One or more ways reporting a correctable event while one or more ways are reporting an uncorrectable error
20:19	-	Reserved	00
31:21	-	Fixed pattern	0010_0000_000

### 16.5.3.2 Processor Model Specific Error Code Field Type B: Bus and Interconnect Error

Note: The Model Specific Error Code field in MC4\_STATUS (bits 31:16)



**Table 16-20. Type B Bus and Interconnect Error Codes**

Bit Num	Sub-Field Name	Description
16	FSB Request Parity	Parity error detected during FSB request phase
17	Core0 Addr Parity	Parity error detected on Core 0 request's address field
18	Core1 Addr Parity	Parity error detected on Core 1 request's address field
19		Reserved
20	FSB Response Parity	Parity error on FSB response field detected
21	FSB Data Parity	FSB data parity error on inbound data detected
22	Core0 Data Parity	Data parity error on data received from Core 0 detected
23	Core1 Data Parity	Data parity error on data received from Core 1 detected
24	IDS Parity	Detected an Enhanced Defer parity error (phase A or phase B)
25	FSB Inbound Data ECC	Data ECC event to error on inbound data (correctable or uncorrectable)
26	FSB Data Glitch	Pad logic detected a data strobe 'glitch' (or sequencing error)
27	FSB Address Glitch	Pad logic detected a request strobe 'glitch' (or sequencing error)
31:28	---	Reserved

Exactly one of the bits defined in the preceding table will be set for a Bus and Interconnect Error. The Data ECC can be correctable or uncorrectable (the MC4\_STATUS.UC bit, of course, distinguishes between correctable and uncorrectable cases with the Other\_Info field possibly providing the ECC Syndrome for correctable errors). All other errors for this processor MCA Error Type are uncorrectable.

### 16.5.3.3 Processor Model Specific Error Code Field Type C: Cache Bus Controller Error

**Table 16-21. Type C Cache Bus Controller Error Codes**

MC4_STATUS[31:16] (MSCE) Value	Error Description
0000_0000_0000_0001 0x0001	Inclusion Error from Core 0
0000_0000_0000_0010 0x0002	Inclusion Error from Core 1
0000_0000_0000_0011 0x0003	Write Exclusive Error from Core 0
0000_0000_0000_0100 0x0004	Write Exclusive Error from Core 1
0000_0000_0000_0101 0x0005	Inclusion Error from FSB
0000_0000_0000_0110 0x0006	SNP Stall Error from FSB
0000_0000_0000_0111 0x0007	Write Stall Error from FSB
0000_0000_0000_1000 0x0008	FSB Arb Timeout Error
0000_0000_0000_1001 0x0009	CBC OOD Queue Underflow/overflow
0000_0001_0000_0000 0x0100	Enhanced Intel SpeedStep Technology TM1-TM2 Error
0000_0010_0000_0000 0x0200	Internal Timeout error
0000_0011_0000_0000 0x0300	Internal Timeout Error
0000_0100_0000_0000 0x0400	Intel® Cache Safe Technology Queue Full Error or Disabled-ways-in-a-set overflow
1100_0000_0000_0001 0xC001	Correctable ECC event on outgoing FSB data
1100_0000_0000_0010 0xC002	Correctable ECC event on outgoing Core 0 data
1100_0000_0000_0100 0xC004	Correctable ECC event on outgoing Core 1 data
1110_0000_0000_0001 0xE001	Uncorrectable ECC error on outgoing FSB data
1110_0000_0000_0010 0xE002	Uncorrectable ECC error on outgoing Core 0 data
1110_0000_0000_0100 0xE004	Uncorrectable ECC error on outgoing Core 1 data
— all other encodings —	Reserved

All errors - except for the correctable ECC types - in this table are uncorrectable. The correctable ECC events may supply the ECC syndrome in the Other\_Info field of the MC4\_STATUS MSR..

**Table 16-22. Decoding Family 0FH Machine Check Codes for Cache Hierarchy Errors**

Type	Bit No.	Bit Function	Bit Description
MCA error codes <sup>1</sup>	0-15		
Model specific error codes	16-17	Tag Error Code	Contains the tag error code for this machine check error: 00 = No error detected 01 = Parity error on tag miss with a clean line 10 = Parity error/multiple tag match on tag hit 11 = Parity error/multiple tag match on tag miss
	18-19	Data Error Code	Contains the data error code for this machine check error: 00 = No error detected 01 = Single bit error 10 = Double bit error on a clean line 11 = Double bit error on a modified line
	20	L3 Error	This bit is set if the machine check error originated in the L3 it can be ignored for invalid PIC request errors): 1 = L3 error 0 = L2 error
	21	Invalid PIC Request	Indicates error due to invalid PIC request access was made to PIC space with WB memory): 1 = Invalid PIC request error 0 = No invalid PIC request error
	22-31	Reserved	Reserved
Other Information	32-39	8-bit Error Count	Holds a count of the number of errors since reset. The counter begins at 0 for the first error and saturates at a count of 255.
	40-56	Reserved	Reserved
Status register validity indicators <sup>1</sup>	57-63		

## INTERPRETING MACHINE-CHECK ERROR CODES

### NOTES:

1. These fields are architecturally defined. Refer to Chapter 15, "Machine-Check Architecture," for more information.

# CHAPTER 17

## DEBUGGING, BRANCH PROFILING, AND TIME-STAMP COUNTER

---

Intel 64 and IA-32 architectures provide debug facilities for use in debugging code and monitoring performance. These facilities are valuable for debugging application software, system software, and multitasking operating systems. Debug support is accessed using debug registers (DR0 through DR7) and model-specific registers (MSRs):

- Debug registers hold the addresses of memory and I/O locations called breakpoints. Breakpoints are user-selected locations in a program, a data-storage area in memory, or specific I/O ports. They are set where a programmer or system designer wishes to halt execution of a program and examine the state of the processor by invoking debugger software. A debug exception (#DB) is generated when a memory or I/O access is made to a breakpoint address.
- MSRs monitor branches, interrupts, and exceptions; they record addresses of the last branch, interrupt or exception taken and the last branch taken before an interrupt or exception.

### 17.1 OVERVIEW OF DEBUG SUPPORT FACILITIES

The following processor facilities support debugging and performance monitoring:

- **Debug exception (#DB)** — Transfers program control to a debug procedure or task when a debug event occurs.
- **Breakpoint exception (#BP)** — See breakpoint instruction (INT 3) below.
- **Breakpoint-address registers (DR0 through DR3)** — Specifies the addresses of up to 4 breakpoints.
- **Debug status register (DR6)** — Reports the conditions that were in effect when a debug or breakpoint exception was generated.
- **Debug control register (DR7)** — Specifies the forms of memory or I/O access that cause breakpoints to be generated.
- **T (trap) flag, TSS** — Generates a debug exception (#DB) when an attempt is made to switch to a task with the T flag set in its TSS.
- **RF (resume) flag, EFLAGS register** — Suppresses multiple exceptions to the same instruction.
- **TF (trap) flag, EFLAGS register** — Generates a debug exception (#DB) after every execution of an instruction.
- **Breakpoint instruction (INT 3)** — Generates a breakpoint exception (#BP) that transfers program control to the debugger procedure or task. This

instruction is an alternative way to set code breakpoints. It is especially useful when more than four breakpoints are desired, or when breakpoints are being placed in the source code.

- **Last branch recording facilities** — Store branch records in the last branch record (LBR) stack MSRs for the most recent taken branches, interrupts, and/or exceptions in MSRs. A branch record consist of a branch-from and a branch-to instruction address. Send branch records out on the system bus as branch trace messages (BTMs).

These facilities allow a debugger to be called as a separate task or as a procedure in the context of the current program or task. The following conditions can be used to invoke the debugger:

- Task switch to a specific task.
- Execution of the breakpoint instruction.
- Execution of any instruction.
- Execution of an instruction at a specified address.
- Read or write to a specified memory address/range.
- Write to a specified memory address/range.
- Input from a specified I/O address/range.
- Output to a specified I/O address/range.
- Attempt to change the contents of a debug register.

## 17.2 DEBUG REGISTERS

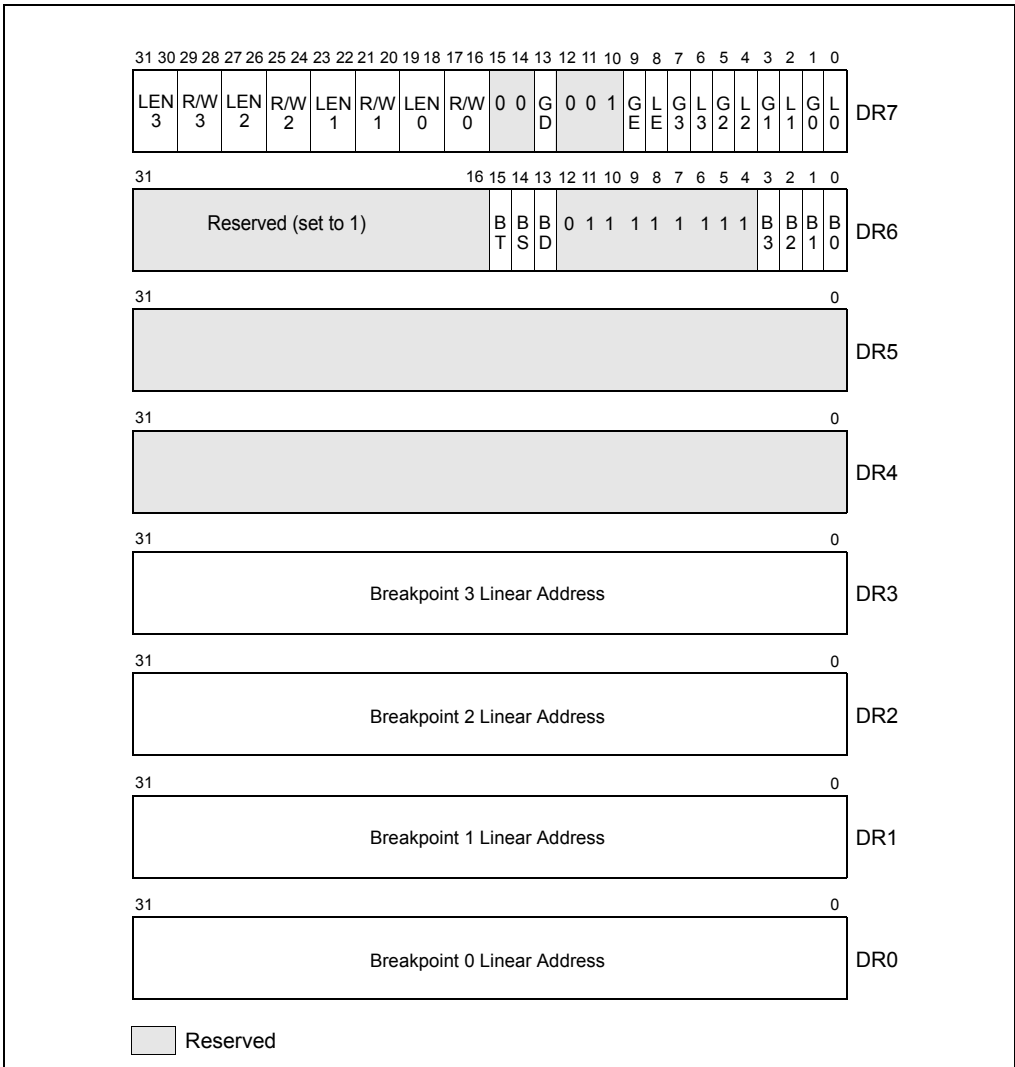
Eight debug registers (see Figure 17-1) control the debug operation of the processor. These registers can be written to and read using the move to/from debug register form of the MOV instruction. A debug register may be the source or destination operand for one of these instructions.

Debug registers are privileged resources; a MOV instruction that accesses these registers can only be executed in real-address mode, in SMM or in protected mode at a CPL of 0. An attempt to read or write the debug registers from any other privilege level generates a general-protection exception (#GP).

The primary function of the debug registers is to set up and monitor from 1 to 4 breakpoints, numbered 0 though 3. For each breakpoint, the following information can be specified:

- The linear address where the breakpoint is to occur.
- The length of the breakpoint location (1, 2, or 4 bytes).
- The operation that must be performed at the address for a debug exception to be generated.
- Whether the breakpoint is enabled.

- Whether the breakpoint condition was present when the debug exception was generated.



**Figure 17-1. Debug Registers**

The following paragraphs describe the functions of flags and fields in the debug registers.

## 17.2.1 Debug Address Registers (DR0-DR3)

Each of the debug-address registers (DR0 through DR3) holds the 32-bit linear address of a breakpoint (see Figure 17-1). Breakpoint comparisons are made before physical address translation occurs. The contents of debug register DR7 further specifies breakpoint conditions.

## 17.2.2 Debug Registers DR4 and DR5

Debug registers DR4 and DR5 are reserved when debug extensions are enabled (when the DE flag in control register CR4 is set) and attempts to reference the DR4 and DR5 registers cause invalid-opcode exceptions (#UD). When debug extensions are not enabled (when the DE flag is clear), these registers are aliased to debug registers DR6 and DR7.

## 17.2.3 Debug Status Register (DR6)

The debug status register (DR6) reports debug conditions that were sampled at the time the last debug exception was generated (see Figure 17-1). Updates to this register only occur when an exception is generated. The flags in this register show the following information:

- **B0 through B3 (breakpoint condition detected) flags (bits 0 through 3)** — Indicates (when set) that its associated breakpoint condition was met when a debug exception was generated. These flags are set if the condition described for each breakpoint by the  $LEN_n$ , and  $R/W_n$  flags in debug control register DR7 is true. They may or may not be set if the breakpoint is not enabled by the  $Ln$  or the  $Gn$  flags in register DR7. Therefore on a #DB, a debug handler should check only those B0-B3 bits which correspond to an enabled breakpoint.
- **BD (debug register access detected) flag (bit 13)** — Indicates that the next instruction in the instruction stream accesses one of the debug registers (DR0 through DR7). This flag is enabled when the GD (general detect) flag in debug control register DR7 is set. See Section 17.2.4, “Debug Control Register (DR7),” for further explanation of the purpose of this flag.
- **BS (single step) flag (bit 14)** — Indicates (when set) that the debug exception was triggered by the single-step execution mode (enabled with the TF flag in the EFLAGS register). The single-step mode is the highest-priority debug exception. When the BS flag is set, any of the other debug status bits also may be set.
- **BT (task switch) flag (bit 15)** — Indicates (when set) that the debug exception resulted from a task switch where the T flag (debug trap flag) in the TSS of the target task was set. See Section 7.2.1, “Task-State Segment (TSS),” for the format of a TSS. There is no flag in debug control register DR7 to enable or disable this exception; the T flag of the TSS is the only enabling flag.

Certain debug exceptions may clear bits 0-3. The remaining contents of the DR6 register are never cleared by the processor. To avoid confusion in identifying debug



exceptions, debug handlers should clear the register before returning to the interrupted task.

## 17.2.4 Debug Control Register (DR7)

The debug control register (DR7) enables or disables breakpoints and sets breakpoint conditions (see Figure 17-1). The flags and fields in this register control the following things:

- **L0 through L3 (local breakpoint enable) flags (bits 0, 2, 4, and 6) —** Enables (when set) the breakpoint condition for the associated breakpoint for the current task. When a breakpoint condition is detected and its associated  $L_n$  flag is set, a debug exception is generated. The processor automatically clears these flags on every task switch to avoid unwanted breakpoint conditions in the new task.
- **G0 through G3 (global breakpoint enable) flags (bits 1, 3, 5, and 7) —** Enables (when set) the breakpoint condition for the associated breakpoint for all tasks. When a breakpoint condition is detected and its associated  $G_n$  flag is set, a debug exception is generated. The processor does not clear these flags on a task switch, allowing a breakpoint to be enabled for all tasks.
- **LE and GE (local and global exact breakpoint enable) flags (bits 8, 9) —** This feature is not supported in the P6 family processors, later IA-32 processors, and Intel 64 processors. When set, these flags cause the processor to detect the exact instruction that caused a data breakpoint condition. For backward and forward compatibility with other Intel processors, we recommend that the LE and GE flags be set to 1 if exact breakpoints are required.
- **GD (general detect enable) flag (bit 13) —** Enables (when set) debug-register protection, which causes a debug exception to be generated prior to any MOV instruction that accesses a debug register. When such a condition is detected, the BD flag in debug status register DR6 is set prior to generating the exception. This condition is provided to support in-circuit emulators.

When the emulator needs to access the debug registers, emulator software can set the GD flag to prevent interference from the program currently executing on the processor.

The processor clears the GD flag upon entering to the debug exception handler, to allow the handler access to the debug registers.

- **R/W0 through R/W3 (read/write) fields (bits 16, 17, 20, 21, 24, 25, 28, and 29) —** Specifies the breakpoint condition for the corresponding breakpoint. The DE (debug extensions) flag in control register CR4 determines how the bits in the  $R/W_n$  fields are interpreted. When the DE flag is set, the processor interprets bits as follows:

- 00 — Break on instruction execution only.
- 01 — Break on data writes only.

- 10 — Break on I/O reads or writes.
- 11 — Break on data reads or writes but not instruction fetches.

When the DE flag is clear, the processor interprets the R/Wn bits the same as for the Intel386™ and Intel486™ processors, which is as follows:

- 00 — Break on instruction execution only.
  - 01 — Break on data writes only.
  - 10 — Undefined.
  - 11 — Break on data reads or writes but not instruction fetches.
- **LENO through LEN3 (Length) fields (bits 18, 19, 22, 23, 26, 27, 30, and 31)** — Specify the size of the memory location at the address specified in the corresponding breakpoint address register (DR0 through DR3). These fields are interpreted as follows:
    - 00 — 1-byte length.
    - 01 — 2-byte length.
    - 10 — Undefined (or 8 byte length, see note below).
    - 11 — 4-byte length.

If the corresponding R/Wn field in register DR7 is 00 (instruction execution), then the LENn field should also be 00. The effect of using other lengths is undefined. See Section 17.2.5, “Breakpoint Field Recognition,” below.

## NOTES

For Pentium® 4 and Intel® Xeon® processors with a CPUID signature corresponding to family 15 (model 3, 4, and 6), break point conditions permit specifying 8-byte length on data read/write with an of encoding 10B in the LENn field.

Encoding 10B is also supported in processors based on Intel Core microarchitecture or enhanced Intel Core microarchitecture, the respective CPUID signatures corresponding to family 6, model 15, and family 6, DisplayModel value 23 (see CPUID instruction in Chapter 3, “Instruction Set Reference, A-L” in the *Intel® 64 and IA-32 Architectures Software Developer’s Manual, Volume 2A*). The Encoding 10B is supported in processors based on Intel® Atom™ microarchitecture, with CPUID signature of family 6, DisplayModel value 28. The encoding 10B is undefined for other processors.

## 17.2.5 Breakpoint Field Recognition

Breakpoint address registers (debug registers DR0 through DR3) and the LENn fields for each breakpoint define a range of sequential byte addresses for a data or I/O breakpoint. The LENn fields permit specification of a 1-, 2-, 4-, or 8-byte range, beginning at the linear address specified in the corresponding debug register (DRn). Two-byte ranges must be aligned on word boundaries; 4-byte ranges must be aligned on doubleword boundaries. I/O addresses are zero-extended (from 16 to 32

bits, for comparison with the breakpoint address in the selected debug register). These requirements are enforced by the processor; it uses LEN<sub>n</sub> field bits to mask the lower address bits in the debug registers. Unaligned data or I/O breakpoint addresses do not yield valid results.

A data breakpoint for reading or writing data is triggered if any of the bytes participating in an access is within the range defined by a breakpoint address register and its LEN<sub>n</sub> field. Table 17-1 provides an example setup of debug registers and data accesses that would subsequently trap or not trap on the breakpoints.

A data breakpoint for an unaligned operand can be constructed using two breakpoints, where each breakpoint is byte-aligned and the two breakpoints together cover the operand. The breakpoints generate exceptions only for the operand, not for neighboring bytes.

Instruction breakpoint addresses must have a length specification of 1 byte (the LEN<sub>n</sub> field is set to 00). Code breakpoints for other operand sizes are undefined. The processor recognizes an instruction breakpoint address only when it points to the first byte of an instruction. If the instruction has prefixes, the breakpoint address must point to the first prefix.

**Table 17-1. Breakpoint Examples**

Debug Register Setup			
Debug Register	R/W <sub>n</sub>	Breakpoint Address	LEN <sub>n</sub>
DR0	R/W0 = 11 (Read/Write)	A0001H	LEN0 = 00 (1 byte)
DR1	R/W1 = 01 (Write)	A0002H	LEN1 = 00 (1 byte)
DR2	R/W2 = 11 (Read/Write)	B0002H	LEN2 = 01) (2 bytes)
DR3	R/W3 = 01 (Write)	C0000H	LEN3 = 11 (4 bytes)
Data Accesses			
Operation		Address	Access Length (In Bytes)
Data operations that trap			
- Read or write		A0001H	1
- Read or write		A0001H	2
- Write		A0002H	1
- Write		A0002H	2
- Read or write		B0001H	4
- Read or write		B0002H	1
- Read or write		B0002H	2
- Write		C0000H	4
- Write		C0001H	2
- Write		C0003H	1

**Table 17-1. Breakpoint Examples (Contd.)**

Debug Register Setup			
Debug Register	R/Wn	Breakpoint Address	LENn
Data operations that do not trap			
- Read or write		A0000H	1
- Read		A0002H	1
- Read or write		A0003H	4
- Read or write		B0000H	2
- Read		C0000H	2
- Read or write		C0004H	4

### 17.2.6 Debug Registers and Intel® 64 Processors

For Intel 64 architecture processors, debug registers DR0–DR7 are 64 bits. In 16-bit or 32-bit modes (protected mode and compatibility mode), writes to a debug register fill the upper 32 bits with zeros. Reads from a debug register return the lower 32 bits. In 64-bit mode, MOV DRn instructions read or write all 64 bits. Operand-size prefixes are ignored.

In 64-bit mode, the upper 32 bits of DR6 and DR7 are reserved and must be written with zeros. Writing 1 to any of the upper 32 bits results in a #GP(0) exception (see Figure 17-2). All 64 bits of DR0–DR3 are writable by software. However, MOV DRn instructions do not check that addresses written to DR0–DR3 are in the linear-address limits of the processor implementation (address matching is supported only on valid addresses generated by the processor implementation). Break point conditions for 8-byte memory read/writes are supported in all modes.

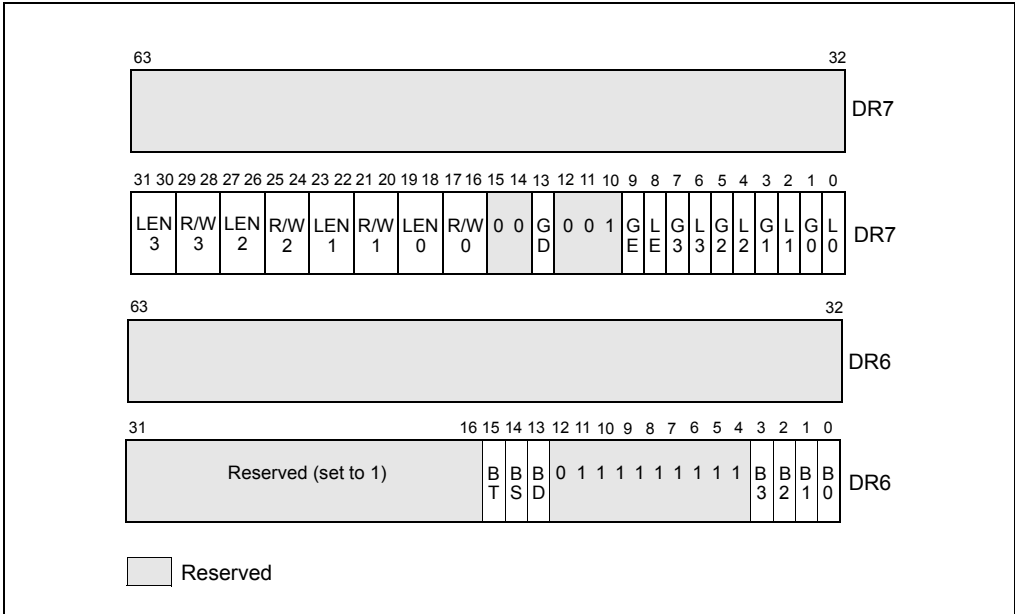


Figure 17-2. DR6/DR7 Layout on Processors Supporting Intel 64 Technology

## 17.3 DEBUG EXCEPTIONS

The Intel 64 and IA-32 architectures dedicate two interrupt vectors to handling debug exceptions: vector 1 (debug exception, #DB) and vector 3 (breakpoint exception, #BP). The following sections describe how these exceptions are generated and typical exception handler operations.

### 17.3.1 Debug Exception (#DB)—Interrupt Vector 1

The debug-exception handler is usually a debugger program or part of a larger software system. The processor generates a debug exception for any of several conditions. The debugger checks flags in the DR6 and DR7 registers to determine which condition caused the exception and which other conditions might apply. Table 17-2 shows the states of these flags following the generation of each kind of breakpoint condition.

Instruction-breakpoint and general-detect condition (see Section 17.3.1.3, “General-Detect Exception Condition”) result in faults; other debug-exception conditions result in traps. The debug exception may report one or both at one time. The following sections describe each class of debug exception.

See also: Chapter 6, “Interrupt 1—Debug Exception (#DB),” in the *Intel® 64 and IA-32 Architectures Software Developer’s Manual, Volume 3A*.

**Table 17-2. Debug Exception Conditions**

Debug or Breakpoint Condition	DR6 Flags Tested	DR7 Flags Tested	Exception Class
Single-step trap	BS = 1		Trap
Instruction breakpoint, at addresses defined by DR $n$ and LEN $n$	B $n$ = 1 and (G $n$ or L $n$ = 1)	R/W $n$ = 0	Fault
Data write breakpoint, at addresses defined by DR $n$ and LEN $n$	B $n$ = 1 and (G $n$ or L $n$ = 1)	R/W $n$ = 1	Trap
I/O read or write breakpoint, at addresses defined by DR $n$ and LEN $n$	B $n$ = 1 and (G $n$ or L $n$ = 1)	R/W $n$ = 2	Trap
Data read or write (but not instruction fetches), at addresses defined by DR $n$ and LEN $n$	B $n$ = 1 and (G $n$ or L $n$ = 1)	R/W $n$ = 3	Trap
General detect fault, resulting from an attempt to modify debug registers (usually in conjunction with in-circuit emulation)	BD = 1		Fault
Task switch	BT = 1		Trap

### 17.3.1.1 Instruction-Breakpoint Exception Condition

The processor reports an instruction breakpoint when it attempts to execute an instruction at an address specified in a breakpoint-address register (DR0 through DR3) that has been set up to detect instruction execution (R/W flag is set to 0). Upon reporting the instruction breakpoint, the processor generates a fault-class, debug exception (#DB) before it executes the target instruction for the breakpoint.

Instruction breakpoints are the highest priority debug exceptions. They are serviced before any other exceptions detected during the decoding or execution of an instruction. However, if a code instruction breakpoint is placed on an instruction located immediately after a POP SS/MOV SS instruction, the breakpoint may not be triggered. In most situations, POP SS/MOV SS will inhibit such interrupts (see “MOV—Move” and “POP—Pop a Value from the Stack” in Chapter 4 of the *Intel® 64 and IA-32 Architectures Software Developer’s Manual, Volume 2B*).

Because the debug exception for an instruction breakpoint is generated before the instruction is executed, if the instruction breakpoint is not removed by the exception handler; the processor will detect the instruction breakpoint again when the instruction is restarted and generate another debug exception. To prevent looping on an instruction breakpoint, the Intel 64 and IA-32 architectures provide the RF flag (resume flag) in the EFLAGS register (see Section 2.3, “System Flags and Fields in

the EFLAGS Register,” in the *Intel® 64 and IA-32 Architectures Software Developer’s Manual, Volume 3A*). When the RF flag is set, the processor ignores instruction breakpoints.

All Intel 64 and IA-32 processors manage the RF flag as follows. The RF Flag is cleared at the start of the instruction after the check for code breakpoint, CS limit violation and FP exceptions. Task Switches and IRETD/IRETQ instructions transfer the RF image from the TSS/stack to the EFLAGS register.

When calling an event handler, Intel 64 and IA-32 processors establish the value of the RF flag in the EFLAGS image pushed on the stack:

- For any fault-class exception except a debug exception generated in response to an instruction breakpoint, the value pushed for RF is 1.
- For any interrupt arriving after any iteration of a repeated string instruction but the last iteration, the value pushed for RF is 1.
- For any trap-class exception generated by any iteration of a repeated string instruction but the last iteration, the value pushed for RF is 1.
- For other cases, the value pushed for RF is the value that was in EFLAG.RF at the time the event handler was called. This includes:
  - Debug exceptions generated in response to instruction breakpoints
  - Hardware-generated interrupts arriving between instructions (including those arriving after the last iteration of a repeated string instruction)
  - Trap-class exceptions generated after an instruction completes (including those generated after the last iteration of a repeated string instruction)
  - Software-generated interrupts (RF is pushed as 0, since it was cleared at the start of the software interrupt)

As noted above, the processor does not set the RF flag prior to calling the debug exception handler for debug exceptions resulting from instruction breakpoints. The debug exception handler can prevent recurrence of the instruction breakpoint by setting the RF flag in the EFLAGS image on the stack. If the RF flag in the EFLAGS image is set when the processor returns from the exception handler, it is copied into the RF flag in the EFLAGS register by IRETD/IRETQ or a task switch that causes the return. The processor then ignores instruction breakpoints for the duration of the next instruction. (Note that the POPF, POPFD, and IRET instructions do not transfer the RF image into the EFLAGS register.) Setting the RF flag does not prevent other types of debug-exception conditions (such as, I/O or data breakpoints) from being detected, nor does it prevent non-debug exceptions from being generated.

For the Pentium processor, when an instruction breakpoint coincides with another fault-type exception (such as a page fault), the processor may generate one spurious debug exception after the second exception has been handled, even though the debug exception handler set the RF flag in the EFLAGS image. To prevent a spurious exception with Pentium processors, all fault-class exception handlers should set the RF flag in the EFLAGS image.

### 17.3.1.2 Data Memory and I/O Breakpoint Exception Conditions

Data memory and I/O breakpoints are reported when the processor attempts to access a memory or I/O address specified in a breakpoint-address register (DR0 through DR3) that has been set up to detect data or I/O accesses (R/W flag is set to 1, 2, or 3). The processor generates the exception after it executes the instruction that made the access, so these breakpoint condition causes a trap-class exception to be generated.

Because data breakpoints are traps, an instruction that writes memory overwrites the original data before the debug exception generated by a data breakpoint is generated. If a debugger needs to save the contents of a write breakpoint location, it should save the original contents before setting the breakpoint. The handler can report the saved value after the breakpoint is triggered. The address in the debug registers can be used to locate the new value stored by the instruction that triggered the breakpoint.

If a data breakpoint is detected during an iteration of a string instruction executed with fast-string operation (see Section 7.3.9.3 of *Intel® 64 and IA-32 Architectures Software Developer's Manual, Volume 1*), delivery of the resulting debug exception may be delayed until completion of the corresponding group of iterations.

Intel486 and later processors ignore the GE and LE flags in DR7. In Intel386 processors, exact data breakpoint matching does not occur unless it is enabled by setting the LE and/or the GE flags.

For repeated INS and OUTS instructions that generate an I/O-breakpoint debug exception, the processor generates the exception after the completion of the first iteration. Repeated INS and OUTS instructions generate a data-breakpoint debug exception after the iteration in which the memory address breakpoint location is accessed.

### 17.3.1.3 General-Detect Exception Condition

When the GD flag in DR7 is set, the general-detect debug exception occurs when a program attempts to access any of the debug registers (DR0 through DR7) at the same time they are being used by another application, such as an emulator or debugger. This protection feature guarantees full control over the debug registers when required. The debug exception handler can detect this condition by checking the state of the BD flag in the DR6 register. The processor generates the exception before it executes the MOV instruction that accesses a debug register, which causes a fault-class exception to be generated.

### 17.3.1.4 Single-Step Exception Condition

The processor generates a single-step debug exception if (while an instruction is being executed) it detects that the TF flag in the EFLAGS register is set. The exception is a trap-class exception, because the exception is generated after the instruction is executed. The processor will not generate this exception after the instruction



that sets the TF flag. For example, if the POPF instruction is used to set the TF flag, a single-step trap does not occur until after the instruction that follows the POPF instruction.

The processor clears the TF flag before calling the exception handler. If the TF flag was set in a TSS at the time of a task switch, the exception occurs after the first instruction is executed in the new task.

The TF flag normally is not cleared by privilege changes inside a task. The INT *n* and INTO instructions, however, do clear this flag. Therefore, software debuggers that single-step code must recognize and emulate INT *n* or INTO instructions rather than executing them directly. To maintain protection, the operating system should check the CPL after any single-step trap to see if single stepping should continue at the current privilege level.

The interrupt priorities guarantee that, if an external interrupt occurs, single stepping stops. When both an external interrupt and a single-step interrupt occur together, the single-step interrupt is processed first. This operation clears the TF flag. After saving the return address or switching tasks, the external interrupt input is examined before the first instruction of the single-step handler executes. If the external interrupt is still pending, then it is serviced. The external interrupt handler does not run in single-step mode. To single step an interrupt handler, single step an INT *n* instruction that calls the interrupt handler.

### 17.3.1.5 Task-Switch Exception Condition

The processor generates a debug exception after a task switch if the T flag of the new task's TSS is set. This exception is generated after program control has passed to the new task, and prior to the execution of the first instruction of that task. The exception handler can detect this condition by examining the BT flag of the DR6 register.

If entry 1 (#DB) in the IDT is a task gate, the T bit of the corresponding TSS should not be set. Failure to observe this rule will put the processor in a loop.

## 17.3.2 Breakpoint Exception (#BP)—Interrupt Vector 3

The breakpoint exception (interrupt 3) is caused by execution of an INT 3 instruction. See Chapter 6, "Interrupt 3—Breakpoint Exception (#BP)." Debuggers use break exceptions in the same way that they use the breakpoint registers; that is, as a mechanism for suspending program execution to examine registers and memory locations. With earlier IA-32 processors, breakpoint exceptions are used extensively for setting instruction breakpoints.

With the Intel386 and later IA-32 processors, it is more convenient to set breakpoints with the breakpoint-address registers (DR0 through DR3). However, the breakpoint exception still is useful for breakpointing debuggers, because a breakpoint exception can call a separate exception handler. The breakpoint exception is also useful when it is necessary to set more breakpoints than there are debug regis-

ters or when breakpoints are being placed in the source code of a program under development.

## 17.4 LAST BRANCH, INTERRUPT, AND EXCEPTION RECORDING OVERVIEW

P6 family processors introduced the ability to set breakpoints on taken branches, interrupts, and exceptions, and to single-step from one branch to the next. This capability has been modified and extended in the Pentium 4, Intel Xeon, Pentium M, Intel® Core™ Solo, Intel® Core™ Duo, Intel® Core™2 Duo, Intel® Core™ i7 and Intel® Atom™ processors to allow logging of branch trace messages in a branch trace store (BTS) buffer in memory.

See the following sections for processor specific implementation of last branch, interrupt and exception recording:

- Section 17.5, “Last Branch, Interrupt, and Exception Recording (Intel® Core™ 2 Duo and Intel® Atom™ Processor Family)”
- Section 17.6, “Last Branch, Interrupt, and Exception Recording for Processors based on Intel® Microarchitecture code name Nehalem”
- Section 17.8, “Last Branch, Interrupt, and Exception Recording (Processors based on Intel NetBurst® Microarchitecture)”
- Section 17.9, “Last Branch, Interrupt, and Exception Recording (Intel® Core™ Solo and Intel® Core™ Duo Processors)”
- Section 17.10, “Last Branch, Interrupt, and Exception Recording (Pentium M Processors)”
- Section 17.11, “Last Branch, Interrupt, and Exception Recording (P6 Family Processors)”

The following subsections of Section 17.4 describe common features of profiling branches. These features are generally enabled using the IA32\_DEBUGCTL MSR (older processor may have implemented a subset or model-specific features, see definitions of MSR\_DEBUGCTLA, MSR\_DEBUGCTLB, MSR\_DEBUGCTL).

### 17.4.1 IA32\_DEBUGCTL MSR

The **IA32\_DEBUGCTL** MSR provides bit field controls to enable debug trace interrupts, debug trace stores, trace messages enable, single stepping on branches, last branch record recording, and to control freezing of LBR stack or performance counters on a PMI request. IA32\_DEBUGCTL MSR is located at register address 01D9H.

See Figure 17-3 for the MSR layout and the bullets below for a description of the flags:

- LBR (last branch/interrupt/exception) flag (bit 0)** — When set, the processor records a running trace of the most recent branches, interrupts, and/or exceptions taken by the processor (prior to a debug exception being generated) in the last branch record (LBR) stack. For more information, see the Section 17.5.1, “LBR Stack” (Intel® Core™2 Duo and Intel® Atom™ Processor Family) and Section 17.6.1, “LBR Stack” (processors based on Intel® Microarchitecture code name Nehalem).
- BTF (single-step on branches) flag (bit 1)** — When set, the processor treats the TF flag in the EFLAGS register as a “single-step on branches” flag rather than a “single-step on instructions” flag. This mechanism allows single-stepping the processor on taken branches. See Section 17.4.3, “Single-Stepping on Branches,” for more information about the BTF flag.
- TR (trace message enable) flag (bit 6)** — When set, branch trace messages are enabled. When the processor detects a taken branch, interrupt, or exception; it sends the branch record out on the system bus as a branch trace message (BTM). See Section 17.4.4, “Branch Trace Messages,” for more information about the TR flag.
- BTS (branch trace store) flag (bit 7)** — When set, the flag enables BTS facilities to log BTMs to a memory-resident BTS buffer that is part of the DS save area. See Section 17.4.9, “BTS and DS Save Area.”
- BTINT (branch trace interrupt) flag (bit 8)** — When set, the BTS facilities generate an interrupt when the BTS buffer is full. When clear, BTMs are logged to the BTS buffer in a circular fashion. See Section 17.4.5, “Branch Trace Store (BTS),” for a description of this mechanism.

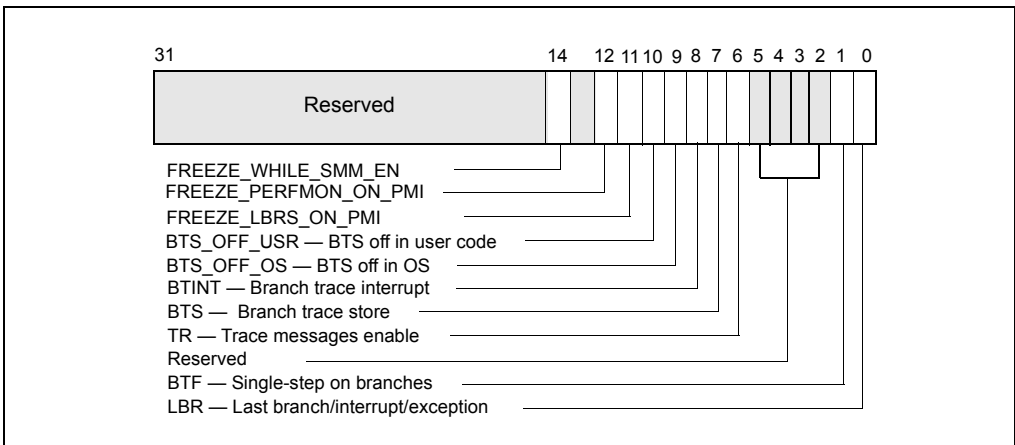


Figure 17-3. IA32\_DEBUGCTL MSR for Processors based on Intel Core microarchitecture

- **BTS\_OFF\_OS (branch trace off in privileged code) flag (bit 9)** — When set, BTS or BTM is skipped if CPL is 0. See Section 17.8.2.
- **BTS\_OFF\_USR (branch trace off in user code) flag (bit 10)** — When set, BTS or BTM is skipped if CPL is greater than 0. See Section 17.8.2.
- **FREEZE\_LBRS\_ON\_PMI flag (bit 11)** — When set, the LBR stack is frozen on a hardware PMI request (e.g. when a counter overflows and is configured to trigger PMI).
- **FREEZE\_PERFMON\_ON\_PMI flag (bit 12)** — When set, a PMI request clears each of the “ENABLE” field of MSR\_PERF\_GLOBAL\_CTRL MSR (see Figure 18-3) to disable all the counters.
- **FREEZE\_WHILE\_SMM\_EN (bit 14)** — If this bit is set, upon the delivery of an SMI, the processor will clear all the enable bits of IA32\_PERF\_GLOBAL\_CTRL, save a copy of the content of IA32\_DEBUGCTL and disable LBR, BTF, TR, and BTS fields of IA32\_DEBUGCTL before transferring control to the SMI handler. Subsequently, the enable bits of IA32\_PERF\_GLOBAL\_CTRL will be set to 1, the saved copy of IA32\_DEBUGCTL prior to SMI delivery will be restored, after the SMI handler issues RSM to complete its service. Note that system software must check IA32\_DEBUGCTL to determine if the processor supports the FREEZE\_WHILE\_SMM\_EN control bit. FREEZE\_WHILE\_SMM\_EN is supported if IA32\_PERF\_CAPABILITIES.FREEZE\_WHILE\_SMM[Bit 12] is reporting 1. See Section 18.13 for details of detecting the presence of IA32\_PERF\_CAPABILITIES MSR.

## 17.4.2 Monitoring Branches, Exceptions, and Interrupts

When the LBR flag (bit 0) in the IA32\_DEBUGCTL MSR is set, the processor automatically begins recording branch records for taken branches, interrupts, and exceptions (except for debug exceptions) in the LBR stack MSRs.

When the processor generates a debug exception (#DB), it automatically clears the LBR flag before executing the exception handler. This action does not clear previously stored LBR stack MSRs. The branch record for the last four taken branches, interrupts and/or exceptions are retained for analysis.

A debugger can use the linear addresses in the LBR stack to re-set breakpoints in the breakpoint address registers (DR0 through DR3). This allows a backward trace from the manifestation of a particular bug toward its source.

If the LBR flag is cleared and TR flag in the IA32\_DEBUGCTL MSR remains set, the processor will continue to update LBR stack MSRs. This is because BTM information must be generated from entries in the LBR stack. A #DB does not automatically clear the TR flag.

### 17.4.3 Single-Stepping on Branches

When software sets both the BTF flag (bit 1) in the IA32\_DEBUGCTL MSR and the TF flag in the EFLAGS register, the processor generates a single-step debug exception only after instructions that cause a branch.<sup>1</sup> This mechanism allows a debugger to single-step on control transfers caused by branches. This “branch single stepping” helps isolate a bug to a particular block of code before instruction single-stepping further narrows the search. The processor clears the BTF flag when it generates a debug exception. The debugger must set the BTF flag before resuming program execution to continue single-stepping on branches.

### 17.4.4 Branch Trace Messages

Setting the TR flag (bit 6) in the IA32\_DEBUGCTL MSR enables branch trace messages (BTMs). Thereafter, when the processor detects a branch, exception, or interrupt, it sends a branch record out on the system bus as a BTM. A debugging device that is monitoring the system bus can read these messages and synchronize operations with taken branch, interrupt, and exception events.

When interrupts or exceptions occur in conjunction with a taken branch, additional BTMs are sent out on the bus, as described in Section 17.4.2, “Monitoring Branches, Exceptions, and Interrupts.”

For P6 processor family, Pentium M processor family, processors based on Intel Core microarchitecture, TR and LBR bits can not be set at the same time due to hardware limitation. The content of LBR stack is undefined when TR is set.

For IA processor families based on Intel NetBurst microarchitecture, Intel microarchitecture code name Nehalem and Intel Atom processor family, the processor can collect branch records in the LBR stack and at the same time send/store BTMs when both the TR and LBR flags are set in the IA32\_DEBUGCTL MSR (or the equivalent MSR\_DEBUGCTLA, MSR\_DEBUGCTLB).

The following exception applies:

- BTM may not be observable on Intel Atom processor family processors that do not provide an externally visible system bus.

#### 17.4.4.1 Branch Trace Message Visibility

Branch trace message (BTM) visibility is implementation specific and limited to systems with a front side bus (FSB). BTMs may not be visible to newer system link interfaces or a system bus that deviates from a traditional FSB.

---

1. Executions of CALL, IRET, and JMP that cause task switches never cause single-step debug exceptions (regardless of the value of the BTF flag). A debugger desiring debug exceptions on switches to a task should set the T flag (debug trap flag) in the TSS of that task. See Section 7.2.1, “Task-State Segment (TSS).”

## 17.4.5 Branch Trace Store (BTS)

A trace of taken branches, interrupts, and exceptions is useful for debugging code by providing a method of determining the decision path taken to reach a particular code location. The LBR flag (bit 0) of IA32\_DEBUGCTL provides a mechanism for capturing records of taken branches, interrupts, and exceptions and saving them in the last branch record (LBR) stack MSRs, setting the TR flag for sending them out onto the system bus as BTMs. The branch trace store (BTS) mechanism provides the additional capability of saving the branch records in a memory-resident BTS buffer, which is part of the DS save area. The BTS buffer can be configured to be circular so that the most recent branch records are always available or it can be configured to generate an interrupt when the buffer is nearly full so that all the branch records can be saved. The BTINT flag (bit 8) can be used to enable the generation of interrupt when the BTS buffer is full. See Section 17.4.9.2, "Setting Up the DS Save Area." for additional details.

Setting this flag (BTS) alone can greatly reduce the performance of the processor. CPL-qualified branch trace storing mechanism can help mitigate the performance impact of sending/logging branch trace messages.

## 17.4.6 CPL-Qualified Branch Trace Mechanism

CPL-qualified branch trace mechanism is available to a subset of Intel 64 and IA-32 processors that support the branch trace storing mechanism. The processor supports the CPL-qualified branch trace mechanism if CPUID.01H:ECX[bit 4] = 1.

The CPL-qualified branch trace mechanism is described in Section 17.4.9.4. System software can selectively specify CPL qualification to not send/store Branch Trace Messages associated with a specified privilege level. Two bit fields, BTS\_OFF\_USR (bit 10) and BTS\_OFF\_OS (bit 9), are provided in the debug control register to specify the CPL of BTMs that will not be logged in the BTS buffer or sent on the bus.

## 17.4.7 Freezing LBR and Performance Counters on PMI

Many issues may generate a performance monitoring interrupt (PMI); a PMI service handler will need to determine cause to handle the situation. Two capabilities that allow a PMI service routine to improve branch tracing and performance monitoring are:

- **Freezing LBRs on PMI (bit 11)**— The processor freezes LBRs on a PMI request by clearing the LBR bit (bit 0) in IA32\_DEBUGCTL. Software must then re-enable IA32\_DEBUGCTL.[0] to continue monitoring branches. When using this feature, software should be careful about writes to IA32\_DEBUGCTL to avoid re-enabling LBRs by accident if they were just disabled.
- **Freezing PMCs on PMI (bit 12)** — The processor freezes the performance counters on a PMI request by clearing the MSR\_PERF\_GLOBAL\_CTRL MSR (see Figure 18-3). The PMCs affected include both general-purpose counters and

fixed-function counters (see Section 18.4.1, “Fixed-function Performance Counters”). Software must re-enable counts by writing 1s to the corresponding enable bits in MSR\_PERF\_GLOBAL\_CTRL before leaving a PMI service routine to continue counter operation.

Freezing LBRs and PMCs on PMIs occur when:

- A performance counter had an overflow and was programmed to signal a PMI in case of an overflow.
  - For the general-purpose counters; this is done by setting bit 20 of the IA32\_PERFEVTSELx register.
  - For the fixed-function counters; this is done by setting the 3rd bit in the corresponding 4-bit control field of the MSR\_PERF\_FIXED\_CTR\_CTRL register (see Figure 18-1) or IA32\_FIXED\_CTR\_CTRL MSR (see Figure 18-2).
- The PEBS buffer is almost full and reaches the interrupt threshold.
- The BTS buffer is almost full and reaches the interrupt threshold.

### 17.4.8 LBR Stack

The last branch record stack and top-of-stack (TOS) pointer MSRs are supported across Intel 64 and IA-32 processor families. However, the number of MSRs in the LBR stack and the valid range of TOS pointer value can vary between different processor families. Table 17-3 lists the LBR stack size and TOS pointer range for several processor families according to the CPUID signatures of DisplayFamily\_DisplayModel encoding (see CPUID instruction in Chapter 3 of *Intel® 64 and IA-32 Architectures Software Developer’s Manual, Volume 2A*).

**Table 17-3. LBR Stack Size and TOS Pointer Range**

DisplayFamily_DisplayModel	Size of LBR Stack	Range of TOS Pointer
06_2AH	16	0 to 15
06_1AH, 06_1EH, 06_1FH, 06_2EH, 06_25H, 06_2CH	16	0 to 15
06_17H, 06_1DH	4	0 to 3
06_0FH	4	0 to 3
06_1CH	8	0 to 7

The last branch recording mechanism tracks not only branch instructions (like JMP, Jcc, LOOP and CALL instructions), but also other operations that cause a change in the instruction pointer (like external interrupts, traps and faults). The branch recording mechanisms generally employs a set of MSRs, referred to as last branch record (LBR) stack. The size and exact locations of the LBR stack are generally

model-specific (see Chapter 34, “Model-Specific Registers (MSRs)” of *Intel® 64 and IA-32 Architectures Software Developer’s Manual, Volume 3C* for model-specific MSR addresses).

- **Last Branch Record (LBR) Stack** — The LBR consists of N pairs of MSRs (N is listed in the LBR stack size column of Table 17-3) that store source and destination address of recent branches (see Figure 17-3):
  - MSR\_LASTBRANCH\_0\_FROM\_IP (address is model specific) through the next consecutive (N-1) MSR address store source addresses
  - MSR\_LASTBRANCH\_0\_TO\_IP (address is model specific ) through the next consecutive (N-1) MSR address store destination addresses.
- **Last Branch Record Top-of-Stack (TOS) Pointer** — The lowest significant M bits of the TOS Pointer MSR (MSR\_LASTBRANCH\_TOS, address is model specific) contains an M-bit pointer to the MSR in the LBR stack that contains the most recent branch, interrupt, or exception recorded. The valid range of the M-bit POS pointer is given in Table 17-3.

### 17.4.8.1 LBR Stack and Intel® 64 Processors

LBR MSRs are 64-bits. If IA-32e mode is disabled, only the lower 32-bits of the address is recorded. If IA-32e mode is enabled, the processor writes 64-bit values into the MSR.

In 64-bit mode, last branch records store 64-bit addresses; in compatibility mode, the upper 32-bits of last branch records are cleared.

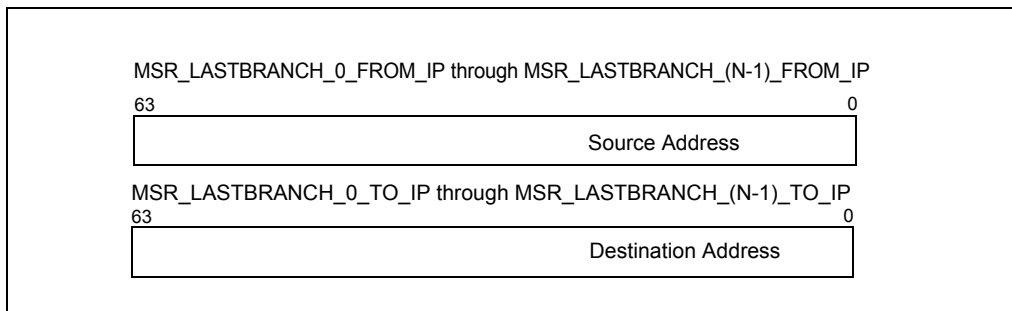


Figure 17-4. 64-bit Address Layout of LBR MSR

Software should query an architectural MSR IA32\_PERF\_CAPABILITIES[5:0] about the format of the address that is stored in the LBR stack. Four formats are defined by the following encoding:

- **00000B (32-bit record format)** — Stores 32-bit offset in current CS of respective source/destination,



- **000001B (64-bit LIP record format)** — Stores 64-bit linear address of respective source/destination,
- **000010B (64-bit EIP record format)** — Stores 64-bit offset (effective address) of respective source/destination.
- **000011B (64-bit EIP record format) and Flags** — Stores 64-bit offset (effective address) of respective source/destination. LBR flags are supported in the upper bits of 'FROM' register in the LBR stack. See LBR stack details below for flag support and definition.

Processor's support for the architectural MSR IA32\_PERF\_CAPABILITIES is provided by CPUID.01H:ECX[PERF\_CAPAB\_MSR] (bit 15).

### 17.4.8.2 LBR Stack and IA-32 Processors

The LBR MSRs in IA-32 processors introduced prior to Intel 64 architecture store the 32-bit "To Linear Address" and "From Linear Address" using the high and low half of each 64-bit MSR.

### 17.4.8.3 Last Exception Records and Intel 64 Architecture

Intel 64 and IA-32 processors also provide MSRs that store the branch record for the last branch taken prior to an exception or an interrupt. The location of the last exception record (LER) MSRs are model specific. The MSRs that store last exception records are 64-bits. If IA-32e mode is disabled, only the lower 32-bits of the address is recorded. If IA-32e mode is enabled, the processor writes 64-bit values into the MSR. In 64-bit mode, last exception records store 64-bit addresses; in compatibility mode, the upper 32-bits of last exception records are cleared.

### 17.4.9 BTS and DS Save Area

The **Debug store (DS)** feature flag (bit 21), returned by CPUID.1:EDX[21] Indicates that the processor provides the debug store (DS) mechanism. This mechanism allows BTMs to be stored in a memory-resident BTS buffer. See Section 17.4.5, "Branch Trace Store (BTS)." Precise event-based sampling (PEBS, see Section 18.4.4, "Precise Event Based Sampling (PEBS),") also uses the DS save area provided by debug store mechanism. When CPUID.1:EDX[21] is set, the following BTS facilities are available:

- The BTS\_UNAVAILABLE flag in the IA32\_MISC\_ENABLE MSR indicates (when clear) the availability of the BTS facilities, including the ability to set the BTS and BTINT bits in the MSR\_DEBUGCTLA MSR.
- The IA32\_DS\_AREA MSR can be programmed to point to the DS save area.

The debug store (DS) save area is a software-designated area of memory that is used to collect the following two types of information:

- **Branch records** — When the BTS flag in the IA32\_DEBUGCTL MSR is set, a branch record is stored in the BTS buffer in the DS save area whenever a taken branch, interrupt, or exception is detected.
- **PEBS records** — When a performance counter is configured for PEBS, a PEBS record is stored in the PEBS buffer in the DS save area after the counter overflow occurs. This record contains the architectural state of the processor (state of the 8 general purpose registers, EIP register, and EFLAGS register) at the next occurrence of the PEBS event that caused the counter to overflow. When the state information has been logged, the counter is automatically reset to a preselected value, and event counting begins again.

### NOTE

On processors based on Intel Core microarchitecture and for Intel Atom processor family, PEBS is supported only for a subset of the performance events.

### NOTES

DS save area and recording mechanism is not available in the SMM. The feature is disabled on transition to the SMM mode. Similarly DS recording is disabled on the generation of a machine check exception and is cleared on processor RESET and INIT. DS recording is available in real address mode.

The BTS and PEBS facilities may not be available on all processors. The availability of these facilities is indicated by the BTS\_UNAVAILABLE and PEBS\_UNAVAILABLE flags, respectively, in the IA32\_MISC\_ENABLE MSR (see Chapter 34).

The DS save area is divided into three parts (see Figure 17-5): buffer management area, branch trace store (BTS) buffer, and PEBS buffer. The buffer management area is used to define the location and size of the BTS and PEBS buffers. The processor then uses the buffer management area to keep track of the branch and/or PEBS records in their respective buffers and to record the performance counter reset value. The linear address of the first byte of the DS buffer management area is specified with the IA32\_DS\_AREA MSR.

The fields in the buffer management area are as follows:

- **BTS buffer base** — Linear address of the first byte of the BTS buffer. This address should point to a natural doubleword boundary.
- **BTS index** — Linear address of the first byte of the next BTS record to be written to. Initially, this address should be the same as the address in the BTS buffer base field.
- **BTS absolute maximum** — Linear address of the next byte past the end of the BTS buffer. This address should be a multiple of the BTS record size (12 bytes) plus 1.

- **BTS interrupt threshold** — Linear address of the BTS record on which an interrupt is to be generated. This address must point to an offset from the BTS buffer base that is a multiple of the BTS record size. Also, it must be several records short of the BTS absolute maximum address to allow a pending interrupt to be handled prior to processor writing the BTS absolute maximum record.
- **PEBS buffer base** — Linear address of the first byte of the PEBS buffer. This address should point to a natural doubleword boundary.
- **PEBS index** — Linear address of the first byte of the next PEBS record to be written to. Initially, this address should be the same as the address in the PEBS buffer base field.

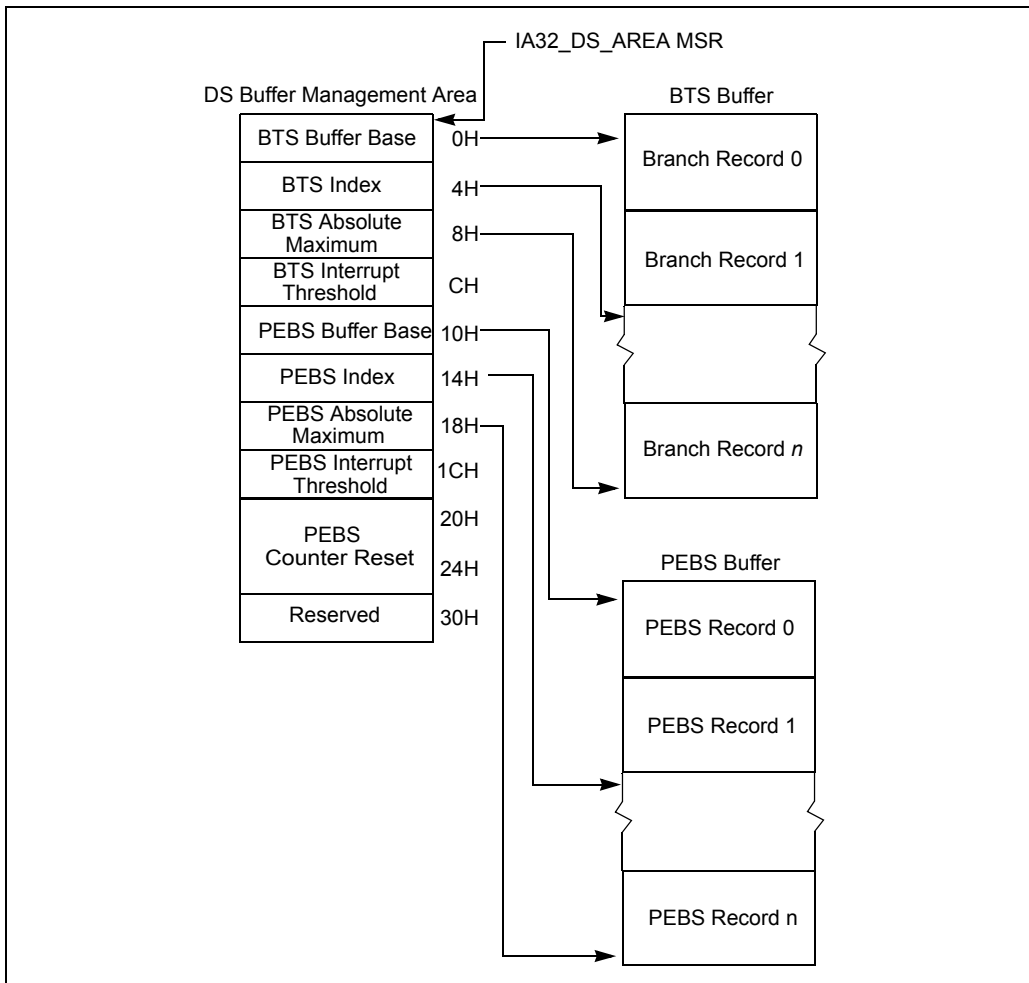
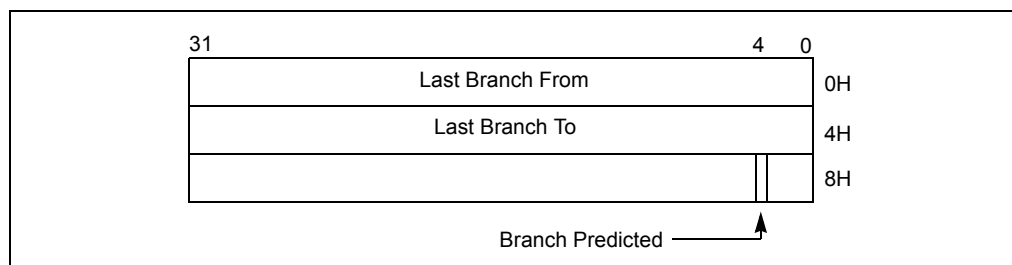


Figure 17-5. DS Save Area

- **PEBS absolute maximum** — Linear address of the next byte past the end of the PEBS buffer. This address should be a multiple of the PEBS record size (40 bytes) plus 1.
- **PEBS interrupt threshold** — Linear address of the PEBS record on which an interrupt is to be generated. This address must point to an offset from the PEBS buffer base that is a multiple of the PEBS record size. Also, it must be several records short of the PEBS absolute maximum address to allow a pending interrupt to be handled prior to processor writing the PEBS absolute maximum record.
- **PEBS counter reset value** — A 40-bit value that the counter is to be reset to after state information has collected following counter overflow. This value allows state information to be collected after a preset number of events have been counted.

Figure 17-6 shows the structure of a 12-byte branch record in the BTS buffer. The fields in each record are as follows:

- **Last branch from** — Linear address of the instruction from which the branch, interrupt, or exception was taken.
- **Last branch to** — Linear address of the branch target or the first instruction in the interrupt or exception service routine.
- **Branch predicted** — Bit 4 of field indicates whether the branch that was taken was predicted (set) or not predicted (clear).



**Figure 17-6. 32-bit Branch Trace Record Format**

Figure 17-7 shows the structure of the 40-byte PEBS records. Nominally the register values are those at the beginning of the instruction that caused the event. However, there are cases where the registers may be logged in a partially modified state. The linear IP field shows the value in the EIP register translated from an offset into the current code segment to a linear address.

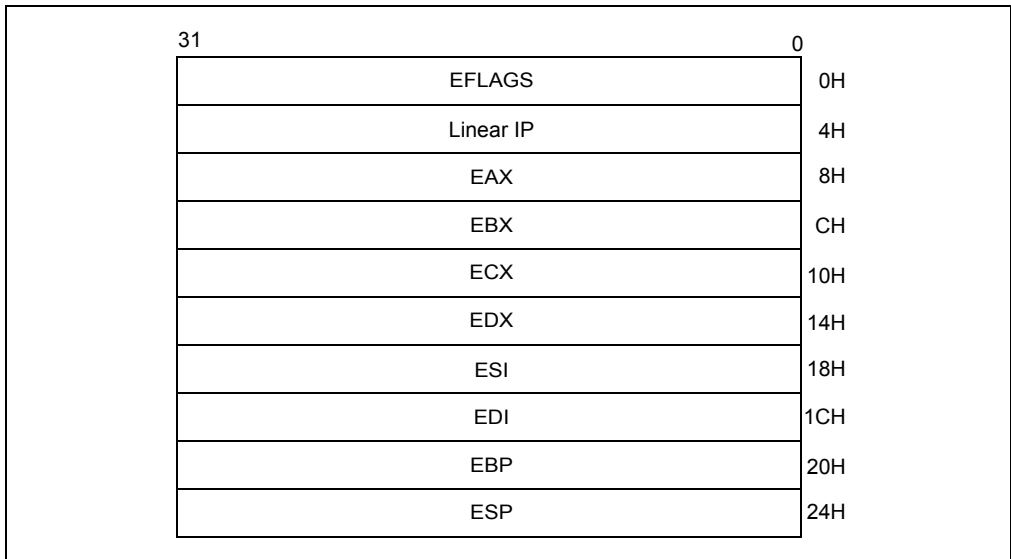
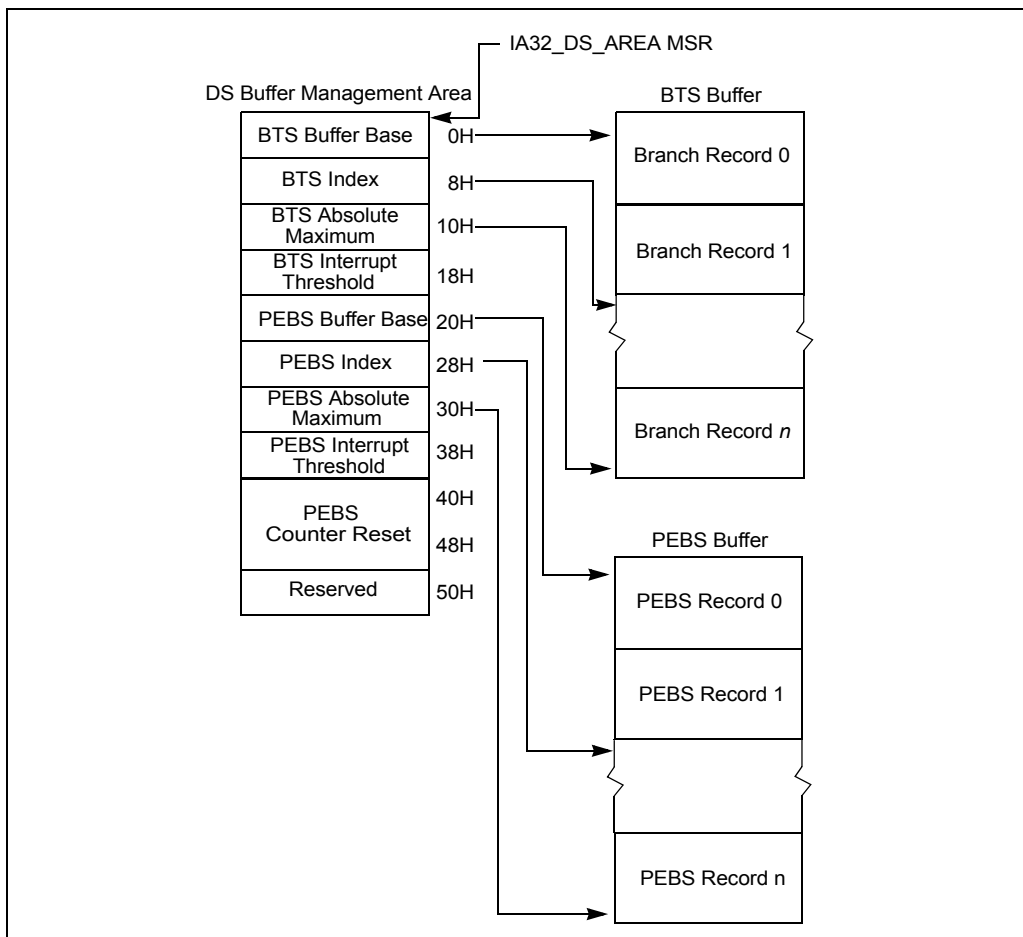


Figure 17-7. PEBS Record Format

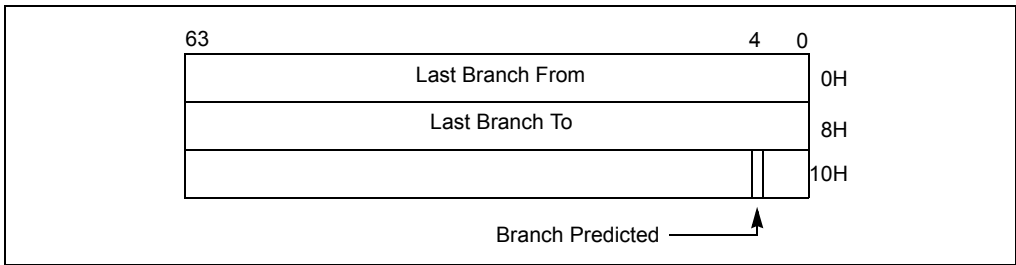
### 17.4.9.1 DS Save Area and IA-32e Mode Operation

When IA-32e mode is active (IA32\_EFER.LMA = 1), the structure of the DS save area is shown in Figure 17-8. The organization of each field in IA-32e mode operation is similar to that of non-IA-32e mode operation. However, each field now stores a 64-bit address. The IA32\_DS\_AREA MSR holds the 64-bit linear address of the first byte of the DS buffer management area.

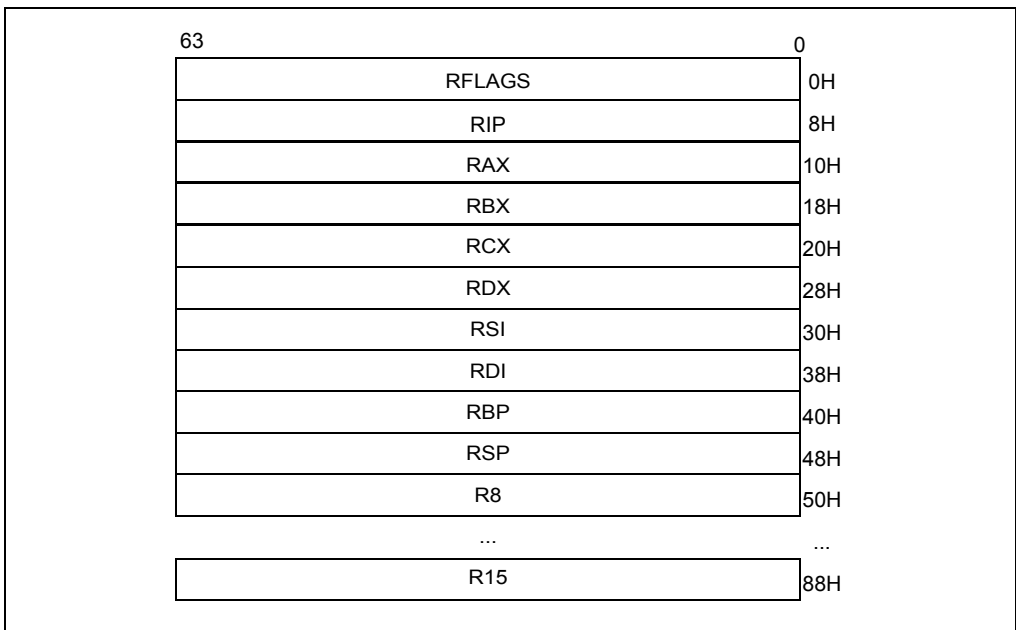


**Figure 17-8. IA-32e Mode DS Save Area**

When IA-32e mode is active, the structure of a branch trace record is similar to that shown in Figure 17-6, but each field is 8 bytes in length. This makes each BTS record 24 bytes (see Figure 17-9). The structure of a PEBS record is similar to that shown in Figure 17-7, but each field is 8 bytes in length and architectural states include register R8 through R15. This makes the size of a PEBS record in 64-bit mode 144 bytes (see Figure 17-10).



**Figure 17-9. 64-bit Branch Trace Record Format**



**Figure 17-10. 64-bit PEBS Record Format**

Fields in the buffer management area of a DS save area are described in Section 17.4.9.

The format of a branch trace record and a PEBS record are the same as the 64-bit record formats shown in Figures 17-9 and Figures 17-10, with the exception that the branch predicted bit is not supported by Intel Core microarchitecture or Intel Atom microarchitecture. The 64-bit record formats for BTS and PEBS apply to DS save area for all operating modes.

The procedures used to program IA32\_DEBUG\_CTRL MSR to set up a BTS buffer or a CPL-qualified BTS are described in Section 17.4.9.3 and Section 17.4.9.4.

Required elements for writing a DS interrupt service routine are largely the same on processors that support using DS Save area for BTS or PEBS records. However, on processors based on Intel NetBurst® microarchitecture, re-enabling counting requires writing to CCCRs. But a DS interrupt service routine on processors based on Intel Core or Intel Atom microarchitecture should:

- Re-enable the enable bits in IA32\_PERF\_GLOBAL\_CTRL MSR if it is servicing an overflow PMI due to PEBS.
- Clear overflow indications by writing to IA32\_PERF\_GLOBAL\_OVF\_CTRL when a counting configuration is changed. This includes bit 62 (ClrOvfBuffer) and the overflow indication of counters used in either PEBS or general-purpose counting (specifically: bits 0 or 1; see Figures 18-3).

### 17.4.9.2 Setting Up the DS Save Area

To save branch records with the BTS buffer, the DS save area must first be set up in memory as described in the following procedure (See Section 18.4.4.1, "Setting up the PEBS Buffer," for instructions for setting up a PEBS buffer, respectively, in the DS save area):

1. Create the DS buffer management information area in memory (see Section 17.4.9, "BTS and DS Save Area," and Section 17.4.9.1, "DS Save Area and IA-32e Mode Operation"). Also see the additional notes in this section.
2. Write the base linear address of the DS buffer management area into the IA32\_DS\_AREA MSR.
3. Set up the performance counter entry in the xAPIC LVT for fixed delivery and edge sensitive. See Section 10.5.1, "Local Vector Table."
4. Establish an interrupt handler in the IDT for the vector associated with the performance counter entry in the xAPIC LVT.
5. Write an interrupt service routine to handle the interrupt. See Section 17.4.9.5, "Writing the DS Interrupt Service Routine."

The following restrictions should be applied to the DS save area.

- The three DS save area sections should be allocated from a non-paged pool, and marked accessed and dirty. It is the responsibility of the operating system to keep the pages that contain the buffer present and to mark them accessed and dirty. The implication is that the operating system cannot do "lazy" page-table entry propagation for these pages.
- The DS save area can be larger than a page, but the pages must be mapped to contiguous linear addresses. The buffer may share a page, so it need not be aligned on a 4-KByte boundary. For performance reasons, the base of the buffer must be aligned on a doubleword boundary and should be aligned on a cache line boundary.



- It is recommended that the buffer size for the BTS buffer and the PEBS buffer be an integer multiple of the corresponding record sizes.
- The precise event records buffer should be large enough to hold the number of precise event records that can occur while waiting for the interrupt to be serviced.
- The DS save area should be in kernel space. It must not be on the same page as code, to avoid triggering self-modifying code actions.
- There are no memory type restrictions on the buffers, although it is recommended that the buffers be designated as WB memory type for performance considerations.
- Either the system must be prevented from entering A20M mode while DS save area is active, or bit 20 of all addresses within buffer bounds must be 0.
- Pages that contain buffers must be mapped to the same physical addresses for all processes, such that any change to control register CR3 will not change the DS addresses.
- The DS save area is expected to be used only on systems with an enabled APIC. The LVT Performance Counter entry in the APCI must be initialized to use an interrupt gate instead of the trap gate.

### 17.4.9.3 Setting Up the BTS Buffer

Three flags in the MSR\_DEBUGCTLA MSR (see Table 17-4), IA32\_DEBUGCTL (see Figure 17-3), or MSR\_DEBUGCTLB (see Figure 17-16) control the generation of branch records and storing of them in the BTS buffer; these are TR, BTS, and BTINT. The TR flag enables the generation of BTMs. The BTS flag determines whether the BTMs are sent out on the system bus (clear) or stored in the BTS buffer (set). BTMs cannot be simultaneously sent to the system bus and logged in the BTS buffer. The BTINT flag enables the generation of an interrupt when the BTS buffer is full. When this flag is clear, the BTS buffer is a circular buffer.

**Table 17-4. IA32\_DEBUGCTL Flag Encodings**

TR	BTS	BTINT	Description
0	X	X	Branch trace messages (BTMs) off
1	0	X	Generate BTMs
1	1	0	Store BTMs in the BTS buffer, used here as a circular buffer
1	1	1	Store BTMs in the BTS buffer, and generate an interrupt when the buffer is nearly full

The following procedure describes how to set up a DS Save area to collect branch records in the BTS buffer:

1. Place values in the BTS buffer base, BTS index, BTS absolute maximum, and BTS interrupt threshold fields of the DS buffer management area to set up the BTS buffer in memory.

2. Set the TR and BTS flags in the IA32\_DEBUGCTL for Intel Core Solo and Intel Core Duo processors or later processors (or MSR\_DEBUGCTLA MSR for processors based on Intel NetBurst Microarchitecture; or MSR\_DEBUGCTLB for Pentium M processors).
3. Clear the BTINT flag in the corresponding IA32\_DEBUGCTL (or MSR\_DEBUGCTLA MSR; or MSR\_DEBUGCTLB) if a circular BTS buffer is desired.

### NOTES

If the buffer size is set to less than the minimum allowable value (i.e.  $BTS\ absolute\ maximum < 1 + size\ of\ BTS\ record$ ), the results of BTS is undefined.

In order to prevent generating an interrupt, when working with circular BTS buffer, SW need to set BTS interrupt threshold to a value greater than BTS absolute maximum (fields of the DS buffer management area). It's not enough to clear the BTINT flag itself only.

#### 17.4.9.4 Setting Up CPL-Qualified BTS

If the processor supports CPL-qualified last branch recording mechanism, the generation of branch records and storing of them in the BTS buffer are determined by: TR, BTS, BTS\_OFF\_OS, BTS\_OFF\_USR, and BTINT. The encoding of these five bits are shown in Table 17-5.

**Table 17-5. CPL-Qualified Branch Trace Store Encodings**

TR	BTS	BTS_OFF_OS	BTS_OFF_USR	BTINT	Description
0	X	X	X	X	Branch trace messages (BTMs) off
1	0	X	X	X	Generates BTMs but do not store BTMs
1	1	0	0	0	Store all BTMs in the BTS buffer, used here as a circular buffer
1	1	1	0	0	Store BTMs with CPL > 0 in the BTS buffer
1	1	0	1	0	Store BTMs with CPL = 0 in the BTS buffer
1	1	1	1	X	Generate BTMs but do not store BTMs
1	1	0	0	1	Store all BTMs in the BTS buffer; generate an interrupt when the buffer is nearly full

**Table 17-5. CPL-Qualified Branch Trace Store Encodings (Contd.)**

TR	BTS	BTS_OFF_OS	BTS_OFF_USR	BTINT	Description
1	1	1	0	1	Store BTMs with CPL > 0 in the BTS buffer; generate an interrupt when the buffer is nearly full
1	1	0	1	1	Store BTMs with CPL = 0 in the BTS buffer; generate an interrupt when the buffer is nearly full

### 17.4.9.5 Writing the DS Interrupt Service Routine

The BTS, non-precise event-based sampling, and PEBS facilities share the same interrupt vector and interrupt service routine (called the debug store interrupt service routine or DS ISR). To handle BTS, non-precise event-based sampling, and PEBS interrupts: separate handler routines must be included in the DS ISR. Use the following guidelines when writing a DS ISR to handle BTS, non-precise event-based sampling, and/or PEBS interrupts.

- The DS interrupt service routine (ISR) must be part of a kernel driver and operate at a current privilege level of 0 to secure the buffer storage area.
- Because the BTS, non-precise event-based sampling, and PEBS facilities share the same interrupt vector, the DS ISR must check for all the possible causes of interrupts from these facilities and pass control on to the appropriate handler.

BTS and PEBS buffer overflow would be the sources of the interrupt if the buffer index matches/exceeds the interrupt threshold specified. Detection of non-precise event-based sampling as the source of the interrupt is accomplished by checking for counter overflow.

- There must be separate save areas, buffers, and state for each processor in an MP system.
- Upon entering the ISR, branch trace messages and PEBS should be disabled to prevent race conditions during access to the DS save area. This is done by clearing TR flag in the IA32\_DEBUGCTL (or MSR\_DEBUGCTLA MSR) and by clearing the precise event enable flag in the MSR\_PEBS\_ENABLE MSR. These settings should be restored to their original values when exiting the ISR.
- The processor will not disable the DS save area when the buffer is full and the circular mode has not been selected. The current DS setting must be retained and restored by the ISR on exit.
- After reading the data in the appropriate buffer, up to but not including the current index into the buffer, the ISR must reset the buffer index to the beginning of the buffer. Otherwise, everything up to the index will look like new entries upon the next invocation of the ISR.

- The ISR must clear the mask bit in the performance counter LVT entry.
- The ISR must re-enable the counters to count via IA32\_PERF\_GLOBAL\_CTRL/IA32\_PERF\_GLOBAL\_OVF\_CTRL if it is servicing an overflow PMI due to PEBS (or via CCCR's ENABLE bit on processor based on Intel NetBurst microarchitecture).
- The Pentium 4 Processor and Intel Xeon Processor mask PMIs upon receiving an interrupt. Clear this condition before leaving the interrupt handler.

## 17.5 LAST BRANCH, INTERRUPT, AND EXCEPTION RECORDING (INTEL® CORE™ 2 DUO AND INTEL® ATOM™ PROCESSOR FAMILY)

The Intel Core 2 Duo processor family and Intel Xeon processors based on Intel Core microarchitecture or enhanced Intel Core microarchitecture provide last branch interrupt and exception recording. The facilities described in this section also apply to Intel Atom processor family. These capabilities are similar to those found in Pentium 4 processors, including support for the following facilities:

- **Debug Trace and Branch Recording Control** — The IA32\_DEBUGCTL MSR provide bit fields for software to configure mechanisms related to debug trace, branch recording, branch trace store, and performance counter operations. See Section 17.4.1 for a description of the flags. See Figure 17-3 for the MSR layout.
- **Last branch record (LBR) stack** — There are a collection of MSR pairs that store the source and destination addresses related to recently executed branches. See Section 17.5.1.
- **Monitoring and single-stepping of branches, exceptions, and interrupts**
  - See Section 17.4.2 and Section 17.4.3. In addition, the ability to freeze the LBR stack on a PMI request is available.
  - The Intel Atom processor family clears the TR flag when the FREEZE\_LBRS\_ON\_PMI flag is set.
- **Branch trace messages** — See Section 17.4.4.
- **Last exception records** — See Section 17.8.3.
- **Branch trace store and CPL-qualified BTS** — See Section 17.4.5.
- **FREEZE\_LBRS\_ON\_PMI flag (bit 11)** — see Section 17.4.7.
- **FREEZE\_PERFMON\_ON\_PMI flag (bit 12)** — see Section 17.4.7.
- **FREEZE\_WHILE\_SMM\_EN (bit 14)** — FREEZE\_WHILE\_SMM\_EN is supported if IA32\_PERF\_CAPABILITIES.FREEZE\_WHILE\_SMM[Bit 12] is reporting 1. See Section 17.4.1.

## 17.5.1 LBR Stack

The last branch record stack and top-of-stack (TOS) pointer MSRs are supported across Intel Core 2, Intel Xeon and Intel Atom processor families.

Four pairs of MSRs are supported in the LBR stack for Intel Core 2 and Intel Xeon processor families:

- **Last Branch Record (LBR) Stack**
  - MSR\_LASTBRANCH\_0\_FROM\_IP (address 40H) through MSR\_LASTBRANCH\_3\_FROM\_IP (address 43H) store source addresses
  - MSR\_LASTBRANCH\_0\_TO\_IP (address 60H) through MSR\_LASTBRANCH\_3\_TO\_IP (address 63H) store destination addresses
- **Last Branch Record Top-of-Stack (TOS) Pointer** — The lowest significant 2 bits of the TOS Pointer MSR (MSR\_LASTBRANCH\_TOS, address 1C9H) contains a pointer to the MSR in the LBR stack that contains the most recent branch, interrupt, or exception recorded.

Eight pairs of MSRs are supported in the LBR stack for Intel Atom processors:

- **Last Branch Record (LBR) Stack**
  - MSR\_LASTBRANCH\_0\_FROM\_IP (address 40H) through MSR\_LASTBRANCH\_7\_FROM\_IP (address 47H) store source addresses
  - MSR\_LASTBRANCH\_0\_TO\_IP (address 60H) through MSR\_LASTBRANCH\_7\_TO\_IP (address 67H) store destination addresses
- **Last Branch Record Top-of-Stack (TOS) Pointer** — The lowest significant 3 bits of the TOS Pointer MSR (MSR\_LASTBRANCH\_TOS, address 1C9H) contains a pointer to the MSR in the LBR stack that contains the most recent branch, interrupt, or exception recorded.

For compatibility, the MSR\_LER\_TO\_LIP and the MSR\_LER\_FROM\_LIP MSRs) duplicate functions of the LastExceptionToIP and LastExceptionFromIP MSRs found in P6 family processors.

## 17.6 LAST BRANCH, INTERRUPT, AND EXCEPTION RECORDING FOR PROCESSORS BASED ON INTEL® MICROARCHITECTURE CODE NAME NEHALEM

The processors based on Intel® microarchitecture code name Nehalem and Intel® microarchitecture code name Westmere support last branch interrupt and exception recording. These capabilities are similar to those found in Intel Core 2 processors and adds additional capabilities:

- **Debug Trace and Branch Recording Control** — The IA32\_DEBUGCTL MSR provides bit fields for software to configure mechanisms related to debug trace,

branch recording, branch trace store, and performance counter operations. See Section 17.4.1 for a description of the flags. See Figure 17-11 for the MSR layout.

- **Last branch record (LBR) stack** — There are 16 MSR pairs that store the source and destination addresses related to recently executed branches. See Section 17.6.1.
- **Monitoring and single-stepping of branches, exceptions, and interrupts** — See Section 17.4.2 and Section 17.4.3. In addition, the ability to freeze the LBR stack on a PMI request is available.
- **Branch trace messages** — The IA32\_DEBUGCTL MSR provides bit fields for software to enable each logical processor to generate branch trace messages. See Section 17.4.4. However, not all BTM messages are observable using the Intel® QPI link.
- **Last exception records** — See Section 17.8.3.
- **Branch trace store and CPL-qualified BTS** — See Section 17.4.6 and Section 17.4.5.
- **FREEZE\_LBRS\_ON\_PMI flag (bit 11)** — see Section 17.4.7.
- **FREEZE\_PERFMON\_ON\_PMI flag (bit 12)** — see Section 17.4.7.
- **UNCORE\_PMI\_EN (bit 13)** — When set, this logical processor is enabled to receive an counter overflow interrupt form the uncore.
- **FREEZE\_WHILE\_SMM\_EN (bit 14)** — FREEZE\_WHILE\_SMM\_EN is supported if IA32\_PERF\_CAPABILITIES.FREEZE\_WHILE\_SMM[Bit 12] is reporting 1. See Section 17.4.1.

Processors based on Intel microarchitecture code name Nehalem provide additional capabilities:

- **Independent control of uncore PMI** — The IA32\_DEBUGCTL MSR provides a bit field (see Figure 17-11) for software to enable each logical processor to receive an uncore counter overflow interrupt.
- **LBR filtering** — Processors based on Intel microarchitecture code name Nehalem support filtering of LBR based on combination of CPL and branch type conditions. When LBR filtering is enabled, the LBR stack only captures the subset of branches that are specified by MSR\_LBR\_SELECT.

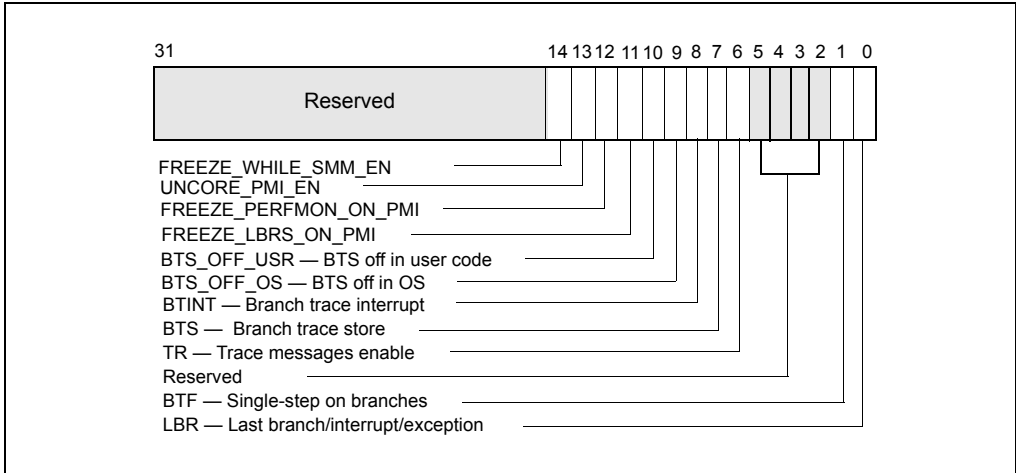


Figure 17-11. IA32\_DEBUGCTL MSR for Processors based on Intel microarchitecture code name Nehalem

### 17.6.1 LBR Stack

Processors based on Intel microarchitecture code name Nehalem provide 16 pairs of MSR to record last branch record information. The layout of each MSR pair is shown in Table 17-6 and Table 17-7.

Table 17-6. IA32\_LASTBRANCH\_x\_FROM\_IP

Bit Field	Bit Offset	Access	Description
Data	47:0	R/O	The linear address of the branch instruction itself, this is the “branch from” address.
SIGN_EXT	62:48	R/O	Signed extension of bit 47 of this register.
MISPRED	63	R/O	When set, indicates either the target of the branch was mispredicted and/or the direction (taken/non-taken) was mispredicted; otherwise, the target branch was predicted.

Table 17-7. IA32\_LASTBRANCH\_x\_TO\_IP

Bit Field	Bit Offset	Access	Description
Data	47:0	R/O	The linear address of the target of the branch instruction itself, this is the “branch to” address.

**Table 17-7. IA32\_LASTBRANCH\_x\_TO\_IP (Contd.)**

Bit Field	Bit Offset	Access	Description
SIGN_Ext	63:48	R/O	Signed extension of bit 47 of this register.

Processors based on Intel microarchitecture code name Nehalem have an LBR MSR Stack as shown in Table 17-8.

**Table 17-8. LBR Stack Size and TOS Pointer Range**

DisplayFamily_DisplayModel	Size of LBR Stack	Range of TOS Pointer
06_1AH	16	0 to 15

## 17.6.2 Filtering of Last Branch Records

MSR\_LBR\_SELECT is cleared to zero at RESET, and LBR filtering is disabled, i.e. all branches will be captured. MSR\_LBR\_SELECT provides bit fields to specify the conditions of subsets of branches that will not be captured in the LBR. The layout of MSR\_LBR\_SELECT is shown in Table 17-9.

**Table 17-9. MSR\_LBR\_SELECT for Intel microarchitecture code name Nehalem**

Bit Field	Bit Offset	Access	Description
CPL_EQ_0	0	R/W	When set, do not capture branches occurring in ring 0
CPL_NEQ_0	1	R/W	When set, do not capture branches occurring in ring >0
JCC	2	R/W	When set, do not capture conditional branches
NEAR_REL_CALL	3	R/W	When set, do not capture near relative calls
NEAR_IND_CALL	4	R/W	When set, do not capture near indirect calls
NEAR_RET	5	R/W	When set, do not capture near returns
NEAR_IND_JMP	6	R/W	When set, do not capture near indirect jumps
NEAR_REL_JMP	7	R/W	When set, do not capture near relative jumps
FAR_BRANCH	8	R/W	When set, do not capture far branches
Reserved	63:9		Must be zero



## 17.7 LAST BRANCH, INTERRUPT, AND EXCEPTION RECORDING FOR PROCESSORS BASED ON INTEL® MICROARCHITECTURE CODE NAME SANDY BRIDGE

Generally, all of the last branch record, interrupt and exception recording facility described in Section 17.6, “Last Branch, Interrupt, and Exception Recording for Processors based on Intel® Microarchitecture code name Nehalem”, apply to processors based on Intel® microarchitecture code name Sandy Bridge.

One difference of note is that MSR\_LBR\_SELECT is shared between two logical processors in the same core. In Intel microarchitecture code name Sandy Bridge, each logical processor has its own MSR\_LBR\_SELECT. The filtering semantics for “Near\_ind\_jmp” and “Near\_rel\_jmp” has been enhanced, see Table 17-10.

**Table 17-10. MSR\_LBR\_SELECT for Intel microarchitecture code name Sandy Bridge**

Bit Field	Bit Offset	Access	Description
CPL_EQ_0	0	R/W	When set, do not capture branches occurring in ring 0
CPL_NEQ_0	1	R/W	When set, do not capture branches occurring in ring >0
JCC	2	R/W	When set, do not capture conditional branches
NEAR_REL_CALL	3	R/W	When set, do not capture near relative calls
NEAR_IND_CALL	4	R/W	When set, do not capture near indirect calls
NEAR_RET	5	R/W	When set, do not capture near returns
NEAR_IND_JMP	6	R/W	When set, do not capture near indirect jumps except near indirect calls and near returns
NEAR_REL_JMP	7	R/W	When set, do not capture near relative jumps except near relative calls.
FAR_BRANCH	8	R/W	When set, do not capture far branches
Reserved	63:9		Must be zero

## 17.8 LAST BRANCH, INTERRUPT, AND EXCEPTION RECORDING (PROCESSORS BASED ON INTEL NETBURST® MICROARCHITECTURE)

Pentium 4 and Intel Xeon processors based on Intel NetBurst microarchitecture provide the following methods for recording taken branches, interrupts and exceptions:

- Store branch records in the last branch record (LBR) stack MSR for the most recent taken branches, interrupts, and/or exceptions in MSRs. A branch record consist of a branch-from and a branch-to instruction address.
- Send the branch records out on the system bus as branch trace messages (BTMs).
- Log BTMs in a memory-resident branch trace store (BTS) buffer.

To support these functions, the processor provides the following MSRs and related facilities:

- **MSR\_DEBUGCTLA MSR** — Enables last branch, interrupt, and exception recording; single-stepping on taken branches; branch trace messages (BTMs); and branch trace store (BTS). This register is named DebugCtIMSR in the P6 family processors.
- **Debug store (DS) feature flag (CPUID.1:EDX.DS[bit 21])** — Indicates that the processor provides the debug store (DS) mechanism, which allows BTMs to be stored in a memory-resident BTS buffer.
- **CPL-qualified debug store (DS) feature flag (CPUID.1:ECX.DS-CPL[bit 4])** — Indicates that the processor provides a CPL-qualified debug store (DS) mechanism, which allows software to selectively skip sending and storing BTMs, according to specified current privilege level settings, into a memory-resident BTS buffer.
- **IA32\_MISC\_ENABLE MSR** — Indicates that the processor provides the BTS facilities.
- **Last branch record (LBR) stack** — The LBR stack is a circular stack that consists of four MSRs (MSR\_LASTBRANCH\_0 through MSR\_LASTBRANCH\_3) for the Pentium 4 and Intel Xeon processor family [CPUID family 0FH, models 0H-02H]. The LBR stack consists of 16 MSR pairs (MSR\_LASTBRANCH\_0\_FROM\_LIP through MSR\_LASTBRANCH\_15\_FROM\_LIP and MSR\_LASTBRANCH\_0\_TO\_LIP through MSR\_LASTBRANCH\_15\_TO\_LIP) for the Pentium 4 and Intel Xeon processor family [CPUID family 0FH, model 03H].
- **Last branch record top-of-stack (TOS) pointer** — The TOS Pointer MSR contains a 2-bit pointer (0-3) to the MSR in the LBR stack that contains the most recent branch, interrupt, or exception recorded for the Pentium 4 and Intel Xeon processor family [CPUID family 0FH, models 0H-02H]. This pointer becomes a 4-bit pointer (0-15) for the Pentium 4 and Intel Xeon processor family [CPUID family 0FH, model 03H]. See also: Table 17-11, Figure 17-12, and Section 17.8.2, “LBR Stack for Processors Based on Intel NetBurst<sup>®</sup> Microarchitecture.”
- **Last exception record** — See Section 17.8.3, “Last Exception Records.”

### 17.8.1 MSR\_DEBUGCTLA MSR

The MSR\_DEBUGCTLA MSR enables and disables the various last branch recording mechanisms described in the previous section. This register can be written to using the WRMSR instruction, when operating at privilege level 0 or when in real-address

mode. A protected-mode operating system procedure is required to provide user access to this register. Figure 17-12 shows the flags in the MSR\_DEBUGCTLA MSR. The functions of these flags are as follows:

- **LBR (last branch/interrupt/exception) flag (bit 0)** — When set, the processor records a running trace of the most recent branches, interrupts, and/or exceptions taken by the processor (prior to a debug exception being generated) in the last branch record (LBR) stack. Each branch, interrupt, or exception is recorded as a 64-bit branch record. The processor clears this flag whenever a debug exception is generated (for example, when an instruction or data breakpoint or a single-step trap occurs). See Section 17.8.2, “LBR Stack for Processors Based on Intel NetBurst® Microarchitecture.”
- **BTF (single-step on branches) flag (bit 1)** — When set, the processor treats the TF flag in the EFLAGS register as a “single-step on branches” flag rather than a “single-step on instructions” flag. This mechanism allows single-stepping the processor on taken branches. See Section 17.4.3, “Single-Stepping on Branches.”
- **TR (trace message enable) flag (bit 2)** — When set, branch trace messages are enabled. Thereafter, when the processor detects a taken branch, interrupt, or exception, it sends the branch record out on the system bus as a branch trace message (BTM). See Section 17.4.4, “Branch Trace Messages.”

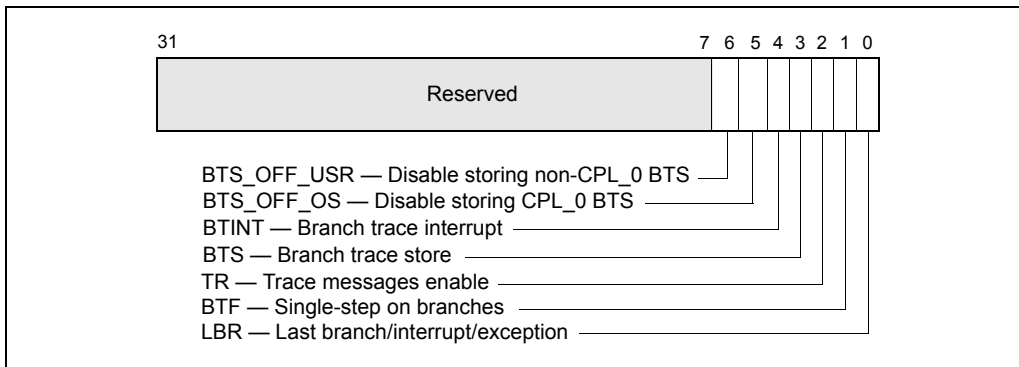


Figure 17-12. MSR\_DEBUGCTLA MSR for Pentium 4 and Intel Xeon Processors

- **BTS (branch trace store) flag (bit 3)** — When set, enables the BTS facilities to log BTMs to a memory-resident BTS buffer that is part of the DS save area. See Section 17.4.9, “BTS and DS Save Area.”
- **BTINT (branch trace interrupt) flag (bits 4)** — When set, the BTS facilities generate an interrupt when the BTS buffer is full. When clear, BTMs are logged to the BTS buffer in a circular fashion. See Section 17.4.5, “Branch Trace Store (BTS).”
- **BTS\_OFF\_OS (disable ring 0 branch trace store) flag (bit 5)** — When set, enables the BTS facilities to skip sending/logging CPL\_0 BTMs to the memory-

resident BTS buffer. See Section 17.8.2, “LBR Stack for Processors Based on Intel NetBurst® Microarchitecture.”

- **BTS\_OFF\_USR (disable ring 0 branch trace store) flag (bit 6)** — When set, enables the BTS facilities to skip sending/logging non-CPL\_0 BTMs to the memory-resident BTS buffer. See Section 17.8.2, “LBR Stack for Processors Based on Intel NetBurst® Microarchitecture.”

The initial implementation of BTS\_OFF\_USR and BTS\_OFF\_OS in MSR\_DEBUGCTLA is shown in Figure 17-12. The BTS\_OFF\_USR and BTS\_OFF\_OS fields may be implemented on other model-specific debug control register at different locations.

See Chapter 34, “Model-Specific Registers (MSRs),” for a detailed description of each of the last branch recording MSRs.

## 17.8.2 LBR Stack for Processors Based on Intel NetBurst® Microarchitecture

The LBR stack is made up of LBR MSRs that are treated by the processor as a circular stack. The TOS pointer (MSR\_LASTBRANCH\_TOS MSR) points to the LBR MSR (or LBR MSR pair) that contains the most recent (last) branch record placed on the stack. Prior to placing a new branch record on the stack, the TOS is incremented by 1. When the TOS pointer reaches its maximum value, it wraps around to 0. See Table 17-11 and Figure 17-12.

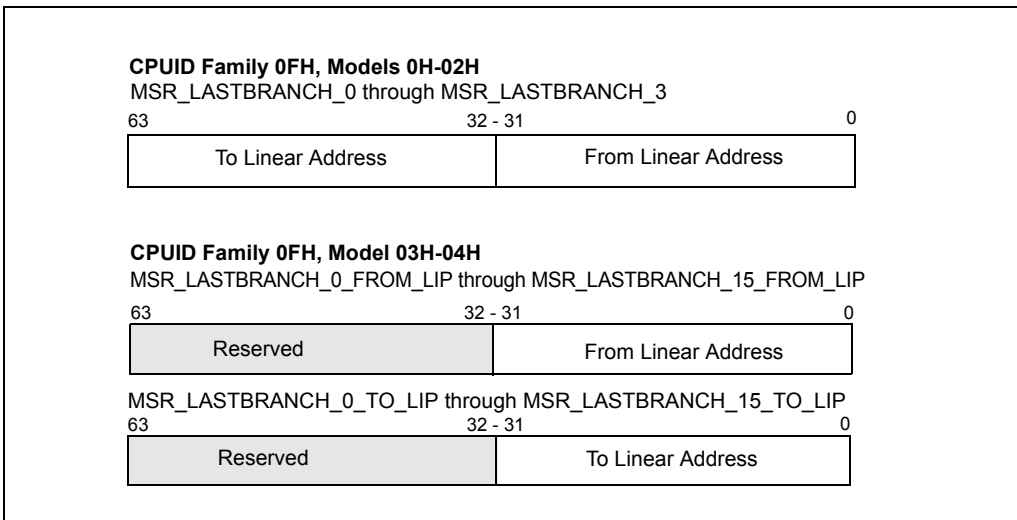
**Table 17-11. LBR MSR Stack Size and TOS Pointer Range for the Pentium® 4 and the Intel® Xeon® Processor Family**

DisplayFamily_DisplayModel	Size of LBR Stack	Range of TOS Pointer
Family 0FH, Models 0H-02H; MSRs at locations 1DBH-1DEH.	4	0 to 3
Family 0FH, Models; MSRs at locations 680H-68FH.	16	0 to 15
Family 0FH, Model 03H; MSRs at locations 6C0H-6CFH.	16	0 to 15

The registers in the LBR MSR stack and the MSR\_LASTBRANCH\_TOS MSR are read-only and can be read using the RDMSR instruction.

Figure 17-13 shows the layout of a branch record in an LBR MSR (or MSR pair). Each branch record consists of two linear addresses, which represent the “from” and “to” instruction pointers for a branch, interrupt, or exception. The contents of the from and to addresses differ, depending on the source of the branch:

- **Taken branch** — If the record is for a taken branch, the “from” address is the address of the branch instruction and the “to” address is the target instruction of the branch.
- **Interrupt** — If the record is for an interrupt, the “from” address the return instruction pointer (RIP) saved for the interrupt and the “to” address is the address of the first instruction in the interrupt handler routine. The RIP is the linear address of the next instruction to be executed upon returning from the interrupt handler.
- **Exception** — If the record is for an exception, the “from” address is the linear address of the instruction that caused the exception to be generated and the “to” address is the address of the first instruction in the exception handler routine.



**Figure 17-13. LBR MSR Branch Record Layout for the Pentium 4 and Intel Xeon Processor Family**

Additional information is saved if an exception or interrupt occurs in conjunction with a branch instruction. If a branch instruction generates a trap type exception, two branch records are stored in the LBR stack: a branch record for the branch instruction followed by a branch record for the exception.

If a branch instruction is immediately followed by an interrupt, a branch record is stored in the LBR stack for the branch instruction followed by a record for the interrupt.

### 17.8.3 Last Exception Records

The Pentium 4, Intel Xeon, Pentium M, Intel® Core™ Solo, Intel® Core™ Duo, Intel® Core™2 Duo, Intel® Core™ i7 and Intel® Atom™ processors provide two MSRs (the MSR\_LER\_TO\_LIP and the MSR\_LER\_FROM\_LIP MSRs) that duplicate the functions of the LastExceptionToIP and LastExceptionFromIP MSRs found in the P6 family processors. The MSR\_LER\_TO\_LIP and MSR\_LER\_FROM\_LIP MSRs contain a branch record for the last branch that the processor took prior to an exception or interrupt being generated.

## 17.9 LAST BRANCH, INTERRUPT, AND EXCEPTION RECORDING (INTEL® CORE™ SOLO AND INTEL® CORE™ DUO PROCESSORS)

Intel Core Solo and Intel Core Duo processors provide last branch interrupt and exception recording. This capability is almost identical to that found in Pentium 4 and Intel Xeon processors. There are differences in the stack and in some MSR names and locations.

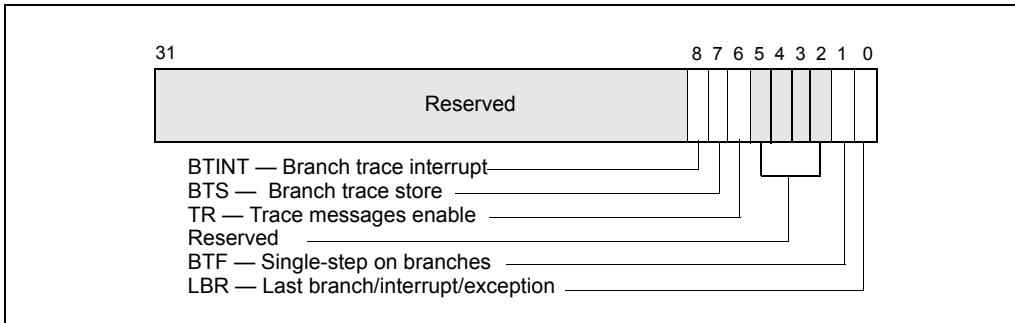
Note the following:

- **IA32\_DEBUGCTL MSR** — Enables debug trace interrupt, debug trace store, trace messages enable, performance monitoring breakpoint flags, single stepping on branches, and last branch. IA32\_DEBUGCTL MSR is located at register address 01D9H.

See Figure 17-14 for the layout and the entries below for a description of the flags:

- **LBR (last branch/interrupt/exception) flag (bit 0)** — When set, the processor records a running trace of the most recent branches, interrupts, and/or exceptions taken by the processor (prior to a debug exception being generated) in the last branch record (LBR) stack. For more information, see the “Last Branch Record (LBR) Stack” below.
- **BTF (single-step on branches) flag (bit 1)** — When set, the processor treats the TF flag in the EFLAGS register as a “single-step on branches” flag rather than a “single-step on instructions” flag. This mechanism allows single-stepping the processor on taken branches. See Section 17.4.3, “Single-Stepping on Branches,” for more information about the BTF flag.
- **TR (trace message enable) flag (bit 6)** — When set, branch trace messages are enabled. When the processor detects a taken branch, interrupt, or exception; it sends the branch record out on the system bus as a branch trace message (BTM). See Section 17.4.4, “Branch Trace Messages,” for more information about the TR flag.

- **BTS (branch trace store) flag (bit 7)** — When set, the flag enables BTS facilities to log BTMs to a memory-resident BTS buffer that is part of the DS save area. See Section 17.4.9, “BTS and DS Save Area.”
- **BTINT (branch trace interrupt) flag (bits 8)** — When set, the BTS facilities generate an interrupt when the BTS buffer is full. When clear, BTMs are logged to the BTS buffer in a circular fashion. See Section 17.4.5, “Branch Trace Store (BTS),” for a description of this mechanism.

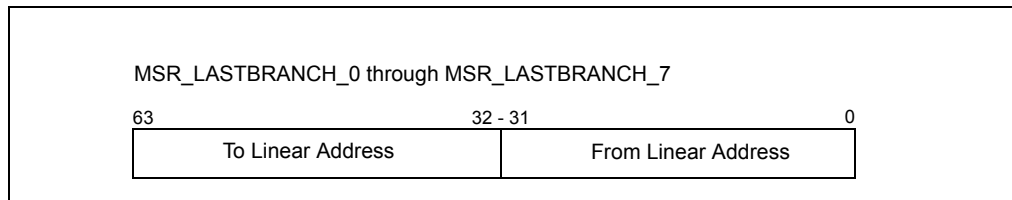


**Figure 17-14. IA32\_DEBUGCTL MSR for Intel Core Solo and Intel Core Duo Processors**

- **Debug store (DS) feature flag (bit 21), returned by the CPUID instruction** — Indicates that the processor provides the debug store (DS) mechanism, which allows BTMs to be stored in a memory-resident BTS buffer. See Section 17.4.5, “Branch Trace Store (BTS).”
- **Last Branch Record (LBR) Stack** — The LBR stack consists of 8 MSRs (MSR\_LASTBRANCH\_0 through MSR\_LASTBRANCH\_7); bits 31-0 hold the ‘from’ address, bits 63-32 hold the ‘to’ address (MSR addresses start at 40H). See Figure 17-15.
- **Last Branch Record Top-of-Stack (TOS) Pointer** — The TOS Pointer MSR contains a 3-bit pointer (bits 2-0) to the MSR in the LBR stack that contains the most recent branch, interrupt, or exception recorded. For Intel Core Solo and Intel Core Duo processors, this MSR is located at register address 01C9H.

For compatibility, the Intel Core Solo and Intel Core Duo processors provide two 32-bit MSRs (the MSR\_LER\_TO\_LIP and the MSR\_LER\_FROM\_LIP MSRs) that duplicate functions of the LastExceptionToIP and LastExceptionFromIP MSRs found in P6 family processors.

For details, see Section 17.8, “Last Branch, Interrupt, and Exception Recording (Processors based on Intel NetBurst® Microarchitecture),” and Section 34.10, “MSRs In Intel® Core™ Solo and Intel® Core™ Duo Processors”



**Figure 17-15. LBR Branch Record Layout for the Intel Core Solo and Intel Core Duo Processor**

## 17.10 LAST BRANCH, INTERRUPT, AND EXCEPTION RECORDING (PENTIUM M PROCESSORS)

Like the Pentium 4 and Intel Xeon processor family, Pentium M processors provide last branch interrupt and exception recording. The capability operates almost identically to that found in Pentium 4 and Intel Xeon processors. There are differences in the shape of the stack and in some MSR names and locations. Note the following:

- **MSR\_DEBUGCTLB MSR** — Enables debug trace interrupt, debug trace store, trace messages enable, performance monitoring breakpoint flags, single stepping on branches, and last branch. For Pentium M processors, this MSR is located at register address 01D9H. See Figure 17-16 and the entries below for a description of the flags.
  - **LBR (last branch/interrupt/exception) flag (bit 0)** — When set, the processor records a running trace of the most recent branches, interrupts, and/or exceptions taken by the processor (prior to a debug exception being generated) in the last branch record (LBR) stack. For more information, see the “Last Branch Record (LBR) Stack” bullet below.
  - **BTF (single-step on branches) flag (bit 1)** — When set, the processor treats the TF flag in the EFLAGS register as a “single-step on branches” flag rather than a “single-step on instructions” flag. This mechanism allows single-stepping the processor on taken branches. See Section 17.4.3, “Single-Stepping on Branches,” for more information about the BTF flag.
  - **PBi (performance monitoring/breakpoint pins) flags (bits 5-2)** — When these flags are set, the performance monitoring/breakpoint pins on the processor (BP0#, BP1#, BP2#, and BP3#) report breakpoint matches in the corresponding breakpoint-address registers (DR0 through DR3). The processor asserts then deasserts the corresponding BPi# pin when a breakpoint match occurs. When a PBi flag is clear, the performance monitoring/breakpoint pins report performance events. Processor execution is not affected by reporting performance events.



- **TR (trace message enable) flag (bit 6)** — When set, branch trace messages are enabled. When the processor detects a taken branch, interrupt, or exception, it sends the branch record out on the system bus as a branch trace message (BTM). See Section 17.4.4, “Branch Trace Messages,” for more information about the TR flag.
- **BTS (branch trace store) flag (bit 7)** — When set, enables the BTS facilities to log BTMs to a memory-resident BTS buffer that is part of the DS save area. See Section 17.4.9, “BTS and DS Save Area.”
- **BTINT (branch trace interrupt) flag (bits 8)** — When set, the BTS facilities generate an interrupt when the BTS buffer is full. When clear, BTMs are logged to the BTS buffer in a circular fashion. See Section 17.4.5, “Branch Trace Store (BTS),” for a description of this mechanism.

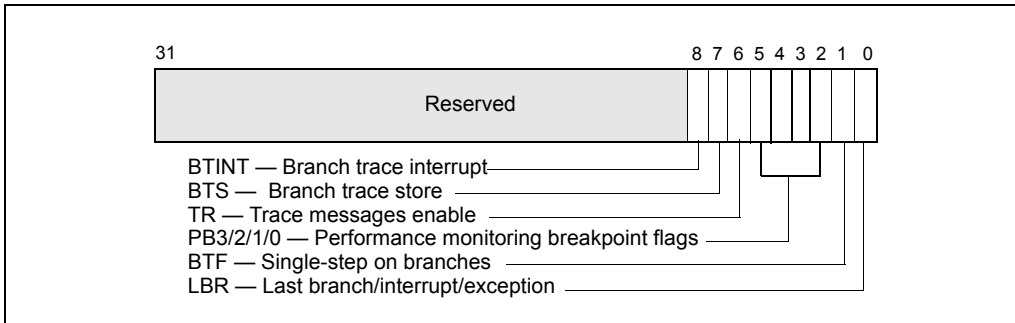


Figure 17-16. MSR\_DEBUGCTLB MSR for Pentium M Processors

- **Debug store (DS) feature flag (bit 21), returned by the CPUID instruction** — Indicates that the processor provides the debug store (DS) mechanism, which allows BTMs to be stored in a memory-resident BTS buffer. See Section 17.4.5, “Branch Trace Store (BTS).”
- **Last Branch Record (LBR) Stack** — The LBR stack consists of 8 MSRs (MSR\_LASTBRANCH\_0 through MSR\_LASTBRANCH\_7); bits 31-0 hold the ‘from’ address, bits 63-32 hold the ‘to’ address. For Pentium M Processors, these pairs are located at register addresses 040H-047H. See Figure 17-17.
- **Last Branch Record Top-of-Stack (TOS) Pointer** — The TOS Pointer MSR contains a 3-bit pointer (bits 2-0) to the MSR in the LBR stack that contains the most recent branch, interrupt, or exception recorded. For Pentium M Processors, this MSR is located at register address 01C9H.

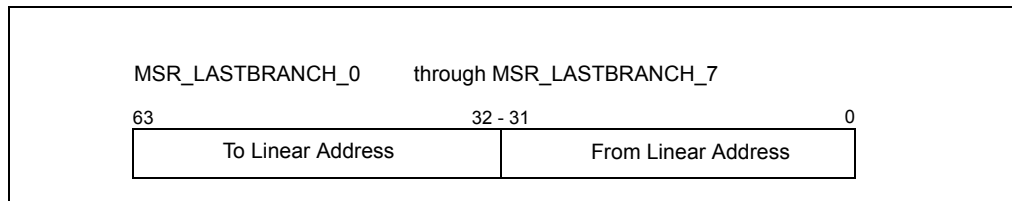


Figure 17-17. LBR Branch Record Layout for the Pentium M Processor

For more detail on these capabilities, see Section 17.8.3, “Last Exception Records,” and Section 34.11, “MSRs In the Pentium M Processor.”

## 17.11 LAST BRANCH, INTERRUPT, AND EXCEPTION RECORDING (P6 FAMILY PROCESSORS)

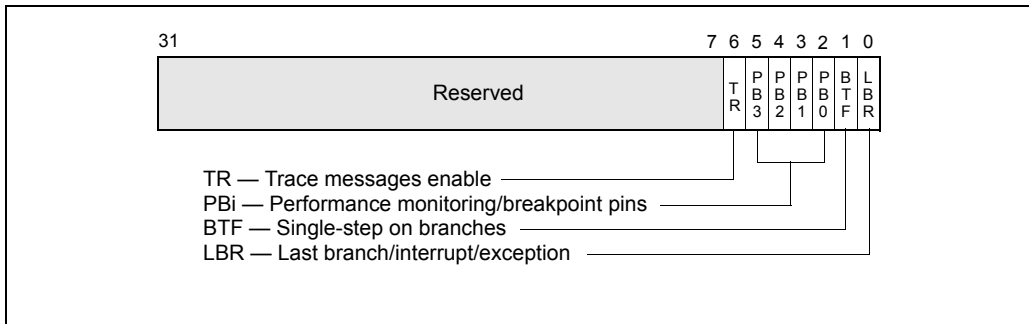
The P6 family processors provide five MSRs for recording the last branch, interrupt, or exception taken by the processor: DEBUGCTLMR, LastBranchToIP, LastBranchFromIP, LastExceptionToIP, and LastExceptionFromIP. These registers can be used to collect last branch records, to set breakpoints on branches, interrupts, and exceptions, and to single-step from one branch to the next.

See Chapter 34, “Model-Specific Registers (MSRs),” for a detailed description of each of the last branch recording MSRs.

### 17.11.1 DEBUGCTLMR Register

The version of the DEBUGCTLMR register found in the P6 family processors enables last branch, interrupt, and exception recording; taken branch breakpoints; the breakpoint reporting pins; and trace messages. This register can be written to using the WRMSR instruction, when operating at privilege level 0 or when in real-address mode. A protected-mode operating system procedure is required to provide user access to this register. Figure 17-18 shows the flags in the DEBUGCTLMR register for the P6 family processors. The functions of these flags are as follows:

- LBR (last branch/interrupt/exception) flag (bit 0)** — When set, the processor records the source and target addresses (in the LastBranchToIP, LastBranchFromIP, LastExceptionToIP, and LastExceptionFromIP MSRs) for the last branch and the last exception or interrupt taken by the processor prior to a debug exception being generated. The processor clears this flag whenever a debug exception, such as an instruction or data breakpoint or single-step trap occurs.



**Figure 17-18. DEBUGCTMSR Register (P6 Family Processors)**

- **BTF (single-step on branches) flag (bit 1)** — When set, the processor treats the TF flag in the EFLAGS register as a “single-step on branches” flag. See Section 17.4.3, “Single-Stepping on Branches.”
- **PBi (performance monitoring/breakpoint pins) flags (bits 2 through 5)** — When these flags are set, the performance monitoring/breakpoint pins on the processor (BP0#, BP1#, BP2#, and BP3#) report breakpoint matches in the corresponding breakpoint-address registers (DR0 through DR3). The processor asserts then deasserts the corresponding BPi# pin when a breakpoint match occurs. When a PBi flag is clear, the performance monitoring/breakpoint pins report performance events. Processor execution is not affected by reporting performance events.
- **TR (trace message enable) flag (bit 6)** — When set, trace messages are enabled as described in Section 17.4.4, “Branch Trace Messages.” Setting this flag greatly reduces the performance of the processor. When trace messages are enabled, the values stored in the LastBranchToIP, LastBranchFromIP, LastExceptionToIP, and LastExceptionFromIP MSRs are undefined.

### 17.11.2 Last Branch and Last Exception MSRs

The LastBranchToIP and LastBranchFromIP MSRs are 32-bit registers for recording the instruction pointers for the last branch, interrupt, or exception that the processor took prior to a debug exception being generated. When a branch occurs, the processor loads the address of the branch instruction into the LastBranchFromIP MSR and loads the target address for the branch into the LastBranchToIP MSR.

When an interrupt or exception occurs (other than a debug exception), the address of the instruction that was interrupted by the exception or interrupt is loaded into the LastBranchFromIP MSR and the address of the exception or interrupt handler that is called is loaded into the LastBranchToIP MSR.

The LastExceptionToIP and LastExceptionFromIP MSRs (also 32-bit registers) record the instruction pointers for the last branch that the processor took prior to an excep-

tion or interrupt being generated. When an exception or interrupt occurs, the contents of the LastBranchToIP and LastBranchFromIP MSRs are copied into these registers before the to and from addresses of the exception or interrupt are recorded in the LastBranchToIP and LastBranchFromIP MSRs.

These registers can be read using the RDMSR instruction.

Note that the values stored in the LastBranchToIP, LastBranchFromIP, LastExceptionToIP, and LastExceptionFromIP MSRs are offsets into the current code segment, as opposed to linear addresses, which are saved in last branch records for the Pentium 4 and Intel Xeon processors.

### 17.11.3 Monitoring Branches, Exceptions, and Interrupts

When the LBR flag in the DEBUGCTLMSR register is set, the processor automatically begins recording branches that it takes, exceptions that are generated (except for debug exceptions), and interrupts that are serviced. Each time a branch, exception, or interrupt occurs, the processor records the to and from instruction pointers in the LastBranchToIP and LastBranchFromIP MSRs. In addition, for interrupts and exceptions, the processor copies the contents of the LastBranchToIP and LastBranchFromIP MSRs into the LastExceptionToIP and LastExceptionFromIP MSRs prior to recording the to and from addresses of the interrupt or exception.

When the processor generates a debug exception (#DB), it automatically clears the LBR flag before executing the exception handler, but does not touch the last branch and last exception MSRs. The addresses for the last branch, interrupt, or exception taken are thus retained in the LastBranchToIP and LastBranchFromIP MSRs and the addresses of the last branch prior to an interrupt or exception are retained in the LastExceptionToIP, and LastExceptionFromIP MSRs.

The debugger can use the last branch, interrupt, and/or exception addresses in combination with code-segment selectors retrieved from the stack to reset breakpoints in the breakpoint-address registers (DR0 through DR3), allowing a backward trace from the manifestation of a particular bug toward its source. Because the instruction pointers recorded in the LastBranchToIP, LastBranchFromIP, LastExceptionToIP, and LastExceptionFromIP MSRs are offsets into a code segment, software must determine the segment base address of the code segment associated with the control transfer to calculate the linear address to be placed in the breakpoint-address registers. The segment base address can be determined by reading the segment selector for the code segment from the stack and using it to locate the segment descriptor for the segment in the GDT or LDT. The segment base address can then be read from the segment descriptor.

Before resuming program execution from a debug-exception handler, the handler must set the LBR flag again to re-enable last branch and last exception/interrupt recording.

## 17.12 TIME-STAMP COUNTER

The Intel 64 and IA-32 architectures (beginning with the Pentium processor) define a time-stamp counter mechanism that can be used to monitor and identify the relative time occurrence of processor events. The counter's architecture includes the following components:

- **TSC flag** — A feature bit that indicates the availability of the time-stamp counter. The counter is available in an if the function `CPUID.1:EDX.TSC[bit 4] = 1`.
- **IA32\_TIME\_STAMP\_COUNTER MSR** (called TSC MSR in P6 family and Pentium processors) — The MSR used as the counter.
- **RDTSC instruction** — An instruction used to read the time-stamp counter.
- **TSD flag** — A control register flag is used to enable or disable the time-stamp counter (enabled if `CR4.TSD[bit 2] = 1`).

The time-stamp counter (as implemented in the P6 family, Pentium, Pentium M, Pentium 4, Intel Xeon, Intel Core Solo and Intel Core Duo processors and later processors) is a 64-bit counter that is set to 0 following a RESET of the processor. Following a RESET, the counter increments even when the processor is halted by the HLT instruction or the external STPCLK# pin. Note that the assertion of the external DPSLP# pin may cause the time-stamp counter to stop.

Processor families increment the time-stamp counter differently:

- For Pentium M processors (family [06H], models [09H, 0DH]); for Pentium 4 processors, Intel Xeon processors (family [0FH], models [00H, 01H, or 02H]); and for P6 family processors: the time-stamp counter increments with every internal processor clock cycle.

The internal processor clock cycle is determined by the current core-clock to bus-clock ratio. Intel® SpeedStep® technology transitions may also impact the processor clock.

- For Pentium 4 processors, Intel Xeon processors (family [0FH], models [03H and higher]); for Intel Core Solo and Intel Core Duo processors (family [06H], model [0EH]); for the Intel Xeon processor 5100 series and Intel Core 2 Duo processors (family [06H], model [0FH]); for Intel Core 2 and Intel Xeon processors (family [06H], DisplayModel [17H]); for Intel Atom processors (family [06H], DisplayModel [1CH]): the time-stamp counter increments at a constant rate. That rate may be set by the maximum core-clock to bus-clock ratio of the processor or may be set by the maximum resolved frequency at which the processor is booted. The maximum resolved frequency may differ from the maximum qualified frequency of the processor, see Section 18.12.5 for more detail.

The specific processor configuration determines the behavior. Constant TSC behavior ensures that the duration of each clock tick is uniform and supports the use of the TSC as a wall clock timer even if the processor core changes frequency. This is the architectural behavior moving forward.

## NOTE

To determine average processor clock frequency, Intel recommends the use of EMON logic to count processor core clocks over the period of time for which the average is required. See Section 18.12, "Counting Clocks," and Chapter 19, "Performance-Monitoring Events," for more information.

The RDTSC instruction reads the time-stamp counter and is guaranteed to return a monotonically increasing unique value whenever executed, except for a 64-bit counter wraparound. Intel guarantees that the time-stamp counter will not wrap-around within 10 years after being reset. The period for counter wrap is longer for Pentium 4, Intel Xeon, P6 family, and Pentium processors.

Normally, the RDTSC instruction can be executed by programs and procedures running at any privilege level and in virtual-8086 mode. The TSD flag allows use of this instruction to be restricted to programs and procedures running at privilege level 0. A secure operating system would set the TSD flag during system initialization to disable user access to the time-stamp counter. An operating system that disables user access to the time-stamp counter should emulate the instruction through a user-accessible programming interface.

The RDTSC instruction is not serializing or ordered with other instructions. It does not necessarily wait until all previous instructions have been executed before reading the counter. Similarly, subsequent instructions may begin execution before the RDTSC instruction operation is performed.

The RDMSR and WRMSR instructions read and write the time-stamp counter, treating the time-stamp counter as an ordinary MSR (address 10H). In the Pentium 4, Intel Xeon, and P6 family processors, all 64-bits of the time-stamp counter are read using RDMSR (just as with RDTSC). When WRMSR is used to write the time-stamp counter on processors before family [0FH], models [03H, 04H]: only the low-order 32-bits of the time-stamp counter can be written (the high-order 32 bits are cleared to 0). For family [0FH], models [03H, 04H, 06H]; for family [06H]], model [0EH, 0FH]; for family [06H]], DisplayModel [17H, 1AH, 1CH, 1DH]: all 64 bits are writable.

### 17.12.1 Invariant TSC

The time stamp counter in newer processors may support an enhancement, referred to as invariant TSC. Processor's support for invariant TSC is indicated by CPUID.80000007H:EDX[8].

The invariant TSC will run at a constant rate in all ACPI P-, C-, and T-states. This is the architectural behavior moving forward. On processors with invariant TSC support, the OS may use the TSC for wall clock timer services (instead of ACPI or HPET timers). TSC reads are much more efficient and do not incur the overhead associated with a ring transition or access to a platform resource.

## 17.12.2 IA32\_TSC\_AUX Register and RDTSCP Support

Processors based on Intel microarchitecture code name Nehalem provide an auxiliary TSC register, IA32\_TSC\_AUX that is designed to be used in conjunction with IA32\_TSC. IA32\_TSC\_AUX provides a 32-bit field that is initialized by privileged software with a signature value (for example, a logical processor ID).

The primary usage of IA32\_TSC\_AUX in conjunction with IA32\_TSC is to allow software to read the 64-bit time stamp in IA32\_TSC and signature value in IA32\_TSC\_AUX with the instruction RDTSCP in an atomic operation. RDTSCP returns the 64-bit time stamp in EDX:EAX and the 32-bit TSC\_AUX signature value in ECX. The atomicity of RDTSCP ensures that no context switch can occur between the reads of the TSC and TSC\_AUX values.

Support for RDTSCP is indicated by CPUID.80000001H:EDX[27]. As with RDTSC instruction, non-ring 0 access is controlled by CR4.TSD (Time Stamp Disable flag).

User mode software can use RDTSCP to detect if CPU migration has occurred between successive reads of the TSC. It can also be used to adjust for per-CPU differences in TSC values in a NUMA system.

# CHAPTER 18

## PERFORMANCE MONITORING

---

Intel 64 and IA-32 architectures provide facilities for monitoring performance.

### 18.1 PERFORMANCE MONITORING OVERVIEW

Performance monitoring was introduced in the Pentium processor with a set of model-specific performance-monitoring counter MSRs. These counters permit selection of processor performance parameters to be monitored and measured. The information obtained from these counters can be used for tuning system and compiler performance.

In Intel P6 family of processors, the performance monitoring mechanism was enhanced to permit a wider selection of events to be monitored and to allow greater control events to be monitored. Next, Pentium 4 and Intel Xeon processors introduced a new performance monitoring mechanism and new set of performance events.

The performance monitoring mechanisms and performance events defined for the Pentium, P6 family, Pentium 4, and Intel Xeon processors are not architectural. They are all model specific (not compatible among processor families). Intel Core Solo and Intel Core Duo processors support a set of architectural performance events and a set of non-architectural performance events. Processors based on Intel Core microarchitecture and Intel® Atom™ microarchitecture support enhanced architectural performance events and non-architectural performance events.

Starting with Intel Core Solo and Intel Core Duo processors, there are two classes of performance monitoring capabilities. The first class supports events for monitoring performance using counting or sampling usage. These events are non-architectural and vary from one processor model to another. They are similar to those available in Pentium M processors. These non-architectural performance monitoring events are specific to the microarchitecture and may change with enhancements. They are discussed in Section 18.3, “Performance Monitoring (Intel® Core™ Solo and Intel® Core™ Duo Processors).” Non-architectural events for a given microarchitecture can not be enumerated using CPUID; and they are listed in Chapter 19, “Performance-Monitoring Events.”

The second class of performance monitoring capabilities is referred to as architectural performance monitoring. This class supports the same counting and sampling usages, with a smaller set of available events. The visible behavior of architectural performance events is consistent across processor implementations. Availability of architectural performance monitoring capabilities is enumerated using the CPUID.0AH. These events are discussed in Section 18.2.

See also:



- Section 18.2, “Architectural Performance Monitoring”
- Section 18.3, “Performance Monitoring (Intel® Core™ Solo and Intel® Core™ Duo Processors)”
- Section 18.4, “Performance Monitoring (Processors Based on Intel® Core™ Microarchitecture)”
- Section 18.5, “Performance Monitoring (Processors Based on Intel® Atom™ Microarchitecture)”
- Section 18.6, “Performance Monitoring for Processors Based on Intel® Microarchitecture Code Name Nehalem”
- Section 18.7, “Performance Monitoring for Processors Based on Intel® Microarchitecture Code Name Westmere”
- Section 18.8, “Performance Monitoring for Processors Based on Intel® Microarchitecture Code Name Sandy Bridge”
- Section 18.8.8, “Intel® Xeon® Processor E5 Family Uncore Performance Monitoring Facility”
- Section 18.10, “Performance Monitoring (Processors Based on Intel NetBurst® Microarchitecture)”
- Section 18.11, “Performance Monitoring and Intel Hyper-Threading Technology in Processors Based on Intel NetBurst® Microarchitecture”
- Section 18.14, “Performance Monitoring and Dual-Core Technology”
- Section 18.15, “Performance Monitoring on 64-bit Intel Xeon Processor MP with Up to 8-MByte L3 Cache”
- Section 18.17, “Performance Monitoring (P6 Family Processor)”
- Section 18.18, “Performance Monitoring (Pentium Processors)”

## 18.2 ARCHITECTURAL PERFORMANCE MONITORING

Performance monitoring events are architectural when they behave consistently across microarchitectures. Intel Core Solo and Intel Core Duo processors introduced architectural performance monitoring. The feature provides a mechanism for software to enumerate performance events and provides configuration and counting facilities for events.

Architectural performance monitoring does allow for enhancement across processor implementations. The CPUID.0AH leaf provides version ID for each enhancement. Intel Core Solo and Intel Core Duo processors support base level functionality identified by version ID of 1. Processors based on Intel Core microarchitecture support, at a minimum, the base level functionality of architectural performance monitoring. Intel Core 2 Duo processor T 7700 and newer processors based on Intel Core

microarchitecture support both the base level functionality and enhanced architectural performance monitoring identified by version ID of 2.

Intel Atom processor family supports the base level functionality, enhanced architectural performance monitoring identified by version ID of 2 and version ID of 3 (including two general-purpose performance counters, IA32\_PMC0, IA32\_PMC1). Intel Core i7 processor family supports the base level functionality, enhanced architectural performance monitoring identified by version ID of 2 and version ID of 3, (including four general-purpose performance counters, IA32\_PMC0-IA32\_PMC3).

## 18.2.1 Architectural Performance Monitoring Version 1

Configuring an architectural performance monitoring event involves programming performance event select registers. There are a finite number of performance event select MSRs (IA32\_PERFEVTSELx MSRs). The result of a performance monitoring event is reported in a performance monitoring counter (IA32\_PMCx MSR). Performance monitoring counters are paired with performance monitoring select registers.

Performance monitoring select registers and counters are architectural in the following respects:

- Bit field layout of IA32\_PERFEVTSELx is consistent across microarchitectures.
- Addresses of IA32\_PERFEVTSELx MSRs remain the same across microarchitectures.
- Addresses of IA32\_PMC MSRs remain the same across microarchitectures.
- Each logical processor has its own set of IA32\_PERFEVTSELx and IA32\_PMCx MSRs. Configuration facilities and counters are not shared between logical processors sharing a processor core.

Architectural performance monitoring provides a CPUID mechanism for enumerating the following information:

- Number of performance monitoring counters available in a logical processor (each IA32\_PERFEVTSELx MSR is paired to the corresponding IA32\_PMCx MSR)
- Number of bits supported in each IA32\_PMCx
- Number of architectural performance monitoring events supported in a logical processor

Software can use CPUID to discover architectural performance monitoring availability (CPUID.0AH). The architectural performance monitoring leaf provides an identifier corresponding to the version number of architectural performance monitoring available in the processor.

The version identifier is retrieved by querying CPUID.0AH:EAX[bits 7:0] (see Chapter 3, “Instruction Set Reference, A-L,” in the *Intel® 64 and IA-32 Architectures Software Developer’s Manual, Volume 2A*). If the version identifier is greater than zero, architectural performance monitoring capability is supported. Software queries the CPUID.0AH for the version identifier first; it then analyzes the value returned in CPUID.0AH.EAX, CPUID.0AH.EBX to determine the facilities available.

In the initial implementation of architectural performance monitoring; software can determine how many IA32\_PERFEVTSELx/ IA32\_PMCx MSR pairs are supported per core, the bit-width of PMC, and the number of architectural performance monitoring events available.

### 18.2.1.1 Architectural Performance Monitoring Version 1 Facilities

Architectural performance monitoring facilities include a set of performance monitoring counters and performance event select registers. These MSRs have the following properties:

- IA32\_PMCx MSRs start at address 0C1H and occupy a contiguous block of MSR address space; the number of MSRs per logical processor is reported using CPUID.0AH:EAX[15:8].
- IA32\_PERFEVTSELx MSRs start at address 186H and occupy a contiguous block of MSR address space. Each performance event select register is paired with a corresponding performance counter in the 0C1H address block.
- The bit width of an IA32\_PMCx MSR is reported using the CPUID.0AH:EAX[23:16]. This is the number of valid bits for read operation. On write operations, the lower-order 32 bits of the MSR may be written with any value, and the high-order bits are sign-extended from the value of bit 31.
- Bit field layout of IA32\_PERFEVTSELx MSRs is defined architecturally.

See Figure 18-1 for the bit field layout of IA32\_PERFEVTSELx MSRs. The bit fields are:

- **Event select field (bits 0 through 7)** — Selects the event logic unit used to detect microarchitectural conditions (see Table 18-1, for a list of architectural events and their 8-bit codes). The set of values for this field is defined architecturally; each value corresponds to an event logic unit for use with an architectural performance event. The number of architectural events is queried using CPUID.0AH:EAX. A processor may support only a subset of pre-defined values.

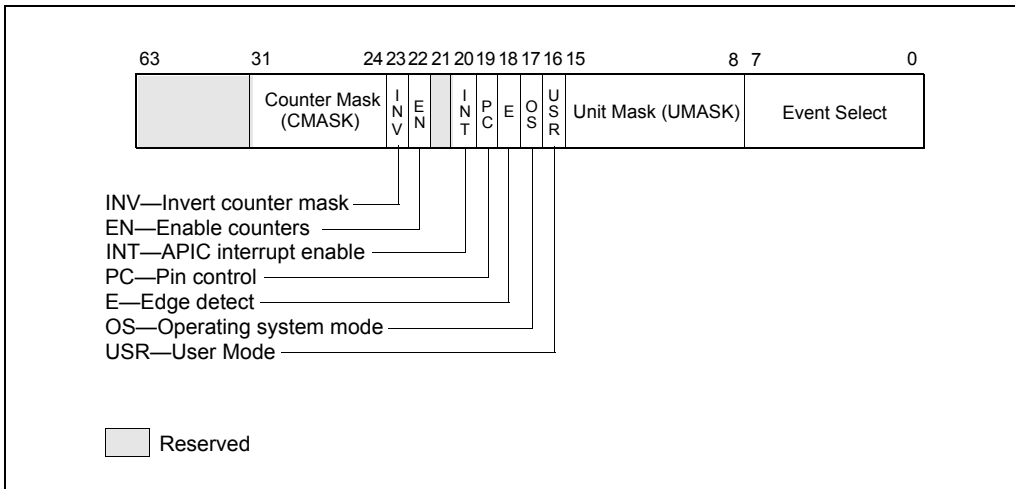


Figure 18-1. Layout of IA32\_PERFVTSELx MSRs

- Unit mask (UMASK) field (bits 8 through 15)** — These bits qualify the condition that the selected event logic unit detects. Valid UMASK values for each event logic unit are specific to the unit. For each architectural performance event, its corresponding UMASK value defines a specific microarchitectural condition.
 

A pre-defined microarchitectural condition associated with an architectural event may not be applicable to a given processor. The processor then reports only a subset of pre-defined architectural events. Pre-defined architectural events are listed in Table 18-1; support for pre-defined architectural events is enumerated using CPUID.0AH:EBX. Architectural performance events available in the initial implementation are listed in Table 19-1.
- USR (user mode) flag (bit 16)** — Specifies that the selected microarchitectural condition is counted only when the logical processor is operating at privilege levels 1, 2 or 3. This flag can be used with the OS flag.
- OS (operating system mode) flag (bit 17)** — Specifies that the selected microarchitectural condition is counted only when the logical processor is operating at privilege level 0. This flag can be used with the USR flag.
- E (edge detect) flag (bit 18)** — Enables (when set) edge detection of the selected microarchitectural condition. The logical processor counts the number of deasserted to asserted transitions for any condition that can be expressed by the other fields. The mechanism does not permit back-to-back assertions to be distinguished.

This mechanism allows software to measure not only the fraction of time spent in a particular state, but also the average length of time spent in such a state (for example, the time spent waiting for an interrupt to be serviced).

- **PC (pin control) flag (bit 19)** — When set, the logical processor toggles the PMi pins and increments the counter when performance-monitoring events occur; when clear, the processor toggles the PMi pins when the counter overflows. The toggling of a pin is defined as assertion of the pin for a single bus clock followed by deassertion.
- **INT (APIC interrupt enable) flag (bit 20)** — When set, the logical processor generates an exception through its local APIC on counter overflow.
- **EN (Enable Counters) Flag (bit 22)** — When set, performance counting is enabled in the corresponding performance-monitoring counter; when clear, the corresponding counter is disabled. The event logic unit for a UMASK must be disabled by setting IA32\_PERFEVTSELx[bit 22] = 0, before writing to IA32\_PMCx.
- **INV (invert) flag (bit 23)** — Inverts the result of the counter-mask comparison when set, so that both greater than and less than comparisons can be made.
- **Counter mask (CMASK) field (bits 24 through 31)** — When this field is not zero, a logical processor compares this mask to the events count of the detected microarchitectural condition during a single cycle. If the event count is greater than or equal to this mask, the counter is incremented by one. Otherwise the counter is not incremented.

This mask is intended for software to characterize microarchitectural conditions that can count multiple occurrences per cycle (for example, two or more instructions retired per clock; or bus queue occupations). If the counter-mask field is 0, then the counter is incremented each cycle by the event count associated with multiple occurrences.

## 18.2.2 Additional Architectural Performance Monitoring Extensions

The enhanced features provided by architectural performance monitoring version 2 include the following:

- **Fixed-function performance counter register and associated control register** — Three of the architectural performance events are counted using three fixed-function MSRs (IA32\_FIXED\_CTR0 through IA32\_FIXED\_CTR2). Each of the fixed-function PMC can count only one architectural performance event. Configuring the fixed-function PMCs is done by writing to bit fields in the MSR (IA32\_FIXED\_CTR\_CTRL) located at address 38DH. Unlike configuring performance events for general-purpose PMCs (IA32\_PMCx) via UMASK field in (IA32\_PERFEVTSELx), configuring, programming IA32\_FIXED\_CTR\_CTRL for fixed-function PMCs do not require any UMASK.
- **Simplified event programming** — Most frequent operation in programming performance events are enabling/disabling event counting and checking the status of counter overflows. Architectural performance event version 2 provides three architectural MSRs:

- IA32\_PERF\_GLOBAL\_CTRL allows software to enable/disable event counting of all or any combination of fixed-function PMCs (IA32\_FIXED\_CTRx) or any general-purpose PMCs via a single WRMSR.
- IA32\_PERF\_GLOBAL\_STATUS allows software to query counter overflow conditions on any combination of fixed-function PMCs or general-purpose PMCs via a single RDMSR.
- IA32\_PERF\_GLOBAL\_OVF\_CTRL allows software to clear counter overflow conditions on any combination of fixed-function PMCs or general-purpose PMCs via a single WRMSR.

### 18.2.2.1 Architectural Performance Monitoring Version 2 Facilities

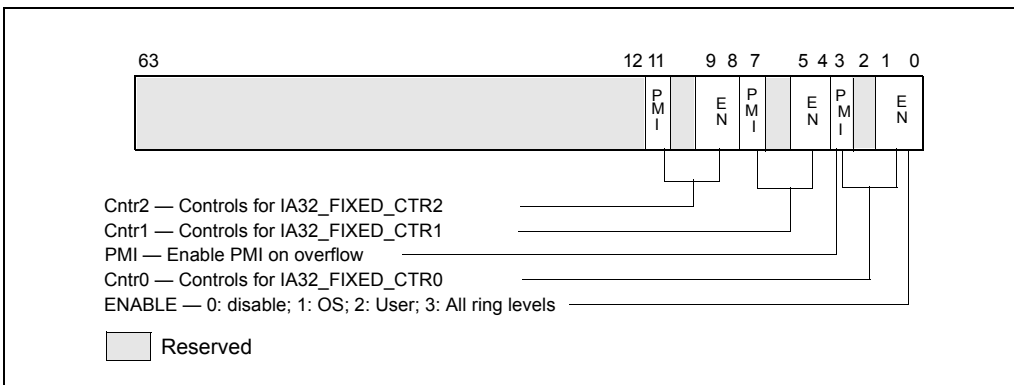
The facilities provided by architectural performance monitoring version 2 can be queried from CPUID leaf 0AH by examining the content of register EDX:

- Bits 0 through 4 of CPUID.0AH.EDX indicates the number of fixed-function performance counters available per core,
- Bits 5 through 12 of CPUID.0AH.EDX indicates the bit-width of fixed-function performance counters. Bits beyond the width of the fixed-function counter are reserved and must be written as zeros.

**NOTE**

Early generation of processors based on Intel Core microarchitecture may report in CPUID.0AH:EDX of support for version 2 but indicating incorrect information of version 2 facilities.

The IA32\_FIXED\_CTR\_CTRL MSR include multiple sets of 4-bit field, each 4 bit field controls the operation of a fixed-function performance counter. Figure 18-2 shows the layout of 4-bit controls for each fixed-function PMC. Two sub-fields are currently defined within each control. The definitions of the bit fields are:



**Figure 18-2. Layout of IA32\_FIXED\_CTR\_CTRL MSR**

- Enable field (lowest 2 bits within each 4-bit control)** — When bit 0 is set, performance counting is enabled in the corresponding fixed-function performance counter to increment while the target condition associated with the architecture performance event occurred at ring 0. When bit 1 is set, performance counting is enabled in the corresponding fixed-function performance counter to increment while the target condition associated with the architecture performance event occurred at ring greater than 0. Writing 0 to both bits stops the performance counter. Writing a value of 11B enables the counter to increment irrespective of privilege levels.
- PMI field (the fourth bit within each 4-bit control)** — When set, the logical processor generates an exception through its local APIC on overflow condition of the respective fixed-function counter.

IA32\_PERF\_GLOBAL\_CTRL MSR provides single-bit controls to enable counting of each performance counter. Figure 18-3 shows the layout of IA32\_PERF\_GLOBAL\_CTRL. Each enable bit in IA32\_PERF\_GLOBAL\_CTRL is AND’ed with the enable bits for all privilege levels in the respective IA32\_PERFEVTSELx or IA32\_PERF\_FIXED\_CTR\_CTRL MSRs to start/stop the counting of respective counters. Counting is enabled if the AND’ed results is true; counting is disabled when the result is false.

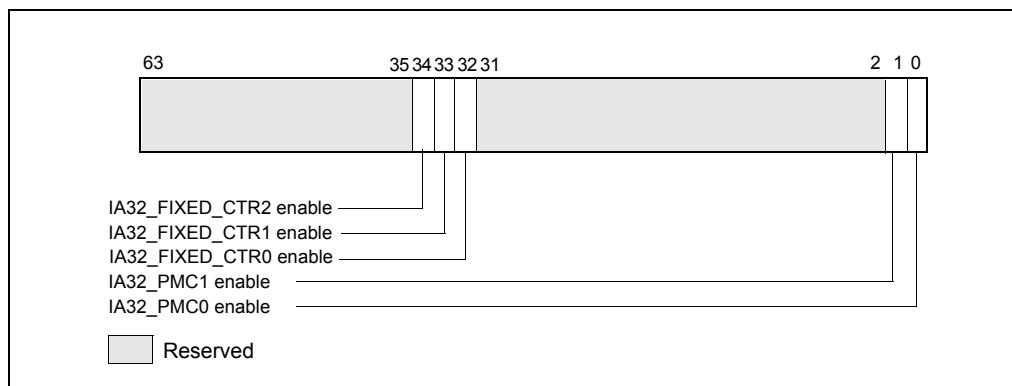


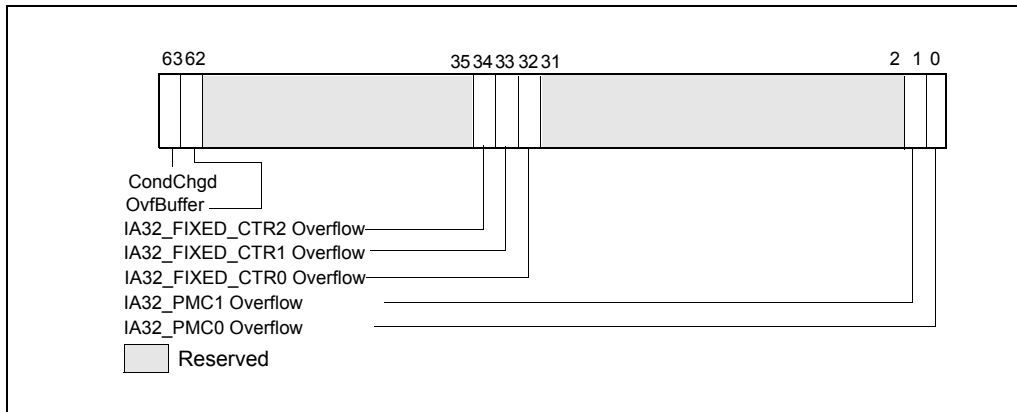
Figure 18-3. Layout of IA32\_PERF\_GLOBAL\_CTRL MSR

The fixed-function performance counters supported by architectural performance version 2 is listed in Table 18-8, the pairing between each fixed-function performance counter to an architectural performance event is also shown.

IA32\_PERF\_GLOBAL\_STATUS MSR provides single-bit status for software to query the overflow condition of each performance counter. The MSR also provides additional status bit to indicate overflow conditions when counters are programmed for precise-event-based sampling (PEBS). IA32\_PERF\_GLOBAL\_STATUS MSR also provides a sticky bit to indicate changes to the state of performance monitoring hard-

ware. Figure 18-4 shows the layout of IA32\_PERF\_GLOBAL\_STATUS. A value of 1 in bits 0, 1, 32 through 34 indicates a counter overflow condition has occurred in the associated counter.

When a performance counter is configured for PEBS, overflow condition in the counter generates a performance-monitoring interrupt signaling a PEBS event. On a PEBS event, the processor stores data records into the buffer area (see Section 18.15.5), clears the counter overflow status., and sets the “OvfBuffer” bit in IA32\_PERF\_GLOBAL\_STATUS.



**Figure 18-4. Layout of IA32\_PERF\_GLOBAL\_STATUS MSR**

IA32\_PERF\_GLOBAL\_OVF\_CTL MSR allows software to clear overflow indicator(s) of any general-purpose or fixed-function counters via a single WRMSR. Software should clear overflow indications when

- Setting up new values in the event select and/or UMASK field for counting or sampling
- Reloading counter values to continue sampling
- Disabling event counting or sampling.

The layout of IA32\_PERF\_GLOBAL\_OVF\_CTL is shown in Figure 18-5.



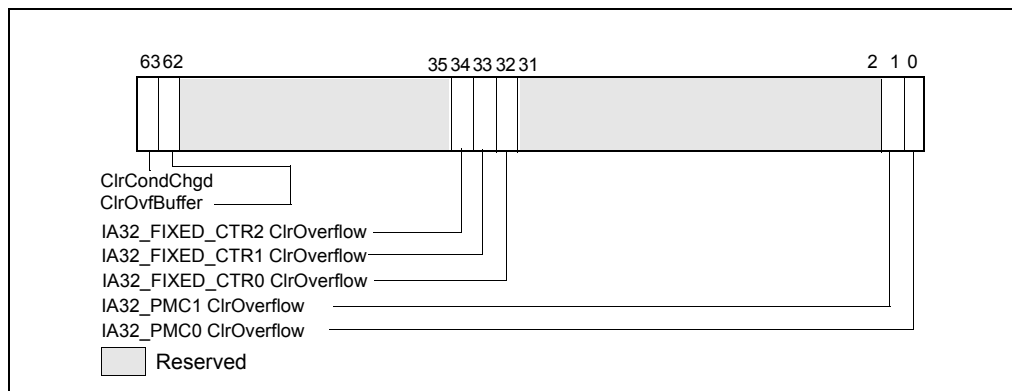
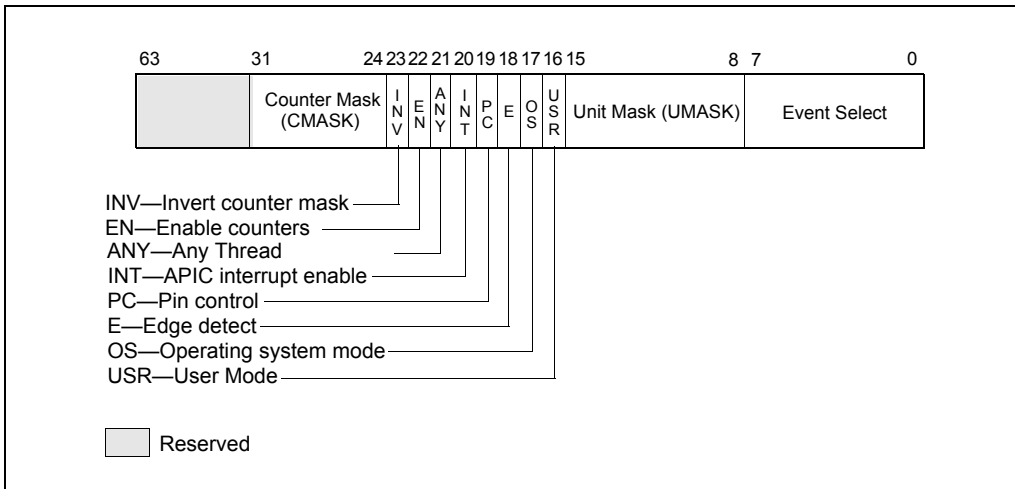


Figure 18-5. Layout of IA32\_PERF\_GLOBAL\_OVF\_CTRL MSR

### 18.2.2.2 Architectural Performance Monitoring Version 3 Facilities

The facilities provided by architectural performance monitoring version 1 and 2 are also supported by architectural performance monitoring version 3. Additionally version 3 provides enhancements to support a processor core comprising of more than one logical processor, i.e. a processor core supporting Intel Hyper-Threading Technology or simultaneous multi-threading capability. Specifically,

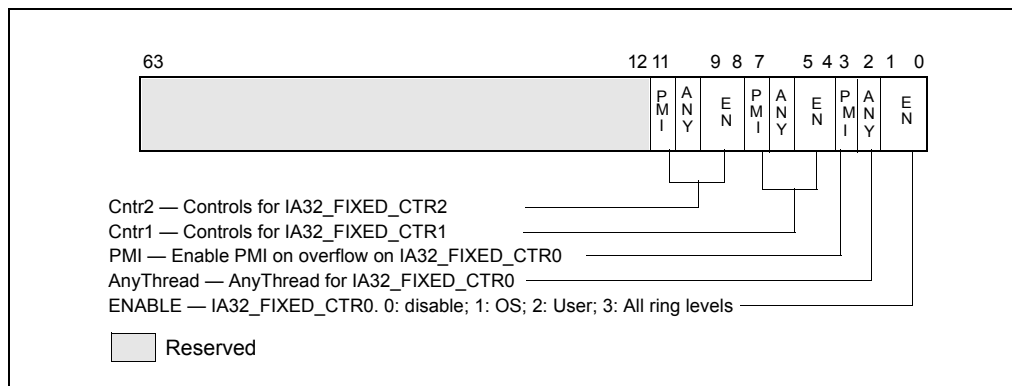
- CPUID leaf 0AH provides enumeration mechanisms to query:
  - The number of general-purpose performance counters (IA32\_PMCx) is reported in CPUID.0AH:EAX[15:8], the bit width of general-purpose performance counters (see also Section 18.2.1.1) is reported in CPUID.0AH:EAX[23:16].
  - The bit vector representing the set of architectural performance monitoring events supported (see Section 18.2.3)
  - The number of fixed-function performance counters, the bit width of fixed-function performance counters (see also Section 18.2.2.1).
- Each general-purpose performance counter IA32\_PMCx (starting at MSR address 0C1H) is associated with a corresponding IA32\_PERFEVTSELx MSR (starting at MSR address 186H). The Bit field layout of IA32\_PERFEVTSELx MSRs is defined architecturally in Figure 18-6.



**Figure 18-6. Layout of IA32\_PERFEVTSELx MSRs Supporting Architectural Performance Monitoring Version 3**

**Bit 21 (AnyThread)** of IA32\_PERFEVTSELx is supported in architectural performance monitoring version 3. When set to 1, it enables counting the associated event conditions (including matching the thread's CPL with the OS/USR setting of IA32\_PERFEVTSELx) occurring across all logical processors sharing a processor core. When bit 21 is 0, the counter only increments the associated event conditions (including matching the thread's CPL with the OS/USR setting of IA32\_PERFEVTSELx) occurring in the logical processor which programmed the IA32\_PERFEVTSELx MSR.

- Each fixed-function performance counter IA32\_FIXED\_CTRx (starting at MSR address 309H) is configured by a 4-bit control block in the IA32\_PERF\_FIXED\_CTR\_CTRL MSR. The control block also allow thread-specificity configuration using an AnyThread bit. The layout of IA32\_PERF\_FIXED\_CTR\_CTRL MSR is shown.



**Figure 18-7. Layout of IA32\_FIXED\_CTR\_CTRL MSR Supporting Architectural Performance Monitoring Version 3**

Each control block for a fixed-function performance counter provides a **AnyThread** (bit position  $2 + 4*N$ ,  $N = 0, 1, \text{etc.}$ ) bit. When set to 1, it enables counting the associated event conditions (including matching the thread’s CPL with the ENABLE setting of the corresponding control block of IA32\_PERF\_FIXED\_CTR\_CTRL) occurring across all logical processors sharing a processor core. When an **AnyThread** bit is 0 in IA32\_PERF\_FIXED\_CTR\_CTRL, the corresponding fixed counter only increments the associated event conditions occurring in the logical processor which programmed the IA32\_PERF\_FIXED\_CTR\_CTRL MSR.

- The IA32\_PERF\_GLOBAL\_CTRL, IA32\_PERF\_GLOBAL\_STATUS, IA32\_PERF\_GLOBAL\_OVF\_CTRL MSRs provide single-bit controls/status for each general-purpose and fixed-function performance counter. Figure 18-8 shows the layout of these MSR for N general-purpose performance counters (where N is reported by CPUID.0AH:EAX[15:8] ) and three fixed-function counters.

**Note:** Intel Atom processor family supports two general-purpose performance monitoring counters (i.e.  $N = 2$  in Figure 18-8), other processor families in Intel 64 architecture may support a different value of N in Figure 18-8. The number N is reported by CPUID.0AH:EAX[15:8]. Intel Core i7 processor family supports four general-purpose performance monitoring counters (i.e.  $N = 4$  in Figure 18-8)

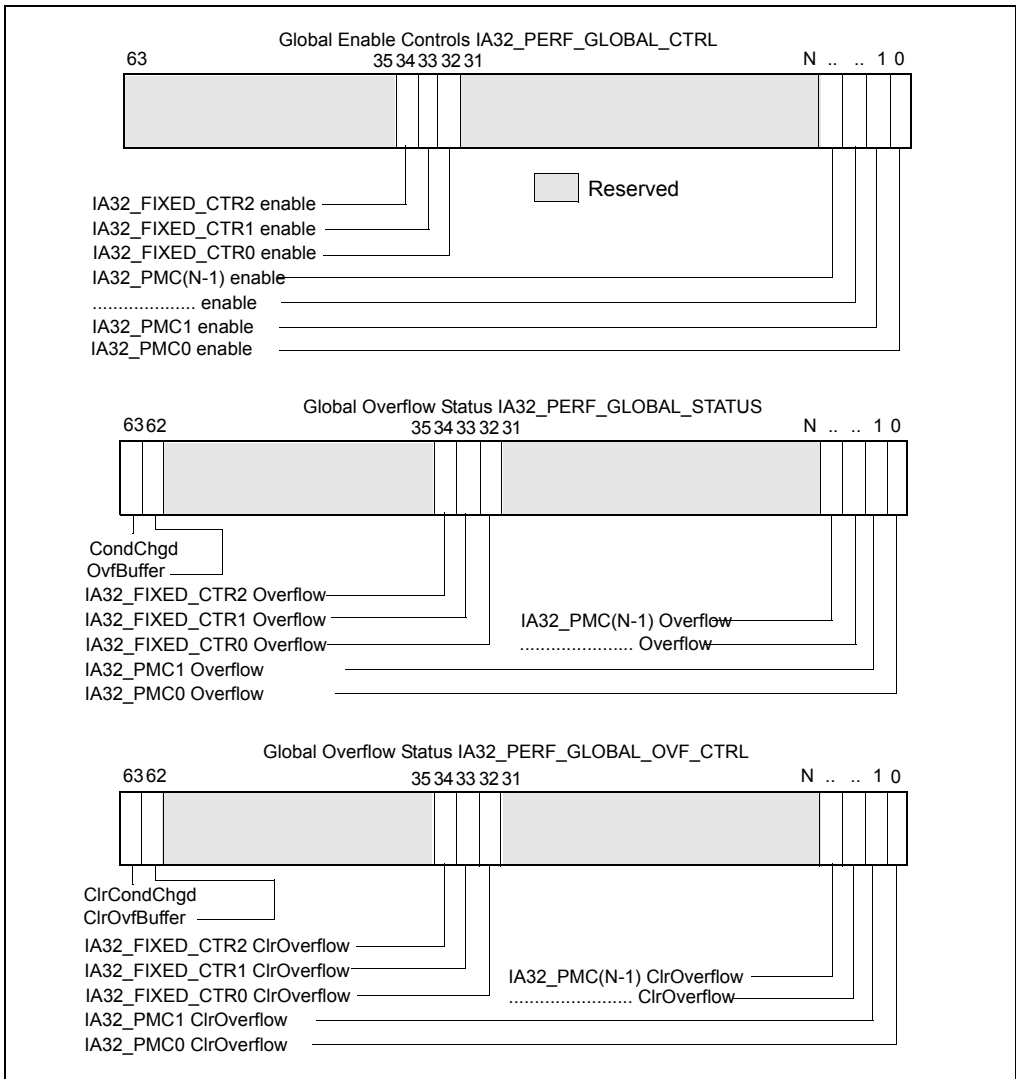


Figure 18-8. Layout of Global Performance Monitoring Control MSR

### 18.2.2.3 Full-Width Writes to Performance Counter Registers

The general-purpose performance counter registers IA32\_PMCx are writable via WRMSR instruction. However, the value written into IA32\_PMCx by WRMSR is the signed extended 64-bit value of the EAX[31:0] input of WRMSR.

A processor that supports full-width writes to the general-purpose performance counters enumerated by CPUID.0AH:EAX[15:8] will set

IA32\_PERF\_CAPABILITIES[13] to enumerate its full-width-write capability See Figure 18-39.

If IA32\_PERF\_CAPABILITIES.FW\_WRITE[bit 13] =1, each IA32\_PMCi is accompanied by a corresponding alias address starting at 4C1H for IA32\_A\_PMC0.

If IA32\_A\_PMCi is present, the 64-bit input value (EDX:EAX) of WRMSR to IA32\_A\_PMCi will cause IA32\_PMCi to be updated by:

IA32\_PMCi[63:32] ← SignExtend(EDX[N-32:0]);

IA32\_PMCi[31:0] ← EAX[31:0];

### 18.2.3 Pre-defined Architectural Performance Events

Table 18-1 lists architecturally defined events.

**Table 18-1. UMask and Event Select Encodings for Pre-Defined Architectural Performance Events**

Bit Position CPUID.AH.EBX	Event Name	UMask	Event Select
0	UnHalted Core Cycles	00H	3CH
1	Instruction Retired	00H	C0H
2	UnHalted Reference Cycles	01H	3CH
3	LLC Reference	4FH	2EH
4	LLC Misses	41H	2EH
5	Branch Instruction Retired	00H	C4H
6	Branch Misses Retired	00H	C5H

A processor that supports architectural performance monitoring may not support all the predefined architectural performance events (Table 18-1). The non-zero bits in CPUID.0AH:EBX indicate the events that are not available.

The behavior of each architectural performance event is expected to be consistent on all processors that support that event. Minor variations between microarchitectures are noted below:

- **UnHalted Core Cycles** — Event select 3CH, Umask 00H

This event counts core clock cycles when the clock signal on a specific core is running (not halted). The counter does not advance in the following conditions:

- an ACPI C-state other than C0 for normal operation
- HLT
- STPCLK# pin asserted
- being throttled by TM1

- during the frequency switching phase of a performance state transition (see Chapter 14, “Power and Thermal Management”)

The performance counter for this event counts across performance state transitions using different core clock frequencies

- **Instructions Retired** — Event select C0H, Umask 00H

This event counts the number of instructions at retirement. For instructions that consist of multiple micro-ops, this event counts the retirement of the last micro-op of the instruction. An instruction with a REP prefix counts as one instruction (not per iteration). Faults before the retirement of the last micro-op of a multi-ops instruction are not counted.

This event does not increment under VM-exit conditions. Counters continue counting during hardware interrupts, traps, and inside interrupt handlers.

- **UnHalted Reference Cycles** — Event select 3CH, Umask 01H

This event counts reference clock cycles while the clock signal on the core is running. The reference clock operates at a fixed frequency, irrespective of core frequency changes due to performance state transitions. Processors may implement this behavior differently. See Table 19-13 and Table 19-15 in Chapter 19, “Performance-Monitoring Events.”

- **Last Level Cache References** — Event select 2EH, Umask 4FH

This event counts requests originating from the core that reference a cache line in the last level cache. The event count includes speculation and cache line fills due to the first-level cache hardware prefetcher, but may exclude cache line fills due to other hardware-prefetchers.

Because cache hierarchy, cache sizes and other implementation-specific characteristics; value comparison to estimate performance differences is not recommended.

- **Last Level Cache Misses** — Event select 2EH, Umask 41H

This event counts each cache miss condition for references to the last level cache. The event count may include speculation and cache line fills due to the first-level cache hardware prefetcher, but may exclude cache line fills due to other hardware-prefetchers.

Because cache hierarchy, cache sizes and other implementation-specific characteristics; value comparison to estimate performance differences is not recommended.

- **Branch Instructions Retired** — Event select C4H, Umask 00H

This event counts branch instructions at retirement. It counts the retirement of the last micro-op of a branch instruction.

- **All Branch Mispredict Retired** — Event select C5H, Umask 00H

This event counts mispredicted branch instructions at retirement. It counts the retirement of the last micro-op of a branch instruction in the architectural path of execution and experienced misprediction in the branch prediction hardware.

Branch prediction hardware is implementation-specific across microarchitectures; value comparison to estimate performance differences is not recommended.

### NOTE

Programming decisions or software precisians on functionality should not be based on the event values or dependent on the existence of performance monitoring events.

## 18.3 PERFORMANCE MONITORING (INTEL® CORE™ SOLO AND INTEL® CORE™ DUO PROCESSORS)

In Intel Core Solo and Intel Core Duo processors, non-architectural performance monitoring events are programmed using the same facilities (see Figure 18-1) used for architectural performance events.

Non-architectural performance events use event select values that are model-specific. Event mask (Umask) values are also specific to event logic units. Some microarchitectural conditions detectable by a Umask value may have specificity related to processor topology (see Section 8.6, “Detecting Hardware Multi-Threading Support and Topology,” in the *Intel® 64 and IA-32 Architectures Software Developer’s Manual, Volume 3A*). As a result, the unit mask field (for example, IA32\_PERFEVTSELx[bits 15:8]) may contain sub-fields that specify topology information of processor cores.

The sub-field layout within the Umask field may support two-bit encoding that qualifies the relationship between a microarchitectural condition and the originating core. This data is shown in Table 18-2. The two-bit encoding for core-specificity is only supported for a subset of Umask values (see Chapter 19, “Performance Monitoring Events”) and for Intel Core Duo processors. Such events are referred to as core-specific events.

**Table 18-2. Core Specificity Encoding within a Non-Architectural Umask**

IA32_PERFEVTSELx MSRs	
Bit 15:14 Encoding	Description
11B	All cores
10B	Reserved
01B	This core
00B	Reserved

Some microarchitectural conditions allow detection specificity only at the boundary of physical processors. Some bus events belong to this category, providing specificity between the originating physical processor (a bus agent) versus other agents on the bus. Sub-field encoding for agent specificity is shown in Table 18-3.

**Table 18-3. Agent Specificity Encoding within a Non-Architectural Umask**

IA32_PERFEVTSELx MSRs	
Bit 13 Encoding	Description
0	This agent
1	Include all agents

Some microarchitectural conditions are detectable only from the originating core. In such cases, unit mask does not support core-specificity or agent-specificity encodings. These are referred to as core-only conditions.

Some microarchitectural conditions allow detection specificity that includes or excludes the action of hardware prefetches. A two-bit encoding may be supported to qualify hardware prefetch actions. Typically, this applies only to some L2 or bus events. The sub-field encoding for hardware prefetch qualification is shown in Table 18-4.

**Table 18-4. HW Prefetch Qualification Encoding within a Non-Architectural Umask**

IA32_PERFEVTSELx MSRs	
Bit 13:12 Encoding	Description
11B	All inclusive
10B	Reserved
01B	Hardware prefetch only
00B	Exclude hardware prefetch

Some performance events may (a) support none of the three event-specific qualification encodings (b) may support core-specificity and agent specificity simultaneously (c) or may support core-specificity and hardware prefetch qualification simultaneously. Agent-specificity and hardware prefetch qualification are mutually exclusive.

In addition, some L2 events permit qualifications that distinguish cache coherent states. The sub-field definition for cache coherency state qualification is shown in Table 18-5. If no bits in the MESI qualification sub-field are set for an event that requires setting MESI qualification bits, the event count will not increment.

**Table 18-5. MESI Qualification Definitions within a Non-Architectural Umask**

IA32_PERFEVTSELx MSRs	
Bit Position 11:8	Description
Bit 11	Counts modified state
Bit 10	Counts exclusive state



**Table 18-5. MESI Qualification Definitions within a Non-Architectural Umask**

IA32_PERFEVTSELx MSRs	
Bit Position 11:8	Description
Bit 9	Counts shared state
Bit 8	Counts Invalid state

## 18.4 PERFORMANCE MONITORING (PROCESSORS BASED ON INTEL® CORE™ MICROARCHITECTURE)

In addition to architectural performance monitoring, processors based on the Intel Core microarchitecture support non-architectural performance monitoring events.

Architectural performance events can be collected using general-purpose performance counters. Non-architectural performance events can be collected using general-purpose performance counters (coupled with two IA32\_PERFEVTSELx MSRs for detailed event configurations), or fixed-function performance counters (see Section 18.4.1). IA32\_PERFEVTSELx MSRs are architectural; their layout is shown in Figure 18-1. Starting with Intel Core 2 processor T 7700, fixed-function performance counters and associated counter control and status MSR becomes part of architectural performance monitoring version 2 facilities (see also Section 18.2.2).

Non-architectural performance events in processors based on Intel Core microarchitecture use event select values that are model-specific. Valid event mask (Umask) bits are listed in Chapter 19. The UMASK field may contain sub-fields identical to those listed in Table 18-2, Table 18-3, Table 18-4, and Table 18-5. One or more of these sub-fields may apply to specific events on an event-by-event basis. Details are listed in Table 19-13 in Chapter 19, "Performance-Monitoring Events."

In addition, the UMASK field may also contain a sub-field that allows detection specificity related to snoop responses. Bits of the snoop response qualification sub-field are defined in Table 18-6.

**Table 18-6. Bus Snoop Qualification Definitions within a Non-Architectural Umask**

IA32_PERFEVTSELx MSRs	
Bit Position 11:8	Description
Bit 11	HITM response
Bit 10	Reserved
Bit 9	HIT response
Bit 8	CLEAN response

There are also non-architectural events that support qualification of different types of snoop operation. The corresponding bit field for snoop type qualification are listed in Table 18-7.

**Table 18-7. Snoop Type Qualification Definitions within a Non-Architectural Umask**

IA32_PERFEVTSELx MSRs	
Bit Position 9:8	Description
Bit 9	CMP2I snoops
Bit 8	CMP2S snoops

No more than one sub-field of MESI, snoop response, and snoop type qualification sub-fields can be supported in a performance event.

### NOTE

Software must write known values to the performance counters prior to enabling the counters. The content of general-purpose counters and fixed-function counters are undefined after INIT or RESET.

## 18.4.1 Fixed-function Performance Counters

Processors based on Intel Core microarchitecture provide three fixed-function performance counters. Bits beyond the width of the fixed counter are reserved and must be written as zeros. Model-specific fixed-function performance counters on processors that support Architectural Perfmon version 1 are 40 bits wide.

Each of the fixed-function counter is dedicated to count a pre-defined performance monitoring events. The performance monitoring events associated with fixed-function counters and the addresses of these counters are listed in Table 18-8.

**Table 18-8. Association of Fixed-Function Performance Counters with Architectural Performance Events**

Event Name	Fixed-Function PMC	PMC Address
INST_RETIRED.ANY	MSR_PERF_FIXED_CTR0/ A32_FIXED_CTR0	309H
CPU_CLK_UNHALTED.CORE	MSR_PERF_FIXED_CTR1// IA32_FIXED_CTR1	30AH
CPU_CLK_UNHALTED.REF	MSR_PERF_FIXED_CTR2// IA32_FIXED_CTR2	30BH

Programming the fixed-function performance counters does not involve any of the

IA32\_PERFEVTSELx MSRs, and does not require specifying any event masks. Instead, the MSR MSR\_PERF\_FIXED\_CTR\_CTRL provides multiple sets of 4-bit fields; each 4-bit field controls the operation of a fixed-function performance counter (PMC). See Figures 18-9. Two sub-fields are defined for each control. See Figure 18-9; bit fields are:

- Enable field (low 2 bits in each 4-bit control)** — When bit 0 is set, performance counting is enabled in the corresponding fixed-function performance counter to increment when the target condition associated with the architecture performance event occurs at ring 0.

When bit 1 is set, performance counting is enabled in the corresponding fixed-function performance counter to increment when the target condition associated with the architecture performance event occurs at ring greater than 0.

Writing 0 to both bits stops the performance counter. Writing 11B causes the counter to increment irrespective of privilege levels.

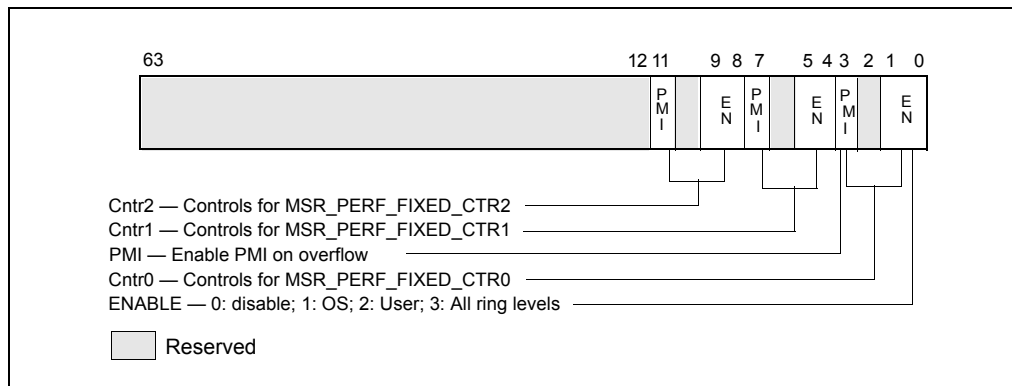


Figure 18-9. Layout of MSR\_PERF\_FIXED\_CTR\_CTRL MSR

- PMI field (fourth bit in each 4-bit control)** — When set, the logical processor generates an exception through its local APIC on overflow condition of the respective fixed-function counter.

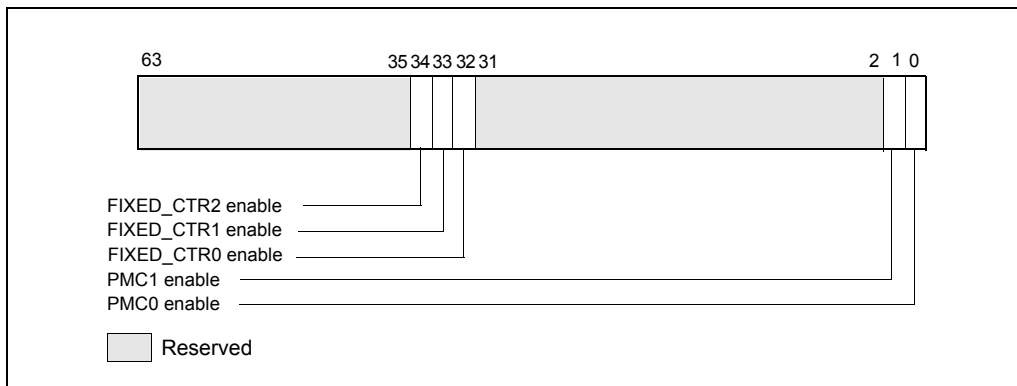
## 18.4.2 Global Counter Control Facilities

Processors based on Intel Core microarchitecture provides simplified performance counter control that simplifies the most frequent operations in programming performance events, i.e. enabling/disabling event counting and checking the status of counter overflows. This is done by the following three MSRs:

- MSR\_PERF\_GLOBAL\_CTRL enables/disables event counting for all or any combination of fixed-function PMCs (MSR\_PERF\_FIXED\_CTRx) or general-purpose PMCs via a single WRMSR.

- MSR\_PERF\_GLOBAL\_STATUS allows software to query counter overflow conditions on any combination of fixed-function PMCs (MSR\_PERF\_FIXED\_CTRx) or general-purpose PMCs via a single RDMSR.
- MSR\_PERF\_GLOBAL\_OVF\_CTRL allows software to clear counter overflow conditions on any combination of fixed-function PMCs (MSR\_PERF\_FIXED\_CTRx) or general-purpose PMCs via a single WRMSR.

MSR\_PERF\_GLOBAL\_CTRL MSR provides single-bit controls to enable counting in each performance counter (see Figure 18-10). Each enable bit in MSR\_PERF\_GLOBAL\_CTRL is AND'ed with the enable bits for all privilege levels in the respective IA32\_PERFECTSELx or MSR\_PERF\_FIXED\_CTR\_CTRL MSRs to start/stop the counting of respective counters. Counting is enabled if the AND'ed results is true; counting is disabled when the result is false.



**Figure 18-10. Layout of MSR\_PERF\_GLOBAL\_CTRL MSR**

MSR\_PERF\_GLOBAL\_STATUS MSR provides single-bit status used by software to query the overflow condition of each performance counter. The MSR also provides additional status bit to indicate overflow conditions when counters are programmed for precise-event-based sampling (PEBS). The MSR\_PERF\_GLOBAL\_STATUS MSR also provides a 'sticky bit' to indicate changes to the state of performance monitoring hardware (see Figure 18-11). A value of 1 in bits 34:32, 1, 0 indicates an overflow condition has occurred in the associated counter.

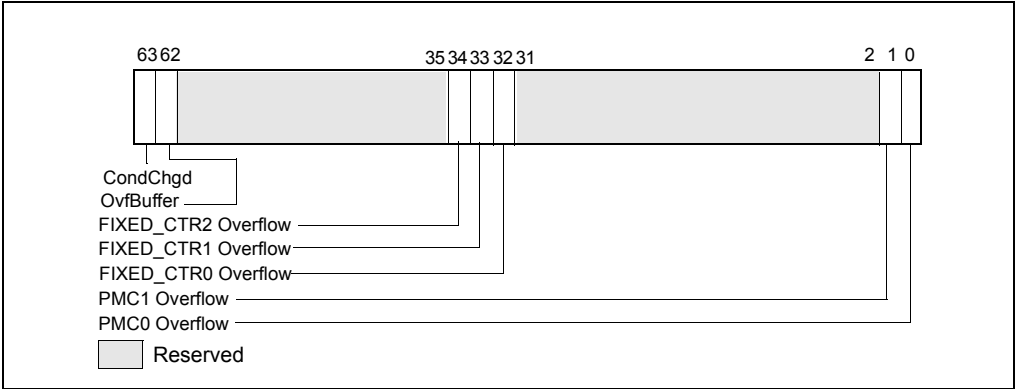


Figure 18-11. Layout of MSR\_PERF\_GLOBAL\_STATUS MSR

When a performance counter is configured for PEBS, an overflow condition in the counter generates a performance-monitoring interrupt this signals a PEBS event. On a PEBS event, the processor stores data records in the buffer area (see Section 17.4.9), clears the counter overflow status, and sets the OvfBuffer bit in MSR\_PERF\_GLOBAL\_STATUS.

MSR\_PERF\_GLOBAL\_OVF\_CTL MSR allows software to clear overflow the indicators for general-purpose or fixed-function counters via a single WRMSR (see Figure 18-12). Clear overflow indications when:

- Setting up new values in the event select and/or UMASK field for counting or sampling
- Reloading counter values to continue sampling
- Disabling event counting or sampling

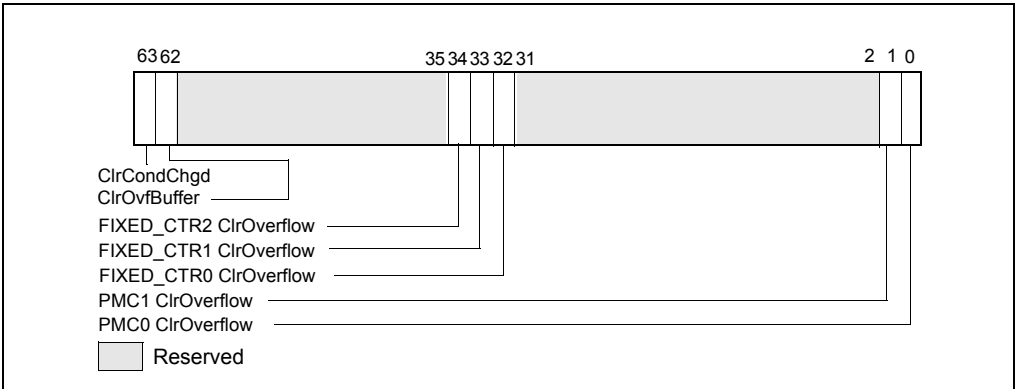


Figure 18-12. Layout of MSR\_PERF\_GLOBAL\_OVF\_CTL MSR

### 18.4.3 At-Retirement Events

Many non-architectural performance events are impacted by the speculative nature of out-of-order execution. A subset of non-architectural performance events on processors based on Intel Core microarchitecture are enhanced with a tagging mechanism (similar to that found in Intel NetBurst® microarchitecture) that exclude contributions that arise from speculative execution. The at-retirement events available in processors based on Intel Core microarchitecture does not require special MSR programming control (see Section 18.10.6, “At-Retirement Counting”), but is limited to IA32\_PMC0. See Table 18-9 for a list of events available to processors based on Intel Core microarchitecture.

**Table 18-9. At-Retirement Performance Events for Intel Core Microarchitecture**

Event Name	UMask	Event Select
ITLB_MISS_RETIRED	00H	C9H
MEM_LOAD_RETIRED.L1D_MISS	01H	CBH
MEM_LOAD_RETIRED.L1D_LINE_MISS	02H	CBH
MEM_LOAD_RETIRED.L2_MISS	04H	CBH
MEM_LOAD_RETIRED.L2_LINE_MISS	08H	CBH
MEM_LOAD_RETIRED.DTLB_MISS	10H	CBH

### 18.4.4 Precise Event Based Sampling (PEBS)

Processors based on Intel Core microarchitecture also support precise event based sampling (PEBS). This feature was introduced by processors based on Intel NetBurst microarchitecture.

PEBS uses a debug store mechanism and a performance monitoring interrupt to store a set of architectural state information for the processor. The information provides architectural state of the instruction executed after the instruction that caused the event (See Section 18.4.4.2).

In cases where the same instruction causes BTS and PEBS to be activated, PEBS is processed before BTS are processed. The PMI request is held until the processor completes processing of PEBS and BTS.

For processors based on Intel Core microarchitecture, events that support precise sampling are listed in Table 18-10. The procedure for detecting availability of PEBS is the same as described in Section 18.10.7.1.

**Table 18-10. PEBS Performance Events for Intel Core Microarchitecture**

Event Name	UMask	Event Select
INSTR_RETIRED.ANY_P	00H	C0H
X87_OPS_RETIRED.ANY	FEH	C1H

**Table 18-10. PEBS Performance Events for Intel Core Microarchitecture (Contd.)**

Event Name	UMask	Event Select
BR_INST_RETIRED.MISPRED	00H	C5H
SIMD_INST_RETIRED.ANY	1FH	C7H
MEM_LOAD_RETIRED.L1D_MISS	01H	CBH
MEM_LOAD_RETIRED.L1D_LINE_MISS	02H	CBH
MEM_LOAD_RETIRED.L2_MISS	04H	CBH
MEM_LOAD_RETIRED.L2_LINE_MISS	08H	CBH
MEM_LOAD_RETIRED.DTLB_MISS	10H	CBH

#### 18.4.4.1 Setting up the PEBS Buffer

For processors based on Intel Core microarchitecture, PEBS is available using IA32\_PMC0 only. Use the following procedure to set up the processor and IA32\_PMC0 counter for PEBS:

1. Set up the precise event buffering facilities. Place values in the precise event buffer base, precise event index, precise event absolute maximum, precise event interrupt threshold, and precise event counter reset fields of the DS buffer management area. In processors based on Intel Core microarchitecture, PEBS records consist of 64-bit address entries. See Figure 17-8 to set up the precise event records buffer in memory.
2. Enable PEBS. Set the Enable PEBS on PMC0 flag (bit 0) in IA32\_PEBS\_ENABLE MSR.
3. Set up the IA32\_PMC0 performance counter and IA32\_PERFEVTSEL0 for an event listed in Table 18-10.

#### 18.4.4.2 PEBS Record Format

The PEBS record format may be extended across different processor implementations. The IA32\_PERF\_CAPABILITIES MSR defines a mechanism for software to handle the evolution of PEBS record format in processors that support architectural performance monitoring with version id equals 2 or higher. The bit fields of IA32\_PERF\_CAPABILITIES are defined in Table 34-2 of Chapter 34, “Model-Specific Registers (MSRs)”. The relevant bit fields that governs PEBS are:

- PEBSTrap [bit 6]: When set, PEBS recording is trap-like. After the PEBS-enabled counter has overflowed, PEBS record is recorded for the next PEBS-able event at the completion of the sampled instruction causing the PEBS event. When clear, PEBS recording is fault-like. The PEBS record is recorded before the sampled instruction causing the PEBS event.
- PEBSSaveArchRegs [bit 7]: When set, PEBS will save architectural register and state information according to the encoded value of the PEBSRecordFormat field. On processors based on Intel Core microarchitecture, this bit is always 1

- PEBSRecordFormat [bits 11:8]: Valid encodings are:
  - 0000B: Only general-purpose registers, instruction pointer and RFLAGS registers are saved in each PEBS record (seeSection 18.10.7).

### 18.4.4.3 Writing a PEBS Interrupt Service Routine

The PEBS facilities share the same interrupt vector and interrupt service routine (called the DS ISR) with the non-precise event-based sampling and BTS facilities. To handle PEBS interrupts, PEBS handler code must be included in the DS ISR. See Section 17.4.9.1, “DS Save Area and IA-32e Mode Operation,” for guidelines when writing the DS ISR.

The service routine can query MSR\_PERF\_GLOBAL\_STATUS to determine which counter(s) caused of overflow condition. The service routine should clear overflow indicator by writing to MSR\_PERF\_GLOBAL\_OVF\_CTL.

A comparison of the sequence of requirements to program PEBS for processors based on Intel Core and Intel NetBurst microarchitectures is listed in Table 18-11.

**Table 18-11. Requirements to Program PEBS**

	For Processors based on Intel Core microarchitecture	For Processors based on Intel NetBurst microarchitecture
Verify PEBS support of processor/OS	<ul style="list-style-type: none"> <li>▪ IA32_MISC_ENABLE.EMON_AVAILABE (bit 7) is set.</li> <li>▪ IA32_MISC_ENABLE.PEBS_UNAVAILABE (bit 12) is clear.</li> </ul>	
Ensure counters are in disabled	<p>On initial set up or changing event configurations, write MSR_PERF_GLOBAL_CTRL MSR (0x38F) with 0.</p> <p>On subsequent entries:</p> <ul style="list-style-type: none"> <li>▪ Clear all counters if “Counter Freeze on PMI” is not enabled.</li> <li>▪ If IA32_DebugCTL.Freeze is enabled, counters are automatically disabled.</li> </ul> <p>Counters MUST be stopped before writing.<sup>1</sup></p>	Optional
Disable PEBS.	Clear ENABLE PMCO bit in IA32_PEBS_ENABLE MSR (0x3F1).	Optional
Check overflow conditions.	Check MSR_PERF_GLOBAL_STATUS MSR (0x 38E) handle any overflow conditions.	Check OVF flag of each CCCR for overflow condition



**Table 18-11. Requirements to Program PEBS (Contd.)**

	<b>For Processors based on Intel Core microarchitecture</b>	<b>For Processors based on Intel NetBurst microarchitecture</b>
Clear overflow status.	Clear MSR_PERF_GLOBAL_STATUS MSR (0x 38E) using IA32_PERF_GLOBAL_OVF_CTRL MSR (0x390).	Clear OVF flag of each CCCR.
Write "sample-after" values.	Configure the counter(s) with the sample after value.	
Configure specific counter configuration MSR.	<ul style="list-style-type: none"> <li>▪ Set local enable bit 22 - 1.</li> <li>▪ Do NOT set local counter PMI/INT bit, bit 20 - 0.</li> <li>▪ Event programmed must be PEBS capable.</li> </ul>	<ul style="list-style-type: none"> <li>▪ Set appropriate OVF_PMI bits - 1.</li> <li>▪ Only CCCR for MSR_IQ_COUNTER4 support PEBS.</li> </ul>
Allocate buffer for PEBS states.	Allocate a buffer in memory for the precise information.	
Program the IA32_DS_AREA MSR.	Program the IA32_DS_AREA MSR.	
Configure the PEBS buffer management records.	Configure the PEBS buffer management records in the DS buffer management area.	
Configure/Enable PEBS.	Set Enable PMCO bit in IA32_PEBS_ENABLE MSR (0x3F1).	Configure MSR_PEBS_ENABLE, MSR_PEBS_MATRIX_VERT and MSR_PEBS_MATRIX_HORZ as needed.
Enable counters.	Set Enable bits in MSR_PERF_GLOBAL_CTRL MSR (0x38F).	Set each CCCR enable bit 12 - 1.

**NOTES:**

1. Counters read while enabled are not guaranteed to be precise with event counts that occur in timing proximity to the RDMSR.

**18.4.4.4 Re-configuring PEBS Facilities**

When software needs to reconfigure PEBS facilities, it should allow a quiescent period between stopping the prior event counting and setting up a new PEBS event. The quiescent period is to allow any latent residual PEBS records to complete its capture at their previously specified buffer address (provided by IA32\_DS\_AREA).

## 18.5 PERFORMANCE MONITORING (PROCESSORS BASED ON INTEL® ATOM™ MICROARCHITECTURE)

Intel Atom processor family supports architectural performance monitoring capability with version ID 3 (see Section 18.2.2.2) and a host of non-architectural monitoring capabilities. The initial implementation of Intel Atom processor family provides two general-purpose performance counters (IA32\_PMC0, IA32\_PMC1) and three fixed-function performance counters (IA32\_FIXED\_CTR0, IA32\_FIXED\_CTR1, IA32\_FIXED\_CTR2).

Non-architectural performance monitoring in Intel Atom processor family uses the IA32\_PERFEVTSELx MSR to configure a set of non-architecture performance monitoring events to be counted by the corresponding general-purpose performance counter. The list of non-architectural performance monitoring events is listed in Table 19-14.

Architectural and non-architectural performance monitoring events in Intel Atom processor family support thread qualification using bit 21 of IA32\_PERFEVTSELx MSR.

The bit fields within each IA32\_PERFEVTSELx MSR are defined in Figure 18-6 and described in Section 18.2.1.1 and Section 18.2.2.2.

Valid event mask (Umask) bits are listed in Chapter 19. The UMASK field may contain sub-fields that provide the same qualifying actions like those listed in Table 18-2, Table 18-3, Table 18-4, and Table 18-5. One or more of these sub-fields may apply to specific events on an event-by-event basis. Details are listed in Table 19-14 in Chapter 19, "Performance-Monitoring Events." Precise Event Based Monitoring is supported using IA32\_PMC0 (see also Section 17.4.9, "BTS and DS Save Area").

## 18.6 PERFORMANCE MONITORING FOR PROCESSORS BASED ON INTEL® MICROARCHITECTURE CODE NAME NEHALEM

Intel Core i7 processor family<sup>1</sup> supports architectural performance monitoring capability with version ID 3 (see Section 18.2.2.2) and a host of non-architectural monitoring capabilities. The Intel Core i7 processor family is based on Intel® microarchitecture code name Nehalem, and provides four general-purpose performance counters (IA32\_PMC0, IA32\_PMC1, IA32\_PMC2, IA32\_PMC3) and three fixed-function performance counters (IA32\_FIXED\_CTR0, IA32\_FIXED\_CTR1, IA32\_FIXED\_CTR2) in the processor core.

---

1. Intel Xeon processor 5500 series and 3400 series are also based on Intel microarchitecture code name Nehalem, so the performance monitoring facilities described in this section generally also apply.

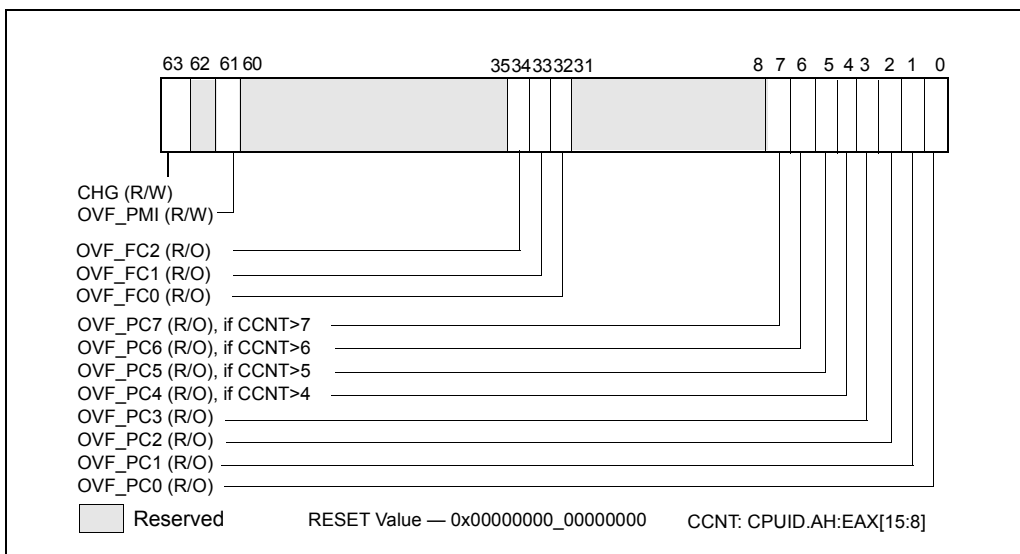
## PERFORMANCE MONITORING

Non-architectural performance monitoring in Intel Core i7 processor family uses the IA32\_PERFEVTSELx MSR to configure a set of non-architecture performance monitoring events to be counted by the corresponding general-purpose performance counter. The list of non-architectural performance monitoring events is listed in Table 19-14. Non-architectural performance monitoring events fall into two broad categories:

- Performance monitoring events in the processor core: These include many events that are similar to performance monitoring events available to processor based on Intel Core microarchitecture. Additionally, there are several enhancements in the performance monitoring capability for detecting microarchitectural conditions in the processor core or in the interaction of the processor core to the off-core sub-systems in the physical processor package. The off-core sub-systems in the physical processor package is loosely referred to as “uncore”.
- Performance monitoring events in the uncore: The uncore sub-system is shared by more than one processor cores in the physical processor package. It provides additional performance monitoring facility outside of IA32\_PMCx and performance monitoring events that are specific to the uncore sub-system.

Architectural and non-architectural performance monitoring events in Intel Core i7 processor family support thread qualification using bit 21 of IA32\_PERFEVTSELx MSR.

The bit fields within each IA32\_PERFEVTSELx MSR are defined in Figure 18-6 and described in Section 18.2.1.1 and Section 18.2.2.2.



**Figure 18-13. IA32\_PERF\_GLOBAL\_STATUS MSR**

## 18.6.1 Enhancements of Performance Monitoring in the Processor Core

The notable enhancements in the monitoring of performance events in the processor core include:

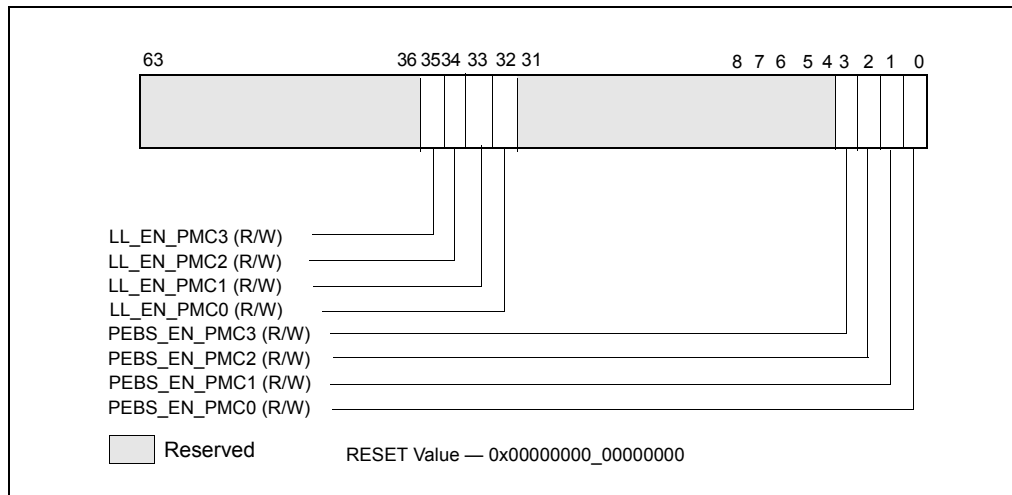
- Four general purpose performance counters, IA32\_PMCx, associated counter configuration MSRs, IA32\_PERFEVTSELx, and global counter control MSR supporting simplified control of four counters. Each of the four performance counter can support precise event based sampling (PEBS) and thread-qualification of architectural and non-architectural performance events. Width of IA32\_PMCx supported by hardware has been increased. The width of counter reported by CPUID.0AH:EAX[23:16] is 48 bits. The PEBS facility in Intel microarchitecture code name Nehalem has been enhanced to include new data format to capture additional information, such as load latency.
- Load latency sampling facility. Average latency of memory load operation can be sampled using load-latency facility in processors based on Intel microarchitecture code name Nehalem. The facility can measure average latency of load micro-operations from dispatch to when data is globally observable (GO). This facility is used in conjunction with the PEBS facility.
- Off-core response counting facility. This facility in the processor core allows software to count certain transaction responses between the processor core to sub-systems outside the processor core (uncore). Counting off-core response requires additional event qualification configuration facility in conjunction with IA32\_PERFEVTSELx. Two off-core response MSRs are provided to use in conjunction with specific event codes that must be specified with IA32\_PERFEVTSELx.

### 18.6.1.1 Precise Event Based Sampling (PEBS)

All four general-purpose performance counters, IA32\_PMCx, can be used for PEBS if the performance event supports PEBS. Software uses IA32\_MISC\_ENABLE[7] and IA32\_MISC\_ENABLE[12] to detect whether the performance monitoring facility and PEBS functionality are supported in the processor. The MSR IA32\_PEBS\_ENABLE provides 4 bits that software must use to enable which IA32\_PMCx overflow condition will cause the PEBS record to be captured.

Additionally, the PEBS record is expanded to allow latency information to be captured. The MSR IA32\_PEBS\_ENABLE provides 4 additional bits that software must use to enable latency data recording in the PEBS record upon the respective IA32\_PMCx overflow condition. The layout of IA32\_PEBS\_ENABLE for processors based on Intel microarchitecture code name Nehalem is shown in Figure 18-14.

When a counter is enabled to capture machine state (PEBS\_EN\_PMCx = 1), the processor will write machine state information to a memory buffer specified by software as detailed below. When the counter IA32\_PMCx overflows from maximum count to zero, the PEBS hardware is armed.



**Figure 18-14. Layout of IA32\_PEBE\_ENABLE MSR**

Upon occurrence of the next PEBS event, the PEBS hardware triggers an assist and causes a PEBS record to be written. The format of the PEBS record is indicated by the bit field IA32\_PERF\_CAPABILITIES[11:8] (see Figure 18-39).

The behavior of PEBS assists is reported by IA32\_PERF\_CAPABILITIES[6] (see Figure 18-39). The return instruction pointer (RIP) reported in the PEBS record will point to the instruction after (+1) the instruction that causes the PEBS assist. The machine state reported in the PEBS record is the machine state after the instruction that causes the PEBS assist is retired. For instance, if the instructions:

```
mov eax, [eax] ; causes PEBS assist
nop
```

are executed, the PEBS record will report the address of the nop, and the value of EAX in the PEBS record will show the value read from memory, not the target address of the read operation.

The PEBS record format is shown in Table 18-12, and each field in the PEBS record is 64 bits long. The PEBS record format, along with debug/store area storage format, does not change regardless of IA-32e mode is active or not.

CPUID.01H:ECX.DTES64[bit 2] reports the processor’s support for 64-bit debug/store area storage format is invariant to IA-32e mode.

**Table 18-12. PEBS Record Format for Intel Core i7 Processor Family**

Byte Offset	Field	Byte Offset	Field
0x0	R/EFLAGS	0x58	R9

**Table 18-12. PEBS Record Format for Intel Core i7 Processor Family**

Byte Offset	Field	Byte Offset	Field
0x8	R/EIP	0x60	R10
0x10	R/EAX	0x68	R11
0x18	R/EBX	0x70	R12
0x20	R/ECX	0x78	R13
0x28	R/EDX	0x80	R14
0x30	R/ESI	0x88	R15
0x38	R/EDI	0x90	IA32_PERF_GLOBAL_STATUS
0x40	R/EBP	0x98	Data Linear Address
0x48	R/ESP	0xA0	Data Source Encoding
0x50	R8	0xA8	Latency value (core cycles)

In IA-32e mode, the full 64-bit value is written to the register. If the processor is not operating in IA-32e mode, 32-bit value is written to registers with bits 63:32 zeroed. Registers not defined when the processor is not in IA-32e mode are written to zero.

Bytes 0xAF:0x90 are enhancement to the PEBS record format. Support for this enhanced PEBS record format is indicated by IA32\_PERF\_CAPABILITIES[11:8] encoding of 0001B.

The value written to bytes 0x97:0x90 is the state of the IA32\_PERF\_GLOBAL\_STATUS register before the PEBS assist occurred. This value is written so software can determine which counters overflowed when this PEBS record was written. Note that this field indicates the overflow status for all counters, regardless of whether they were programmed for PEBS or not.

### Programming PEBS Facility

Only a subset of non-architectural performance events in the processor support PEBS. The subset of precise events are listed in Table 18-10. In addition to using IA32\_PERFEVTSELx to specify event unit/mask settings and setting the EN\_PMCx bit in the IA32\_PEBS\_ENABLE register for the respective counter, the software must also initialize the DS\_BUFFER\_MANAGEMENT\_AREA data structure in memory to support capturing PEBS records for precise events.

### NOTE

PEBS events are only valid when the following fields of IA32\_PERFEVTSELx are all zero: AnyThread, Edge, Invert, CMask.

The beginning linear address of the DS\_BUFFER\_MANAGEMENT\_AREA data structure must be programmed into the IA32\_DS\_AREA register. The layout of the DS\_BUFFER\_MANAGEMENT\_AREA is shown in Figure 18-15.

- PEBS Buffer Base:** This field is programmed with the linear address of the first byte of the PEBS buffer allocated by software. The processor reads this field to determine the base address of the PEBS buffer. Software should allocate this memory from the non-paged pool.

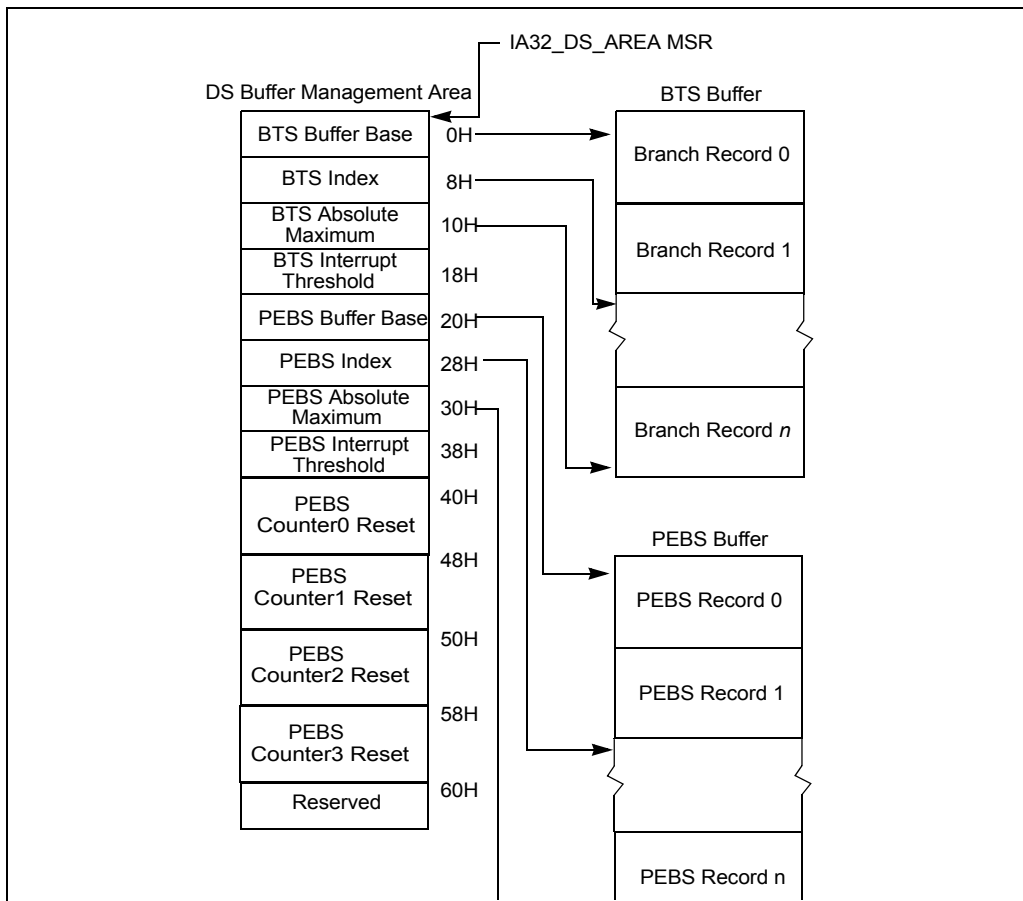


Figure 18-15. PEBS Programming Environment

- PEBS Index:** This field is initially programmed with the same value as the PEBS Buffer Base field, or the beginning linear address of the PEBS buffer. The processor reads this field to determine the location of the next PEBS record to write to. After a PEBS record has been written, the processor also updates this field with the address of the next PEBS record to be written. The figure above illustrates the state of PEBS Index after the first PEBS record is written.

- **PEBS Absolute Maximum:** This field represents the absolute address of the maximum length of the allocated PEBS buffer plus the starting address of the PEBS buffer. The processor will not write any PEBS record beyond the end of PEBS buffer, when **PEBS Index** equals **PEBS Absolute Maximum**. No signaling is generated when PEBS buffer is full. Software must reset the **PEBS Index** field to the beginning of the PEBS buffer address to continue capturing PEBS records.
- **PEBS Interrupt Threshold:** This field specifies the threshold value to trigger a performance interrupt and notify software that the PEBS buffer is nearly full. This field is programmed with the linear address of the first byte of the PEBS record within the PEBS buffer that represents the threshold record. After the processor writes a PEBS record and updates **PEBS Index**, if the **PEBS Index** reaches the threshold value of this field, the processor will generate a performance interrupt. This is the same interrupt that is generated by a performance counter overflow, as programmed in the Performance Monitoring Counters vector in the Local Vector Table of the Local APIC. When a performance interrupt due to PEBS buffer full is generated, the IA32\_PERF\_GLOBAL\_STATUS.PEBS\_Ovf bit will be set.
- **PEBS CounterX Reset:** This field allows software to set up PEBS counter overflow condition to occur at a rate useful for profiling workload, thereby generating multiple PEBS records to facilitate characterizing the profile the execution of test code. After each PEBS record is written, the processor checks each counter to see if it overflowed and was enabled for PEBS (the corresponding bit in IA32\_PEBS\_ENABLED was set). If these conditions are met, then the reset value for each overflowed counter is loaded from the DS Buffer Management Area. For example, if counter IA32\_PMC0 caused a PEBS record to be written, then the value of "PEBS Counter 0 Reset" would be written to counter IA32\_PMC0. If a counter is not enabled for PEBS, its value will not be modified by the PEBS assist.

### Performance Counter Prioritization

Performance monitoring interrupts are triggered by a counter transitioning from maximum count to zero (assuming IA32\_PerfEvtSelX.INT is set). This same transition will cause PEBS hardware to arm, but not trigger. PEBS hardware triggers upon detection of the first PEBS event after the PEBS hardware has been armed (a 0 to 1 transition of the counter). At this point, a PEBS assist will be undertaken by the processor.

Performance counters (fixed and general-purpose) are prioritized in index order. That is, counter IA32\_PMC0 takes precedence over all other counters. Counter IA32\_PMC1 takes precedence over counters IA32\_PMC2 and IA32\_PMC3, and so on. This means that if simultaneous overflows or PEBS assists occur, the appropriate action will be taken for the highest priority performance counter. For example, if IA32\_PMC1 cause an overflow interrupt and IA32\_PMC2 causes an PEBS assist simultaneously, then the overflow interrupt will be serviced first.

The PEBS threshold interrupt is triggered by the PEBS assist, and is by definition prioritized lower than the PEBS assist. Hardware will not generate separate interrupts for each counter that simultaneously overflows. General-purpose performance counters are prioritized over fixed counters.



If a counter is programmed with a precise (PEBS-enabled) event and programmed to generate a counter overflow interrupt, the PEBS assist is serviced before the counter overflow interrupt is serviced. If in addition the PEBS interrupt threshold is met, the threshold interrupt is generated after the PEBS assist completes, followed by the counter overflow interrupt (two separate interrupts are generated).

Uncore counters may be programmed to interrupt one or more processor cores (see Section 18.6.2). It is possible for interrupts posted from the uncore facility to occur coincident with counter overflow interrupts from the processor core. Software must check core and uncore status registers to determine the exact origin of counter overflow interrupts.

### 18.6.1.2 Load Latency Performance Monitoring Facility

The load latency facility provides software a means to characterize the average load latency to different levels of cache/memory hierarchy. This facility requires processor supporting enhanced PEBS record format in the PEBS buffer, see Table 18-12. The facility measures latency from micro-operation (uop) dispatch to when data is globally observable (GO).

To use this feature software must assure:

- One of the IA32\_PERFEVTSELx MSR is programmed to specify the event unit MEM\_INST\_RETIRED, and the LATENCY\_ABOVE\_THRESHOLD event mask must be specified (IA32\_PerfEvtSelX[15:0] = 0x100H). The corresponding counter IA32\_PMCx will accumulate event counts for architecturally visible loads which exceed the programmed latency threshold specified separately in a MSR. Stores are ignored when this event is programmed. The CMASK or INV fields of the IA32\_PerfEvtSelX register used for counting load latency must be 0. Writing other values will result in undefined behavior.
- The MSR\_PEBS\_LD\_LAT\_THRESHOLD MSR is programmed with the desired latency threshold in core clock cycles. Loads with latencies greater than this value are eligible for counting and latency data reporting. The minimum value that may be programmed in this register is 3 (the minimum detectable load latency is 4 core clock cycles).
- The PEBS enable bit in the IA32\_PEBS\_ENABLE register is set for the corresponding IA32\_PMCx counter register. This means that both the PEBS\_EN\_CTRX and LL\_EN\_CTRX bits must be set for the counter(s) of interest. For example, to enable load latency on counter IA32\_PMC0, the IA32\_PEBS\_ENABLE register must be programmed with the 64-bit value 0x00000001.00000001.

When the load-latency facility is enabled, load operations are randomly selected by hardware and tagged to carry information related to data source locality and latency. Latency and data source information of tagged loads are updated internally.

When a PEBS assist occurs, the last update of latency and data source information are captured by the assist and written as part of the PEBS record. The PEBS sample after value (SAV), specified in PEBS CounterX Reset, operates orthogonally to the tagging mechanism. Loads are randomly tagged to collect latency data. The SAV

controls the number of tagged loads with latency information that will be written into the PEBS record field by the PEBS assists. The load latency data written to the PEBS record will be for the last tagged load operation which retired just before the PEBS assist was invoked.

The load-latency information written into a PEBS record (see Table 18-12, bytes AFH:98H) consists of:

- **Data Linear Address:** This is the linear address of the target of the load operation.
- **Latency Value:** This is the elapsed cycles of the tagged load operation between dispatch to GO, measured in processor core clock domain.
- **Data Source :** The encoded value indicates the origin of the data obtained by the load instruction. The encoding is shown in Table 18-13. In the descriptions local memory refers to system memory physically attached to a processor package, and remote memory referrals to system memory physically attached to another processor package.

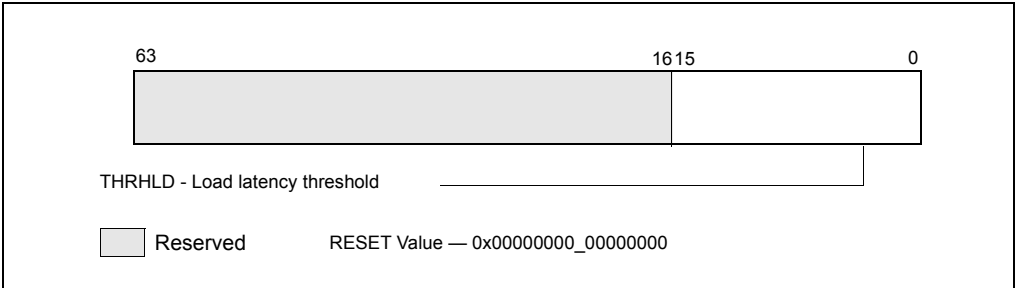
**Table 18-13. Data Source Encoding for Load Latency Record**

Encoding	Description
0x0	Unknown L3 cache miss
0x1	Minimal latency core cache hit. This request was satisfied by the L1 data cache.
0x2	Pending core cache HIT. Outstanding core cache miss to same cache-line address was already underway.
0x3	This data request was satisfied by the L2.
0x4	L3 HIT. Local or Remote home requests that hit L3 cache in the uncore with no coherency actions required (snooping).
0x5	L3 HIT. Local or Remote home requests that hit the L3 cache and was serviced by another processor core with a cross core snoop where no modified copies were found. (clean).
0x6	L3 HIT. Local or Remote home requests that hit the L3 cache and was serviced by another processor core with a cross core snoop where modified copies were found. (HITM).
0x7	Reserved
0x8	L3 MISS. Local homed requests that missed the L3 cache and was serviced by forwarded data following a cross package snoop where no modified copies found. (Remote home requests are not counted).
0x9	Reserved
0xA	L3 MISS. Local home requests that missed the L3 cache and was serviced by local DRAM (go to shared state).

**Table 18-13. Data Source Encoding for Load Latency Record (Contd.)**

Encoding	Description
0xB	L3 MISS. Remote home requests that missed the L3 cache and was serviced by remote DRAM (go to shared state).
0xC	L3 MISS. Local home requests that missed the L3 cache and was serviced by local DRAM (go to exclusive state).
0xD	L3 MISS. Remote home requests that missed the L3 cache and was serviced by remote DRAM (go to exclusive state).
0xE	I/O, Request of input/output operation
0xF	The request was to un-cacheable memory.

The layout of MSR\_PEBS\_LD\_LAT\_THRESHOLD is shown in Figure 18-16.



**Figure 18-16. Layout of MSR\_PEBS\_LD\_LAT MSR**

Bits 15:0 specifies the threshold load latency in core clock cycles. Performance events with latencies greater than this value are counted in IA32\_PMCx and their latency information is reported in the PEBS record. Otherwise, they are ignored. The minimum value that may be programmed in this field is 3.

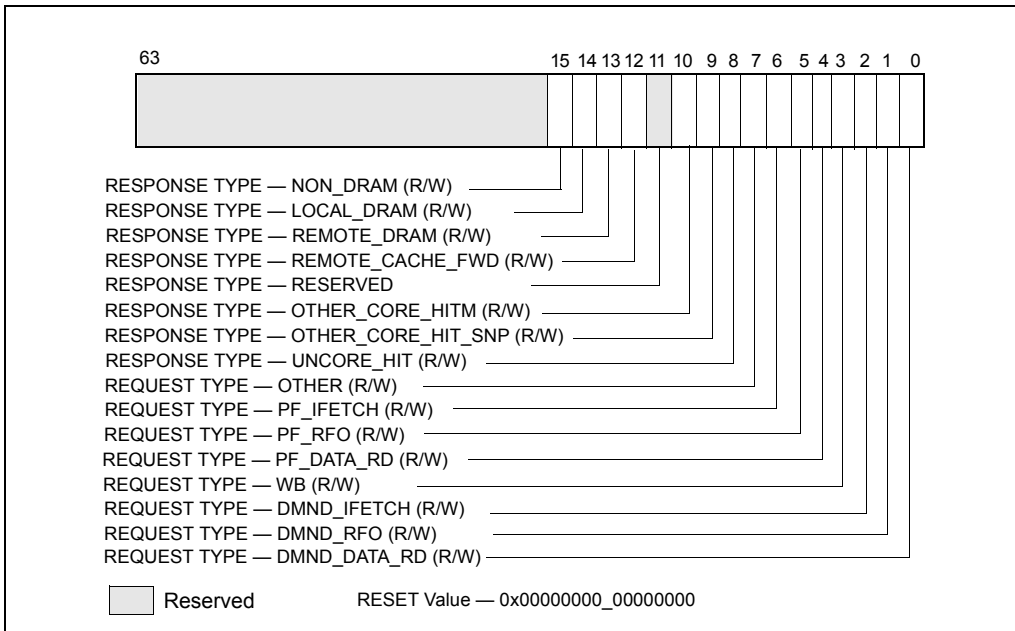
**18.6.1.3 Off-core Response Performance Monitoring in the Processor Core**

Performance an event using off-core response facility can program any of the four IA32\_PERFEVTSELx MSR with specific event codes and predefine mask bit value. Each event code for off-core response monitoring requires programming an associated configuration MSR, MSR\_OFFCORE\_RSP\_0. There is only one off-core response configuration MSR. Table 18-14 lists the event code, mask value and additional off-core configuration MSR that must be programmed to count off-core response events using IA32\_PMCx.

**Table 18-14. Off-Core Response Event Encoding**

Event code in IA32_PERFEVTSELx	Mask Value in IA32_PERFEVTSELx	Required Off-core Response MSR
0xB7	0x01	MSR_OFFCORE_RSP_0 (address 0x1A6)

The layout of MSR\_OFFCORE\_RSP\_0 is shown in Figure 18-17. Bits 7:0 specifies the request type of a transaction request to the uncore. Bits 15:8 specifies the response of the uncore subsystem.



**Figure 18-17. Layout of MSR\_OFFCORE\_RSP\_0 and MSR\_OFFCORE\_RSP\_1 to Configure Off-core Response Events**

**Table 18-15. MSR\_OFFCORE\_RSP\_0 and MSR\_OFFCORE\_RSP\_1 Bit Field Definition**

Bit Name	Offset	Description
DMND_DATA_RD	0	(R/W). Counts the number of demand and DCU prefetch data reads of full and partial cachelines as well as demand data page table entry cacheline reads. Does not count L2 data read prefetches or instruction fetches.

**Table 18-15. MSR\_OFFCORE\_RSP\_0 and MSR\_OFFCORE\_RSP\_1 Bit Field Definition**

Bit Name	Offset	Description
DMND_RFO	1	(R/W). Counts the number of demand and DCU prefetch reads for ownership (RFO) requests generated by a write to data cacheline. Does not count L2 RFO.
DMND_IFETCH	2	(R/W). Counts the number of demand and DCU prefetch instruction cacheline reads. Does not count L2 code read prefetches.
WB	3	(R/W). Counts the number of writeback (modified to exclusive) transactions.
PF_DATA_RD	4	(R/W). Counts the number of data cacheline reads generated by L2 prefetchers.
PF_RFO	5	(R/W). Counts the number of RFO requests generated by L2 prefetchers.
PF_IFETCH	6	(R/W). Counts the number of code reads generated by L2 prefetchers.
OTHER	7	(R/W). Counts one of the following transaction types, including L3 invalidate, I/O, full or partial writes, wC or non-temporal stores, CLFLUSH, Fences, lock, unlock, split lock.
UNCORE_HIT	8	(R/W). L3 Hit: local or remote home requests that hit L3 cache in the uncore with no coherency actions required (snooping).
OTHER_CORE_HIT_SNP	9	(R/W). L3 Hit: local or remote home requests that hit L3 cache in the uncore and was serviced by another core with a cross core snoop where no modified copies were found (clean).
OTHER_CORE_HITM	10	(R/W). L3 Hit: local or remote home requests that hit L3 cache in the uncore and was serviced by another core with a cross core snoop where modified copies were found (HITM).
Reserved	11	Reserved
REMOTE_CACHE_FWD	12	(R/W). L3 Miss: local homed requests that missed the L3 cache and was serviced by forwarded data following a cross package snoop where no modified copies found. (Remote home requests are not counted)
REMOTE_DRAM	13	(R/W). L3 Miss: remote home requests that missed the L3 cache and were serviced by remote DRAM.
LOCAL_DRAM	14	(R/W). L3 Miss: local home requests that missed the L3 cache and were serviced by local DRAM.
NON_DRAM	15	(R/W). Non-DRAM requests that were serviced by IOH.

## 18.6.2 Performance Monitoring Facility in the Uncore

The “uncore” in Intel microarchitecture code name Nehalem refers to subsystems in the physical processor package that are shared by multiple processor cores. Some of the sub-systems in the uncore include the L3 cache, Intel QuickPath Interconnect link logic, and integrated memory controller. The performance monitoring facilities inside the uncore operates in the same clock domain as the uncore (U-clock domain), which is usually different from the processor core clock domain. The uncore performance monitoring facilities described in this section apply to Intel Xeon processor 5500 series and processors with the following CUID signatures: 06\_1AH, 06\_1EH, 06\_1FH (see Chapter 34). An overview of the uncore performance monitoring facilities is described separately.

The performance monitoring facilities available in the U-clock domain consist of:

- Eight General-purpose counters (MSR\_UNCORE\_PerfCntr0 through MSR\_UNCORE\_PerfCntr7). The counters are 48 bits wide. Each counter is associated with a configuration MSR, MSR\_UNCORE\_PerfEvtSelx, to specify event code, event mask and other event qualification fields. A set of global uncore performance counter enabling/overflow/status control MSRs are also provided for software.
- Performance monitoring in the uncore provides an address/opcode match MSR that provides event qualification control based on address value or QPI command opcode.
- One fixed-function counter, MSR\_UNCORE\_FixedCntr0. The fixed-function uncore counter increments at the rate of the U-clock when enabled.

The frequency of the uncore clock domain can be determined from the uncore clock ratio which is available in the PCI configuration space register at offset COH under device number 0 and Function 0.

### 18.6.2.1 Uncore Performance Monitoring Management Facility

MSR\_UNCORE\_PERF\_GLOBAL\_CTRL provides bit fields to enable/disable general-purpose and fixed-function counters in the uncore. Figure 18-18 shows the layout of MSR\_UNCORE\_PERF\_GLOBAL\_CTRL for an uncore that is shared by four processor cores in a physical package.

- EN\_PCn (bit n, n = 0, 7): When set, enables counting for the general-purpose uncore counter MSR\_UNCORE\_PerfCntr n.
- EN\_FC0 (bit 32): When set, enables counting for the fixed-function uncore counter MSR\_UNCORE\_FixedCntr0.
- EN\_PMI\_COREn (bit n, n = 0, 3 if four cores are present): When set, processor core n is programmed to receive an interrupt signal from any interrupt enabled uncore counter. PMI delivery due to an uncore counter overflow is enabled by setting IA32\_DEBUG\_CTL.Offcore\_PMI\_EN to 1.
- PMI\_FRZ (bit 63): When set, all U-clock uncore counters are disabled when any one of them signals a performance interrupt. Software must explicitly re-enable

the counter by setting the enable bits in MSR\_UNCORE\_PERF\_GLOBAL\_CTRL upon exit from the ISR.

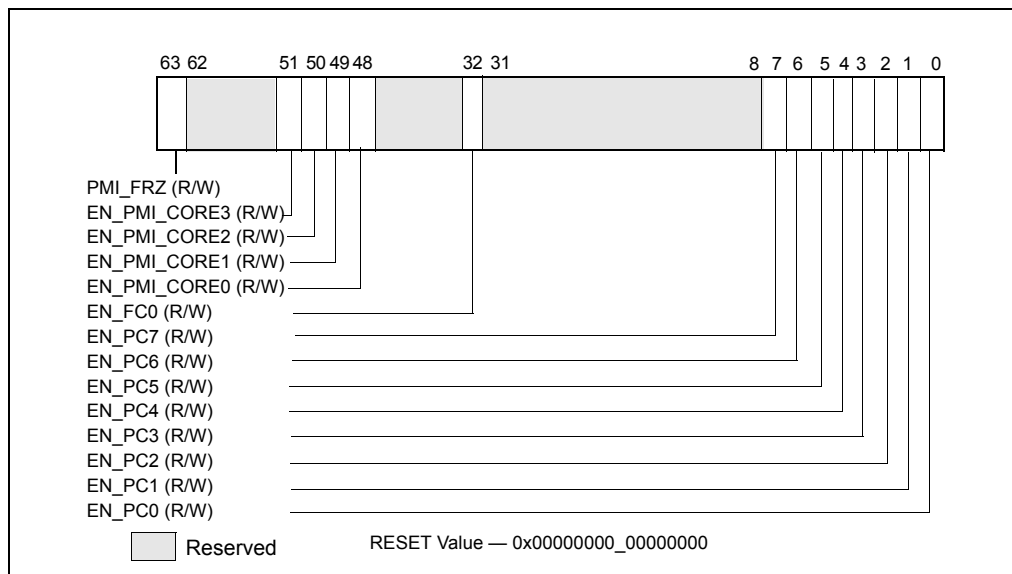


Figure 18-18. Layout of MSR\_UNCORE\_PERF\_GLOBAL\_CTRL MSR

MSR\_UNCORE\_PERF\_GLOBAL\_STATUS provides overflow status of the U-clock performance counters in the uncore. This is a read-only register. If an overflow status bit is set the corresponding counter has overflowed. The register provides a condition change bit (bit 63) which can be quickly checked by software to determine if a significant change has occurred since the last time the condition change status was cleared. Figure 18-19 shows the layout of MSR\_UNCORE\_PERF\_GLOBAL\_STATUS.

- OVF\_PCn (bit n, n = 0, 7): When set, indicates general-purpose uncore counter MSR\_UNCORE\_PerfCntr n has overflowed.
- OVF\_FC0 (bit 32): When set, indicates the fixed-function uncore counter MSR\_UNCORE\_FixedCntr0 has overflowed.
- OVF\_PMI (bit 61): When set indicates that an uncore counter overflowed and generated an interrupt request.
- CHG (bit 63): When set indicates that at least one status bit in MSR\_UNCORE\_PERF\_GLOBAL\_STATUS register has changed state.

MSR\_UNCORE\_PERF\_GLOBAL\_OVF\_CTRL allows software to clear the status bits in the UNCORE\_PERF\_GLOBAL\_STATUS register. This is a write-only register, and individual status bits in the global status register are cleared by writing a binary one to the corresponding bit in this register. Writing zero to any bit position in this register has no effect on the uncore PMU hardware.

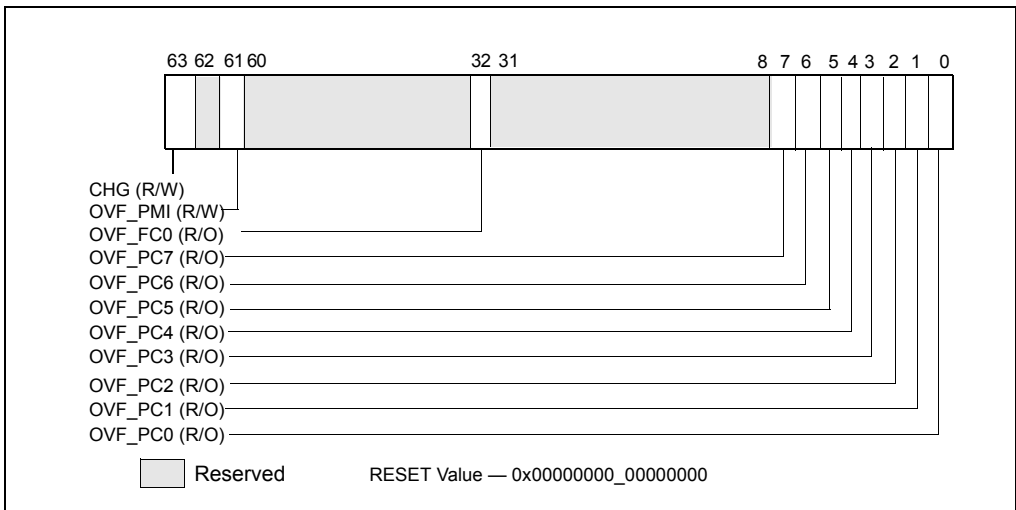


Figure 18-19. Layout of MSR\_UNCORE\_PERF\_GLOBAL\_STATUS MSR

Figure 18-20 shows the layout of MSR\_UNCORE\_PERF\_GLOBAL\_OVF\_CTRL.

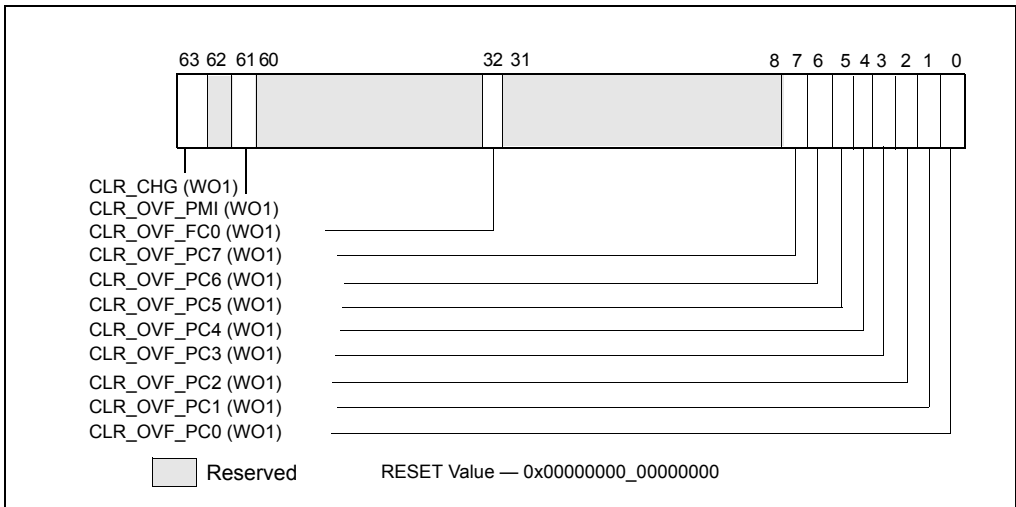


Figure 18-20. Layout of MSR\_UNCORE\_PERF\_GLOBAL\_OVF\_CTRL MSR



PERFORMANCE MONITORING

- CLR\_OVF\_PCn (bit n, n = 0, 7): Set this bit to clear the overflow status for general-purpose uncore counter MSR\_UNCORE\_PerfCntr n. Writing a value other than 1 is ignored.
- CLR\_OVF\_FC0 (bit 32): Set this bit to clear the overflow status for the fixed-function uncore counter MSR\_UNCORE\_FixedCntr0. Writing a value other than 1 is ignored.
- CLR\_OVF\_PMI (bit 61): Set this bit to clear the OVF\_PMI flag in MSR\_UNCORE\_PERF\_GLOBAL\_STATUS. Writing a value other than 1 is ignored.
- CLR\_CHG (bit 63): Set this bit to clear the CHG flag in MSR\_UNCORE\_PERF\_GLOBAL\_STATUS register. Writing a value other than 1 is ignored.

18.6.2.2 Uncore Performance Event Configuration Facility

MSR\_UNCORE\_PerfEvtSel0 through MSR\_UNCORE\_PerfEvtSel7 are used to select performance event and configure the counting behavior of the respective uncore performance counter. Each uncore PerfEvtSel MSR is paired with an uncore performance counter. Each uncore counter must be locally configured using the corresponding MSR\_UNCORE\_PerfEvtSelx and counting must be enabled using the respective EN\_PCx bit in MSR\_UNCORE\_PERF\_GLOBAL\_CTRL. Figure 18-21 shows the layout of MSR\_UNCORE\_PERFEVTSELx.

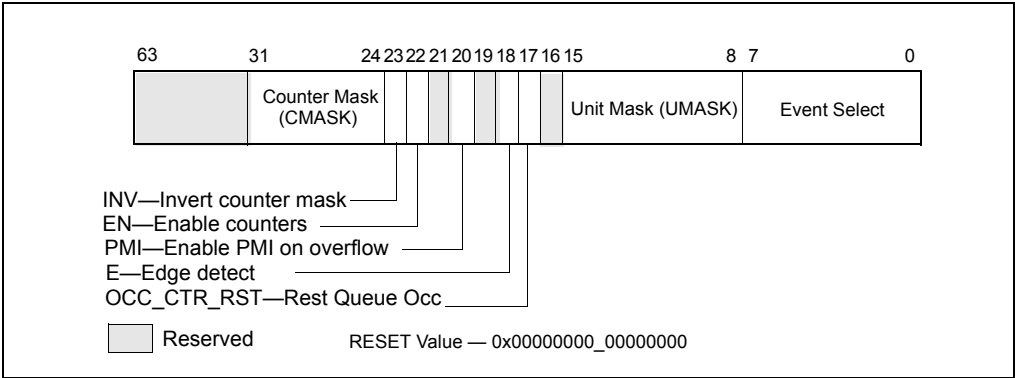
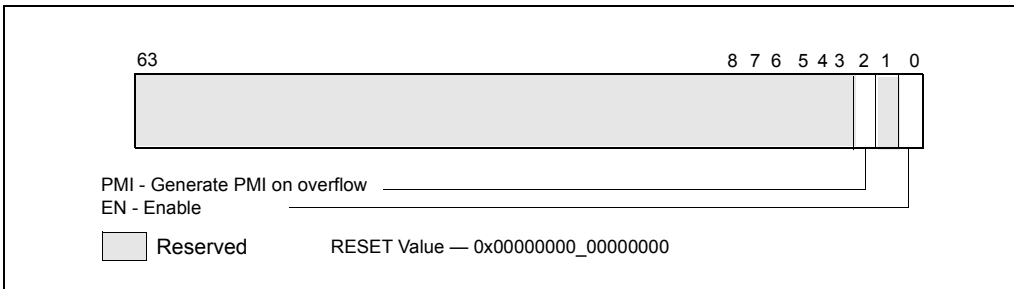


Figure 18-21. Layout of MSR\_UNCORE\_PERFEVTSELx MSRs

- Event Select (bits 7:0): Selects the event logic unit used to detect uncore events.
- Unit Mask (bits 15:8) : Condition qualifiers for the event selection logic specified in the Event Select field.
- OCC\_CTRL\_RST (bit17): When set causes the queue occupancy counter associated with this event to be cleared (zeroed). Writing a zero to this bit will be ignored. It will always read as a zero.

- Edge Detect (bit 18): When set causes the counter to increment when a deasserted to asserted transition occurs for the conditions that can be expressed by any of the fields in this register.
- PMI (bit 20): When set, the uncore will generate an interrupt request when this counter overflowed. This request will be routed to the logical processors as enabled in the PMI enable bits (EN\_PMI\_COREx) in the register MSR\_UNCORE\_PERF\_GLOBAL\_CTRL.
- EN (bit 22): When clear, this counter is locally disabled. When set, this counter is locally enabled and counting starts when the corresponding EN\_PCx bit in MSR\_UNCORE\_PERF\_GLOBAL\_CTRL is set.
- INV (bit 23): When clear, the Counter Mask field is interpreted as greater than or equal to. When set, the Counter Mask field is interpreted as less than.
- Counter Mask (bits 31:24): When this field is clear, it has no effect on counting. When set to a value other than zero, the logical processor compares this field to the event counts on each core clock cycle. If INV is clear and the event counts are greater than or equal to this field, the counter is incremented by one. If INV is set and the event counts are less than this field, the counter is incremented by one. Otherwise the counter is not incremented.

Figure 18-22 shows the layout of MSR\_UNCORE\_FIXED\_CTR\_CTRL.



**Figure 18-22. Layout of MSR\_UNCORE\_FIXED\_CTR\_CTRL MSR**

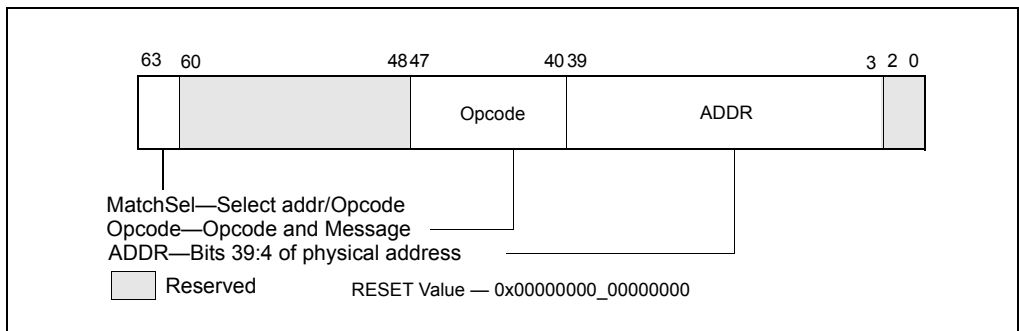
- EN (bit 0): When clear, the uncore fixed-function counter is locally disabled. When set, it is locally enabled and counting starts when the EN\_FC0 bit in MSR\_UNCORE\_PERF\_GLOBAL\_CTRL is set.
- PMI (bit 2): When set, the uncore will generate an interrupt request when the uncore fixed-function counter overflowed. This request will be routed to the logical processors as enabled in the PMI enable bits (EN\_PMI\_COREx) in the register MSR\_UNCORE\_PERF\_GLOBAL\_CTRL.

Both the general-purpose counters (MSR\_UNCORE\_PerfCtr) and the fixed-function counter (MSR\_UNCORE\_FixedCtr0) are 48 bits wide. They support both counting

and sampling usages. The event logic unit can filter event counts to specific regions of code or transaction types incoming to the home node logic.

### 18.6.2.3 Uncore Address/Opcode Match MSR

The Event Select field [7:0] of MSR\_UNCORE\_PERFEVTSELx is used to select different uncore event logic unit. When the event "ADDR\_OPCODE\_MATCH" is selected in the Event Select field, software can filter uncore performance events according to transaction address and certain transaction responses. The address filter and transaction response filtering requires the use of MSR\_UNCORE\_ADDR\_OPCODE\_MATCH register. The layout is shown in Figure 18-23.



**Figure 18-23. Layout of MSR\_UNCORE\_ADDR\_OPCODE\_MATCH MSR**

- Addr (bits 39:3): The physical address to match if "MatchSel" field is set to select address match. The uncore performance counter will increment if the lowest 40-bit incoming physical address (excluding bits 2:0) for a transaction request matches bits 39:3.
- Opcode (bits 47:40) : Bits 47:40 allow software to filter uncore transactions based on QPI link message class/packed header opcode. These bits are consists two sub-fields:
  - Bits 43:40 specify the QPI packet header opcode,
  - Bits 47:44 specify the QPI message classes.

Table 18-16 lists the encodings supported in the opcode field.

**Table 18-16. Opcode Field Encoding for MSR\_UNCORE\_ADDR\_OPCODE\_MATCH**

Opcode [43:40]	QPI Message Class		
		Home Request [47:44] = 0000B	Snoop Response [47:44] = 0001B

**Table 18-16. Opcode Field Encoding for MSR\_UNCORE\_ADDR\_OPCODE\_MATCH**

Opcode [43:40]	QPI Message Class		
		1	
DMND_IFETCH	2	2	
WB	3	3	
PF_DATA_RD	4	4	
PF_RFO	5	5	
PF_IFETCH	6	6	
OTHER	7	7	
NON_DRAM	15	15	

- MatchSel (bits 63:61): Software specifies the match criteria according to the following encoding:
  - 000B: Disable addr\_opcode match hardware
  - 100B: Count if only the address field matches,
  - 010B: Count if only the opcode field matches
  - 110B: Count if either opcode field matches or the address field matches
  - 001B: Count only if both opcode and address field match
  - Other encoding are reserved

### 18.6.3 Intel® Xeon® Processor 7500 Series Performance Monitoring Facility

The performance monitoring facility in the processor core of Intel® Xeon® processor 7500 series are the same as those supported in Intel Xeon processor 5500 series. The uncore subsystem in Intel Xeon processor 7500 series are significantly different. The uncore performance monitoring facility consist of many distributed units associated with individual logic control units (referred to as boxes) within the uncore subsystem. A high level block diagram of the various box units of the uncore is shown in Figure 18-24.

Uncore PMUs are programmed via MSR interfaces. Each of the distributed uncore PMU units have several general-purpose counters. Each counter requires an associated event select MSR, and may require additional MSRs to configure sub-event conditions. The uncore PMU MSRs associated with each box can be categorized based on its functional scope: per-counter, per-box, or global across the uncore. The number counters available in each box type are different. Each box generally provides a set of MSRs to enable/disable, check status/overflow of multiple counters within each box.

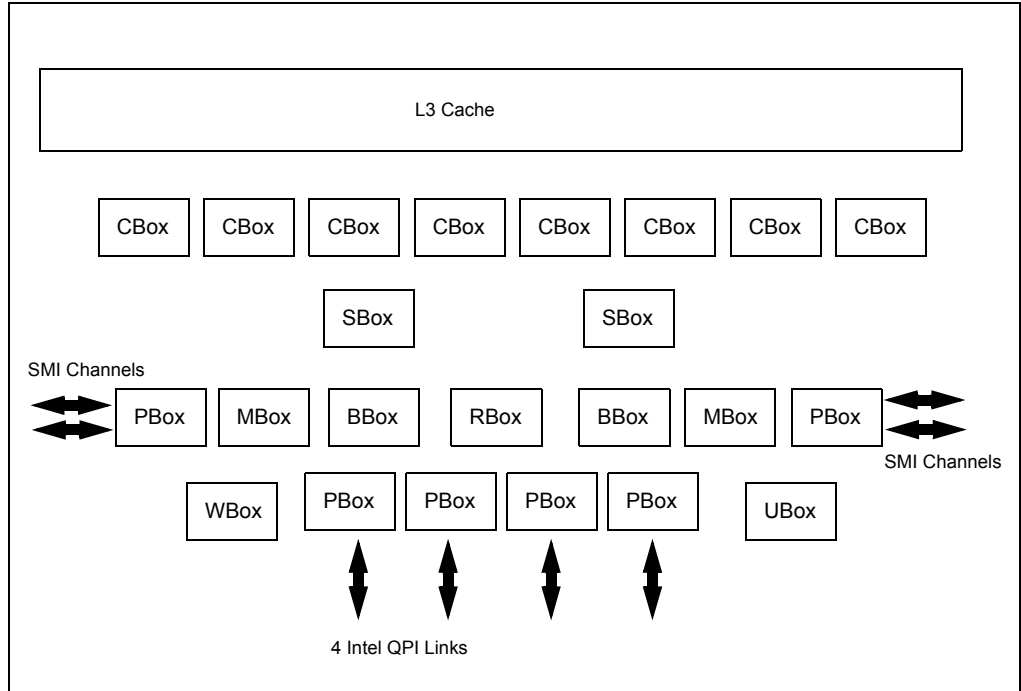


Figure 18-24. Distributed Units of the Uncore of Intel® Xeon® Processor 7500 Series

Table 18-17 summarizes the number MSRs for uncore PMU for each box.

Table 18-17. Uncore PMU MSR Summary

Box	# of Boxes	Counters per Box	Counter Width	General Purpose	Global Enable	Sub-control MSRs
C-Box	8	6	48	Yes	per-box	None
S-Box	2	4	48	Yes	per-box	Match/Mask
B-Box	2	4	48	Yes	per-box	Match/Mask
M-Box	2	6	48	Yes	per-box	Yes
R-Box	1	16 ( 2 port, 8 per port)	48	Yes	per-box	Yes
W-Box	1	4	48	Yes	per-box	None
		1	48	No	per-box	None
U-Box	1	1	48	Yes	uncore	None

The W-Box provides 4 general-purpose counters, each requiring an event select configuration MSR, similar to the general-purpose counters in other boxes. There is also a fixed-function counter that increments clockticks in the uncore clock domain.

For C,S,B,M,R, and W boxes, each box provides an MSR to enable/disable counting, configuring PMI of multiple counters within the same box, this is somewhat similar the "global control" programming interface, IA32\_PERF\_GLOBAL\_CTRL, offered in the core PMU. Similarly status information and counter overflow control for multiple counters within the same box are also provided in C,S,B,M,R, and W boxes.

In the U-Box, MSR\_U\_PMON\_GLOBAL\_CTL provides overall uncore PMU enable/disable and PMI configuration control. The scope of status information in the U-box is at per-box granularity, in contrast to the per-box status information MSR (in the C,S,B,M,R, and W boxes) providing status information of individual counter overflow. The difference in scope also apply to the overflow control MSR in the U-Box versus those in the other Boxes.

The individual MSRs that provide uncore PMU interfaces are listed in Chapter 34, Table 34-7 under the general naming style of MSR\_%box#%\_PMON\_%scope\_function%, where %box#% designates the type of box and zero-based index if there are more than one box of the same type, %scope\_function% follows the examples below:

- Multi-counter enabling MSRs: MSR\_U\_PMON\_GLOBAL\_CTL, MSR\_S0\_PMON\_BOX\_CTL, MSR\_C7\_PMON\_BOX\_CTL, etc.
- Multi-counter status MSRs: MSR\_U\_PMON\_GLOBAL\_STATUS, MSR\_S0\_PMON\_BOX\_STATUS, MSR\_C7\_PMON\_BOX\_STATUS, etc.
- Multi-counter overflow control MSRs: MSR\_U\_PMON\_GLOBAL\_OVF\_CTL, MSR\_S0\_PMON\_BOX\_OVF\_CTL, MSR\_C7\_PMON\_BOX\_OVF\_CTL, etc.
- Performance counters MSRs: the scope is implicitly per counter, e.g. MSR\_U\_PMON\_CTR, MSR\_S0\_PMON\_CTR0, MSR\_C7\_PMON\_CTR5, etc
- Event select MSRs: the scope is implicitly per counter, e.g. MSR\_U\_PMON\_EVNT\_SEL, MSR\_S0\_PMON\_EVNT\_SEL0, MSR\_C7\_PMON\_EVNT\_SEL5, etc
- Sub-control MSRs: the scope is implicitly per-box granularity, e.g. MSR\_M0\_PMON\_TIMESTAMP, MSR\_R0\_PMON\_IPERF0\_P1, MSR\_S1\_PMON\_MATCH.

Details of uncore PMU MSR bit field definitions can be found in a separate document "Intel Xeon Processor 7500 Series Uncore Performance Monitoring Guide".

## 18.7 PERFORMANCE MONITORING FOR PROCESSORS BASED ON INTEL® MICROARCHITECTURE CODE NAME WESTMERE

All of the performance monitoring programming interfaces (architectural and non-architectural core PMU facilities, and uncore PMU) described in Section 18.6 also apply to processors based on Intel® microarchitecture code name Westmere.

Table 18-14 describes a non-architectural performance monitoring event (event code 0B7H) and associated MSR\_OFFCORE\_RSP\_0 (address 1A6H) in the core PMU. This event and a second functionally equivalent offcore response event using event code 0BBH and MSR\_OFFCORE\_RSP\_1 (address 1A7H) are supported in processors based on Intel microarchitecture code name Westmere. The event code and event mask definitions of Non-architectural performance monitoring events are listed in Table 19-14.

The load latency facility is the same as described in Section 18.6.1.2, but added enhancement to provide more information in the data source encoding field of each load latency record. The additional information relates to STLB\_MISS and LOCK, see Table 18-22.

### 18.7.1 Intel® Xeon® Processor E7 Family Performance Monitoring Facility

The performance monitoring facility in the processor core of the Intel® Xeon® processor E7 family is the same as those supported in the Intel Xeon processor 5600 series<sup>2</sup>. The uncore subsystem in the Intel Xeon processor E7 family is similar to those of the Intel Xeon processor 7500 series. The high level construction of the uncore sub-system is similar to that shown in Figure 18-24, with the additional capability that up to 10 C-Box units are supported.

Table 18-18 summarizes the number MSRs for uncore PMU for each box.

**Table 18-18. Uncore PMU MSR Summary for Intel® Xeon® Processor E7 Family**

Box	# of Boxes	Counters per Box	Counter Width	General Purpose	Global Enable	Sub-control MSRs
C-Box	10	6	48	Yes	per-box	None
S-Box	2	4	48	Yes	per-box	Match/Mask
B-Box	2	4	48	Yes	per-box	Match/Mask
M-Box	2	6	48	Yes	per-box	Yes

2. Exceptions are indicated for event code 0FH in .Table 19-9; and valid bits of data source encoding field of each load latency record is limited to bits 5:4 of Table 18-22.

**Table 18-18. Uncore PMU MSR Summary for Intel® Xeon® Processor E7 Family**

Box	# of Boxes	Counters per Box	Counter Width	General Purpose	Global Enable	Sub-control MSRs
R-Box	1	16 ( 2 port, 8 per port)	48	Yes	per-box	Yes
W-Box	1	4	48	Yes	per-box	None
		1	48	No	per-box	None
U-Box	1	1	48	Yes	uncore	None

## 18.8 PERFORMANCE MONITORING FOR PROCESSORS BASED ON INTEL® MICROARCHITECTURE CODE NAME SANDY BRIDGE

Intel® Core™ i7-2xxx, Intel® Core™ i5-2xxx, Intel® Core™ i3-2xxx processor series are based on Intel microarchitecture code name Sandy Bridge; this section describes the performance monitoring facilities provided in the processor core. The core PMU supports architectural performance monitoring capability with version ID 3 (see Section 18.2.2.2) and a host of non-architectural monitoring capabilities.

Architectural performance monitoring events and non-architectural monitoring events are programmed using fixed counters and programmable counters/event select MSRS described in Section 18.2.2.2.

The core PMU's capability is similar to those described in Section 18.6.1 and Section 18.7, with some differences and enhancements relative to Intel microarchitecture code name Westmere summarized in Table 18-19.

**Table 18-19. Core PMU Comparison**

Box	Sandy Bridge	Westmere	Comment
# of Fixed counters per thread	3	3	Use CPUID to enumerate # of counters.
# of general-purpose counters per core	8	8	
Counter width (R,W)	R:48 , W: 32/48	R:48, W:32	See Section 18.2.2.3.
# of programmable counters per thread	4 or (8 if a core not shared by two threads)	4	Use CPUID to enumerate # of counters.
Precise Event Based Sampling (PEBS) Events	See Table 18-21	See Table 18-10	IA32_PMC4-IA32_PMC7 do not support PEBS.

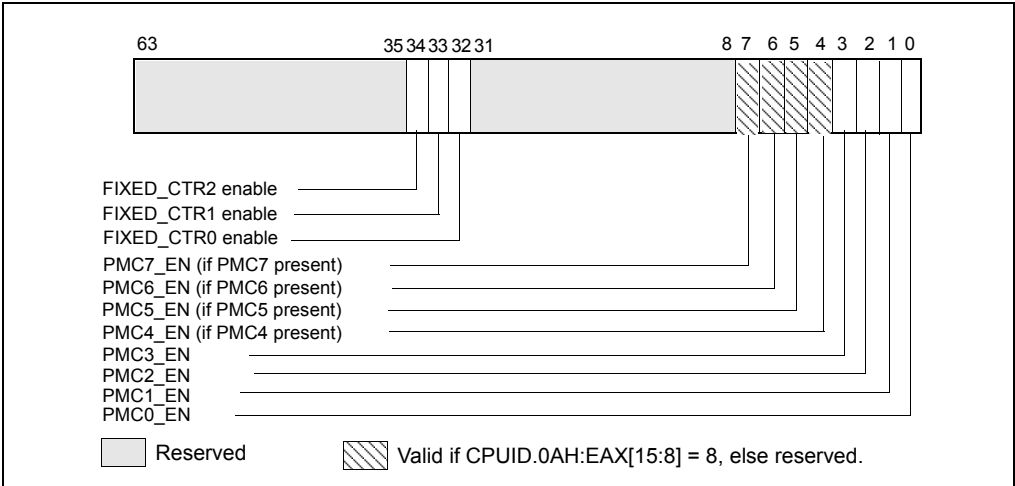


**Table 18-19. Core PMU Comparison**

Box	Sandy Bridge	Westmere	Comment
PEBS-Load Latency	See Section 18.8.4.2; Data source encoding, STLB miss encoding, Lock transaction encoding	Data source encoding	
PEBS-Precise Store	Section 18.8.4.3	No	
PEBS-PDIR	yes (using precise INST_RETIRED.ALL)	No	
Off-core Response Event	MSR 1A6H and 1A7H; Extended request and response types	MSR 1A6H and 1A7H, limited response types	Nehalem supports 1A6H only.

### 18.8.1 Global Counter Control Facilities In Intel® Microarchitecture Code Name Sandy Bridge

The number of general-purpose performance counters visible to a logical processor can vary across Processors based on Intel microarchitecture code name Sandy Bridge. Software must use CPUID to determine the number performance counters/event select registers (See Section 18.2.1.1).

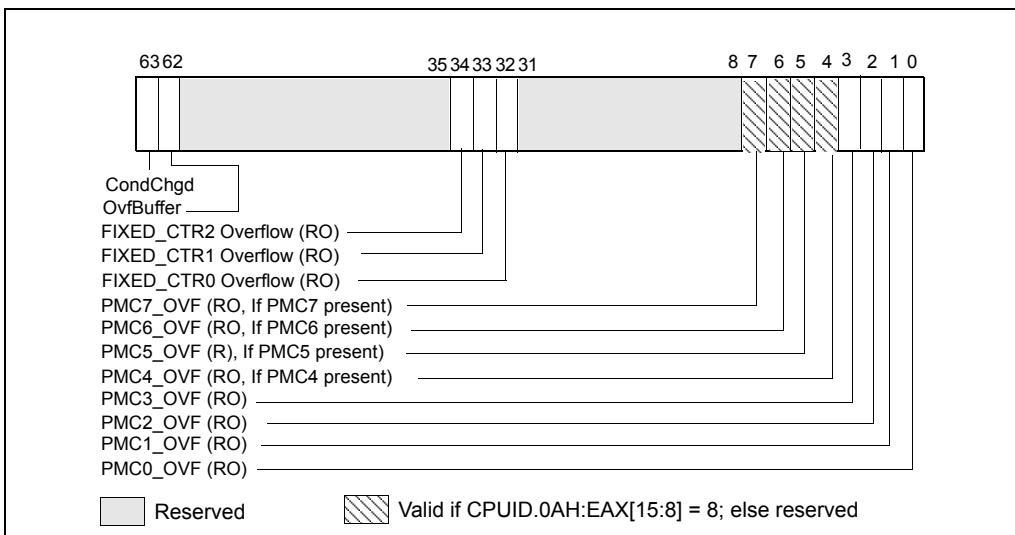


**Figure 18-25. IA32\_PERF\_GLOBAL\_CTRL MSR in Intel® Microarchitecture Code Name Sandy Bridge**

Figure 18-10 depicts the layout of IA32\_PERF\_GLOBAL\_CTRL MSR. The enable bits (PMC4\_EN, PMC5\_EN, PMC6\_EN, PMC7\_EN) corresponding to IA32\_PMC4-IA32\_PMC7 are valid only if CPUID.0AH:EAX[15:8] reports a value of '8'. If CPUID.0AH:EAX[15:8] = 4, attempts to set the invalid bits will cause #GP.

Each enable bit in IA32\_PERF\_GLOBAL\_CTRL is AND'ed with the enable bits for all privilege levels in the respective IA32\_PERFEVTSELx or IA32\_PERF\_FIXED\_CTR\_CTRL MSRs to start/stop the counting of respective counters. Counting is enabled if the AND'ed results is true; counting is disabled when the result is false.

IA32\_PERF\_GLOBAL\_STATUS MSR provides single-bit status used by software to query the overflow condition of each performance counter. The MSR also provides additional status bit to indicate overflow conditions when counters are programmed for precise-event-based sampling (PEBS). The IA32\_PERF\_GLOBAL\_STATUS MSR also provides a 'sticky bit' to indicate changes to the state of performance monitoring hardware (see Figure 18-26). A value of 1 in each bit of the PMCx\_OVF field indicates an overflow condition has occurred in the associated counter.



**Figure 18-26. IA32\_PERF\_GLOBAL\_STATUS MSR in Intel® Microarchitecture Code Name Sandy Bridge**

When a performance counter is configured for PEBS, an overflow condition in the counter generates a performance-monitoring interrupt this signals a PEBS event. On a PEBS event, the processor stores data records in the buffer area (see Section 17.4.9), clears the counter overflow status, and sets the OvfBuffer bit in IA32\_PERF\_GLOBAL\_STATUS.

IA32\_PERF\_GLOBAL\_OVF\_CTL MSR allows software to clear overflow the indicators for general-purpose or fixed-function counters via a single WRMSR (see Figure 18-27). Clear overflow indications when:

- Setting up new values in the event select and/or UMASK field for counting or sampling
- Reloading counter values to continue sampling
- Disabling event counting or sampling

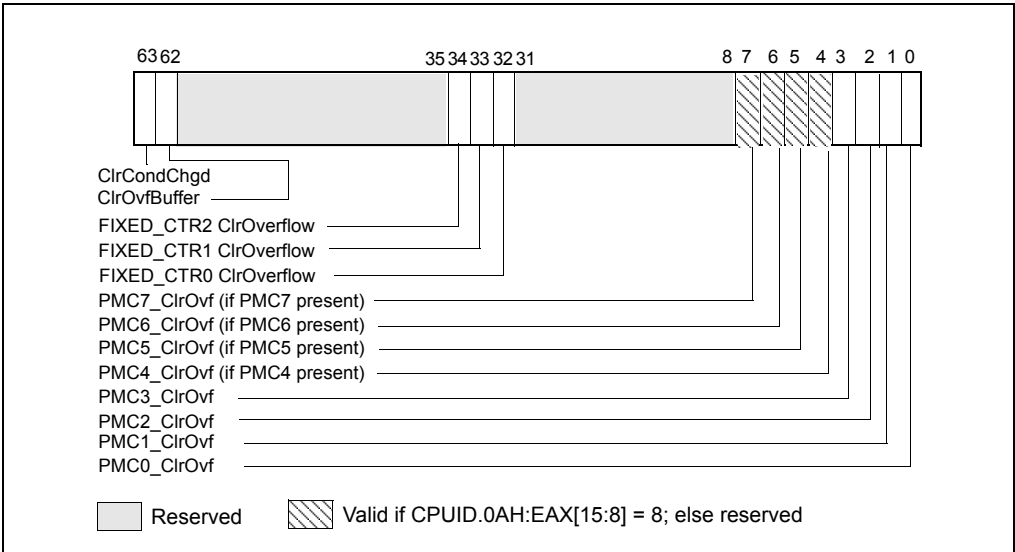


Figure 18-27. IA32\_PERF\_GLOBAL\_OVF\_CTL MSR in Intel microarchitecture code name Sandy Bridge

### 18.8.2 Counter Coalescence

In processors based on Intel microarchitecture code name Sandy Bridge, each processor core implements eight general-purpose counters. CPUID.0AH:EAX[15:8] will report either 4 or 8 depending specific processor’s product features.

If a processor core is shared by two logical processors, each logical processors can access 4 counters (IA32\_PMC0-IA32\_PMC3). This is the same as in the prior generation for processors based on Intel microarchitecture code name Nehalem.

If a processor core is not shared by two logical processors, all eight general-purpose counters are visible, and CPUID.0AH:EAX[15:8] reports 8. IA32\_PMC4-IA32\_PMC7 occupy MSR addresses 0C5H through 0C8H. Each counter is accompanied by an event select MSR (IA32\_PERFEVTSEL4-IA32\_PERFEVTSEL7).

If CPUID.0AH:EAX[15:8] report 4, access to IA32\_PMC4-IA32\_PMC7, IA32\_PMC4-IA32\_PMC7 will cause #GP. Writing 1's to bit position 7:4 of IA32\_PERF\_GLOBAL\_CTRL, IA32\_PERF\_GLOBAL\_STATUS, or IA32\_PERF\_GLOBAL\_OVF\_CTL will also cause #GP.

### 18.8.3 Full Width Writes to Performance Counters

Processors based on Intel microarchitecture code name Sandy Bridge support full-width writes to the general-purpose counters, IA32\_PMCx. Support of full-width writes are enumerated by IA32\_PERF\_CAPABILITIES.FW\_WRITES[13] (see Section 18.2.2.3).

The default behavior of IA32\_PMCx is unchanged, i.e. WRMSR to IA32\_PMCx results in a sign-extended 32-bit value of the input EAX written into IA32\_PMCx. Full-width writes must issue WRMSR to a dedicated alias MSR address for each IA32\_PMCx.

Software must check the presence of full-width write capability and the presence of the alias address IA32\_A\_PMCx by testing IA32\_PERF\_CAPABILITIES[13].

### 18.8.4 PEBS Support in Intel® Microarchitecture Code Name Sandy Bridge

Processors based on Intel microarchitecture code name Sandy Bridge support PEBS, similar to those offered in prior generation, with several enhanced features. The key components and differences of PEBS facility relative to Intel microarchitecture code name Westmere is summarized in Table 18-20.

**Table 18-20. PEBS Facility Comparison**

Box	Sandy Bridge	Westmere	Comment
Valid IA32_PMCx	PMC0-PMC3	PMC0-PMC3	No PEBS on PMC4-PMC7
PEBS Buffer Programming	Section 18.6.1.1	Section 18.6.1.1	Unchanged
IA32_PEBS_ENABLE Layout	Figure 18-28	Figure 18-14	
PEBS record layout	Physical Layout same as Table 18-12	Table 18-12	Enhanced fields at offsets 98H, A0H, A8H
PEBS Events	See Table 18-21	See Table 18-10	IA32_PMC4-IA32_PMC7 do not support PEBS.
PEBS-Load Latency	See Table 18-22	Table 18-13	
PEBS-Precise Store	yes; see Section 18.8.4.3	No	IA32_PMC3 only
PEBS-PDIR	yes	No	IA32_PMC1 only

**Table 18-20. PEBS Facility Comparison**

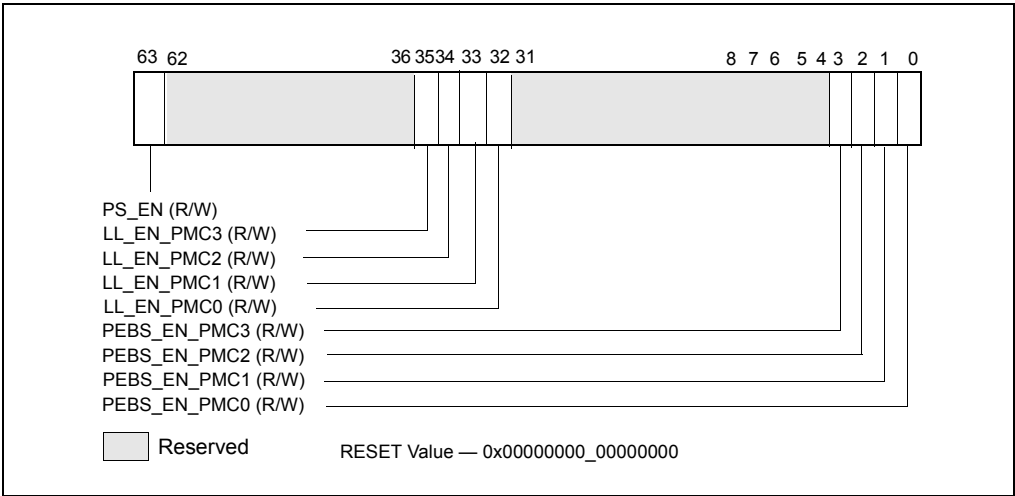
Box	Sandy Bridge	Westmere	Comment
SAMPLING Restriction	Small SAV(CountDown) value incur higher overhead than prior generation.		

Only IA32\_PMC0 through IA32\_PMC3 support PEBS.

**NOTE**

PEBS events are only valid when the following fields of IA32\_PERFEVTSELx are all zero: AnyThread, Edge, Invert, CMask.

In IA32\_PEBS\_ENABLE MSR, bit 63 is defined as PS\_ENABLE: When set, this enables IA32\_PMC3 to capture precise store information. Only IA32\_PMC3 supports the precise store facility. In typical usage of PEBS, the bit fields in IA32\_PEBS\_ENABLE are written to when the agent software starts PEBS operation; the enabled bit fields should be modified only when re-programming another PEBS event or cleared when the agent uses the performance counters for non-PEBS operations.



**Figure 18-28. Layout of IA32\_PEBS\_ENABLE MSR**

**18.8.4.1 PEBS Record Format**

The layout of PEBS records physically identical to those shown in Table 18-12, but the fields at offset 98H, A0H and A8H have been enhanced to support additional PEBS capabilities.

- Load/Store Data Linear Address (Offset 98H): This field will contain the linear address of the source of the load, or linear address of the destination of the store.

- **Data Source /Store Status (Offset A0H):**When load latency is enabled, this field will contain three piece of information (including an encoded value indicating the source which satisfied the load operation). The source field encodings are detailed in Table 18-13. When precise store is enabled, this field will contain information indicating the status of the store, as detailed in Table 19.
- **Latency Value/0 (Offset A8H):** When load latency is enabled, this field contains the latency in cycles to service the load. This field is not meaningful when precise store is enabled and will be written to zero in that case. Upon writing the PEBS record, microcode clears the overflow status bits in the IA32\_PERF\_GLOBAL\_STATUS corresponding to those counters that both overflowed and were enabled in the IA32\_PEBS\_ENABLE register. The status bits of other counters remain unaffected.

The number PEBS events has expanded. The list of PEBS events supported in Intel microarchitecture code name Sandy Bridge is shown in Table 18-21.

**Table 18-21. PEBS Performance Events for Intel® Microarchitecture Code Name Sandy Bridge**

Event Name	Event Select	Sub-event	UMask
INST_RETIRED	C0H	PREC_DIST	01H <sup>1</sup>
UOPS_RETIRED	C2H	All	01H
		Retire_Slots	02H
BR_INST_RETIRED	C4H	Conditional	01H
		Near_Call	02H
		All_branches	04H
		Near_Return	08H
		Not_Taken	10H
		Near_Taken	20H
BR_MISP_RETIRED	C5H	Conditional	01H
		Near_Call	02H
		All_branches	04H
		Not_Taken	10H
		Taken	20H
MEM_TRANS_RETIRED	CDH	Load_Latency	01H
		Precise_Store	02H

**Table 18-21. PEBS Performance Events for Intel® Microarchitecture Code Name Sandy Bridge (Contd.)**

Event Name	Event Select	Sub-event	UMask
MEM_UOP_RETIRED	D0H	Load	01H
		Store	02H
		STLB_Miss	10H
		Lock	20H
		SPLIT	40H
		ALL	80H
MEM_LOAD_UOPS_RETIRED	D1H	L1_Hit	01H
		L2_Hit	02H
		L3_Hit	04H
		Hit_LFB	40H
MEM_LOAD_UOPS_LLC_HIT_RETIRED	D2H	XSNP_Miss	01H
		XSNP_Hit	02H
		XSNP_Hitm	04H
		XSNP_None	08H
MEM_LOAD_UOPS_MISC_RETIRED	D4H	LLC_Miss	02H

**NOTES:**

1. Only available on IA32\_PMC1.

### 18.8.4.2 Load Latency Performance Monitoring Facility

The load latency facility in Intel microarchitecture code name Sandy Bridge is similar to that in prior microarchitecture. It provides software a means to characterize the average load latency to different levels of cache/memory hierarchy. This facility requires processor supporting enhanced PEBS record format in the PEBS buffer, see Table 18-12 and Section 18.8.4.1. The facility measures latency from micro-operation (uop) dispatch to when data is globally observable (GO).

To use this feature software must assure:

- One of the IA32\_PERFEVTSELx MSR is programmed to specify the event unit MEM\_TRANS\_RETIRED, and the LATENCY\_ABOVE\_THRESHOLD event mask must be specified (IA32\_PerfEvtSelX[15:0] = 0x1CDH). The corresponding counter IA32\_PMCx will accumulate event counts for architecturally visible loads which exceed the programmed latency threshold specified separately in a MSR. Stores are ignored when this event is programmed. The CMASK or INV fields of the IA32\_PerfEvtSelX register used for counting load latency must be 0. Writing other values will result in undefined behavior.

- The MSR\_PEBS\_LD\_LAT\_THRESHOLD MSR is programmed with the desired latency threshold in core clock cycles. Loads with latencies greater than this value are eligible for counting and latency data reporting. The minimum value that may be programmed in this register is 3 (the minimum detectable load latency is 4 core clock cycles).
- The PEBS enable bit in the IA32\_PEBS\_ENABLE register is set for the corresponding IA32\_PMCx counter register. This means that both the PEBS\_EN\_CTRX and LL\_EN\_CTRX bits must be set for the counter(s) of interest. For example, to enable load latency on counter IA32\_PMC0, the IA32\_PEBS\_ENABLE register must be programmed with the 64-bit value 0x00000001.00000001.
- When Load latency event is enabled, no other PEBS event can be configured with other counters.

When the load-latency facility is enabled, load operations are randomly selected by hardware and tagged to carry information related to data source locality and latency. Latency and data source information of tagged loads are updated internally. The MEM\_TRANS\_RETIRED event for load latency counts only tagged retired loads. If a load is cancelled it will not be counted and the internal state of the load latency facility will not be updated. In this case the hardware will tag the next available load.

When a PEBS assist occurs, the last update of latency and data source information are captured by the assist and written as part of the PEBS record. The PEBS sample after value (SAV), specified in PEBS CounterX Reset, operates orthogonally to the tagging mechanism. Loads are randomly tagged to collect latency data. The SAV controls the number of tagged loads with latency information that will be written into the PEBS record field by the PEBS assists. The load latency data written to the PEBS record will be for the last tagged load operation which retired just before the PEBS assist was invoked.

The physical layout of the PEBS records is the same as shown in Table 18-12. The specificity of Data Source entry at offset A0H has been enhanced to report three piece of information.

**Table 18-22. Layout of Data Source Field of Load Latency Record**

Field	Position	Description
Source	3:0	See Table 18-13
STLB_MISS	4	0: The load did not miss the STLB (hit the DTLB or STLB). 1: The load missed the STLB.
Lock	5	0: The load was not part of a locked transaction. 1: The load was part of a locked transaction.
Reserved	63:6	

The layout of MSR\_PEBS\_LD\_LAT\_THRESHOLD is the same as shown in Figure 18-16.



### 18.8.4.3 Precise Store Facility

Processors based on Intel microarchitecture code name Sandy Bridge offer a precise store capability that complements the load latency facility. It provides a means to profile store memory references in the system.

Precise stores leverage the PEBS facility and provide additional information about sampled stores. Having precise memory reference events with linear address information for both loads and stores can help programmers improve data structure layout, eliminate remote node references, and identify cache-line conflicts in NUMA systems.

Only IA32\_PMC3 can be used to capture precise store information. After enabling this facility, counter overflows will initiate the generation of PEBS records as previously described in PEBS. Upon counter overflow hardware captures the linear address and other status information of the next store that retires. This information is then written to the PEBS record.

To enable the precise store facility, software must complete the following steps. Please note that the precise store facility relies on the PEBS facility, so the PEBS configuration requirements must be completed before attempting to capture precise store information.

- Complete the PEBS configuration steps.
- Program the MEM\_TRANS\_RETIRED.PRECISE\_STORE event in IA32\_PERFEVTSEL3. Only counter 3 (IA32\_PMC3) supports collection of precise store information.
- Set IA32\_PEBS\_ENABLE[3] and IA32\_PEBS\_ENABLE[63]. This enables IA32\_PMC3 as a PEBS counter and enables the precise store facility, respectively.

The precise store information written into a PEBS record affects entries at offset 98H, A0H and A8H of Table 18-12. The specificity of Data Source entry at offset A0H has been enhanced to report three piece of information.

**Table 18-23. Layout of Precise Store Information In PEBS Record**

Field	Offset	Description
Store Data Linear Address	98H	The linear address of the destination of the store.
Store Status	A0H	<p><b>DCU Hit</b> (Bit 0): The store hit the data cache closest to the core (lowest latency cache) if this bit is set, otherwise the store missed the data cache.</p> <p><b>STLB Miss</b> (bit 4): The store missed the STLB if set, otherwise the store hit the STLB</p> <p><b>Locked Access</b> (bit 5): The store was part of a locked access if set, otherwise the store was not part of a locked access.</p>
Reserved	A8H	Reserved

### 18.8.4.4 Precise Distribution of Instructions Retired (PDIR)

Upon triggering a PEBS assist, there will be a finite delay between the time the counter overflows and when the microcode starts to carry out its data collection obligations. INST\_RETIREED is a very common event that is used to sample where performance bottleneck happened and to help identify its location in instruction address space. Even if the delay is constant in core clock space, it invariably manifest as variable “skids” in instruction address space. This creates a challenge for programmers to profile a workload and pinpoint the location of bottlenecks.

The core PMU in processors based on Intel microarchitecture code name Sandy Bridge include a facility referred to as precise distribution of Instruction Retired (PDIR).

The PDIR facility mitigates the “skid” problem by providing an early indication of when the INST\_RETIREED counter is about to overflow, allowing the machine to more precisely trap on the instruction that actually caused the counter overflow thus eliminating skid.

PDIR applies only to the INST\_RETIREED.PREC\_DIST precise event, and must use IA32\_PMC1 with PerfEvtSel1 property configured and bit 1 in the IA32\_PEBS\_ENABLE set to 1. INST\_RETIREED.PREC\_DIST is a non-architectural performance event, it is not supported in prior generation microarchitectures. Additionally, current implementation of PDIR limits tool to quiesce the rest of the programmable counters in the core when PDIR is active.

## 18.8.5 Off-core Response Performance Monitoring

The core PMU in processors based on Intel microarchitecture code name Sandy Bridge provides off-core response facility similar to prior generation. Off-core response can be programmed only with a specific pair of event select and counter MSR, and with specific event codes and predefine mask bit value in a dedicated MSR to specify attributes of the off-core transaction. Two event codes are dedicated for off-core response event programming. Each event code for off-core response monitoring requires programming an associated configuration MSR, MSR\_OFFCORE\_RSP\_x. Table 18-24 lists the event code, mask value and additional off-core configuration MSR that must be programmed to count off-core response events using IA32\_PMCx.

**Table 18-24. Off-Core Response Event Encoding**

Counter	Event code	UMask	Required Off-core Response MSR
PMC0	0xB7	0x01	MSR_OFFCORE_RSP_0 (address 0x1A6)
PMC3	0xBB	0x01	MSR_OFFCORE_RSP_1 (address 0x1A7)

The layout of MSR\_OFFCORE\_RSP\_0 and MSR\_OFFCORE\_RSP\_1 are shown in Figure 18-29 and Figure 18-30. Bits 15:0 specifies the request type of a transaction

request to the uncore. Bits 30:16 specifies supplier information, bits 37:31 specifies snoop response information.

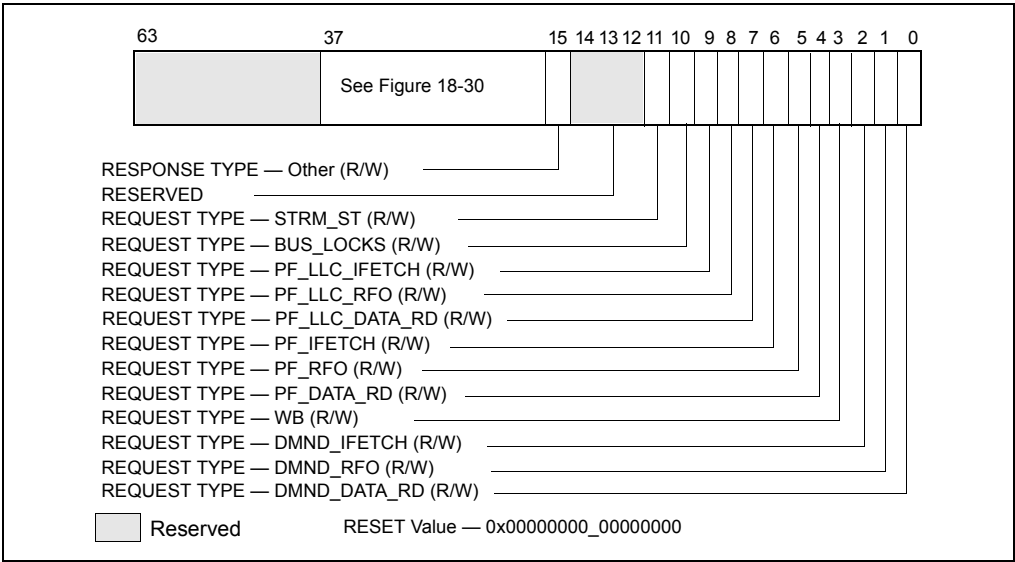


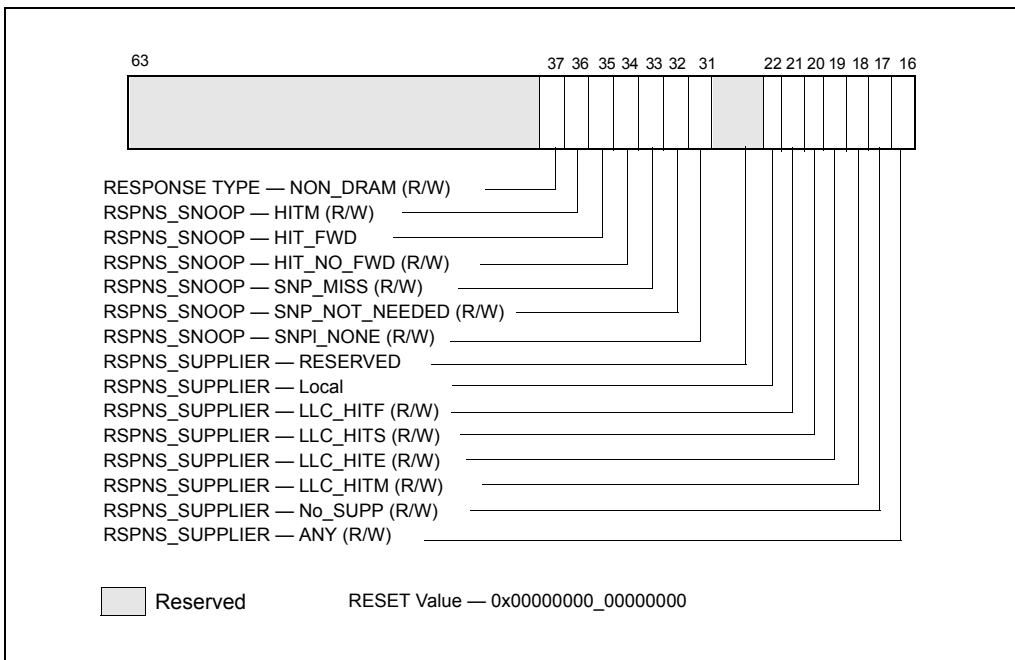
Figure 18-29. Request\_Type Fields for MSR\_OFFCORE\_RSP\_x

Table 18-25. MSR\_OFFCORE\_RSP\_x Request\_Type Field Definition

Bit Name	Offset	Description
DMND_DATA_RD	0	(R/W). Counts the number of demand and DCU prefetch data reads of full and partial cachelines as well as demand data page table entry cacheline reads. Does not count L2 data read prefetches or instruction fetches.
DMND_RFO	1	(R/W). Counts the number of demand and DCU prefetch reads for ownership (RFO) requests generated by a write to data cacheline. Does not count L2 RFO prefetches.
DMND_IFETCH	2	(R/W). Counts the number of demand and DCU prefetch instruction cacheline reads. Does not count L2 code read prefetches.
WB	3	(R/W). Counts the number of writeback (modified to exclusive) transactions.
PF_DATA_RD	4	(R/W). Counts the number of data cacheline reads generated by L2 prefetchers.
PF_RFO	5	(R/W). Counts the number of RFO requests generated by L2 prefetchers.

**Table 18-25. MSR\_OFFCORE\_RSP\_x Request\_Type Field Definition (Contd.)**

Bit Name	Offset	Description
PF_IFETCH	6	(R/W). Counts the number of code reads generated by L2 prefetchers.
PF_LLC_DATA_RD	7	(R/W). L2 prefetcher to L3 for loads.
PF_LLC_RFO	8	(R/W). RFO requests generated by L2 prefetcher
PF_LLC_IFETCH	9	(R/W). L2 prefetcher to L3 for instruction fetches.
BUS_LOCKS	10	(R/W). Bus lock and split lock requests
STRM_ST	11	(R/W). Streaming store requests
OTHER	15	(R/W). Any other request that crosses IDI, including I/O.



**Figure 18-30. Response\_Supplier and Snoop Info Fields for MSR\_OFFCORE\_RSP\_x**

To properly program this extra register, software must set at least one request type bit and a valid response type pattern. Otherwise, the event count reported will be zero. It is permissible and useful to set multiple request and response type bits in order to obtain various classes of off-core response events. Although MSR\_OFFCORE\_RSP\_x allow an agent software to program numerous combinations that meet the above guideline, not all combinations produce meaningful data.

**Table 18-26. MSR\_OFFCORE\_RSP\_x Response Supplier Info Field Definition**

Subtype	Bit Name	Offset	Description
Common	Any	16	(R/W). Catch all value for any response types.
Supplier Info	NO_SUPP	17	(R/W). No Supplier Information available
	LLC_HITM	18	(R/W). M-state initial lookup stat in L3.
	LLC_HITE	19	(R/W). E-state
	LLC_HITS	20	(R/W). S-state
	LLC_HITF	21	(R/W). F-state
	LOCAL	22	(R/W). Local DRAM Controller
	Reserved	30:23	Reserved

To specify a complete offcore response filter, software must properly program bits in the request and response type fields. A valid request type must have at least one bit set in the non-reserved bits of 15:0. A valid response type must be a non-zero value of the following expression:

ANY | [(‘OR’ of Supplier Info Bits) & (‘OR’ of Snoop Info Bits)]

If “ANY” bit is set, the supplier and snoop info bits are ignored.

**Table 18-27. MSR\_OFFCORE\_RSP\_x Snoop Info Field Definition**

Subtype	Bit Name	Offset	Description
Snoop Info	SNP_NONE	31	(R/W). No details on snoop-related information
	SNP_NOT_NEEDED	32	(R/W). No snoop was needed to satisfy the request.
	SNP_MISS	33	(R/W). A snoop was needed and it missed all snooped caches: -For LLC Hit, ReslHitl was returned by all cores -For LLC Miss, Rspl was returned by all sockets and data was returned from DRAM.

**Table 18-27. MSR\_OFFCORE\_RSP\_x Snoop Info Field Definition (Contd.)**

Subtype	Bit Name	Offset	Description
	SNP_NO_FWD	34	(R/W). A snoop was needed and it hits in at least one snooped cache. Hit denotes a cache-line was valid before snoop effect. This includes: -Snoop Hit w/ Invalidation (LLC Hit, RFO) -Snoop Hit, Left Shared (LLC Hit/Miss, IFetch/Data_RD) -Snoop Hit w/ Invalidation and No Forward (LLC Miss, RFO Hit S) In the LLC Miss case, data is returned from DRAM.
	SNP_FWD	35	(R/W). A snoop was needed and data was forwarded from a remote socket. This includes: -Snoop Forward Clean, Left Shared (LLC Hit/Miss, IFetch/Data_RD/RFT).
	HITM	36	(R/W). A snoop was needed and it HitM-ed in local or remote cache. HitM denotes a cache-line was in modified state before effect as a results of snoop. This includes: -Snoop HitM w/ WB (LLC miss, IFetch/Data_RD) -Snoop Forward Modified w/ Invalidation (LLC Hit/Miss, RFO) -Snoop MtoS (LLC Hit, IFetch/Data_RD).
	NON_DRAM	37	(R/W). Target was non-DRAM system address. This includes MMIO transactions.

### 18.8.6 Uncore Performance Monitoring Facilities In Intel® Core™ i7-2xxx, Intel® Core™ i5-2xxx, Intel® Core™ i3-2xxx Processor Series

The uncore sub-system in Intel® Core™ i7-2xxx, Intel® Core™ i5-2xxx, Intel® Core™ i3-2xxx processor series provides a unified L3 that can support up to four processor cores. The L3 cache consists multiple slices, each slice interface with a processor via a coherence engine, referred to as a C-Box. Each C-Box provides dedicated facility of MSR to select uncore performance monitoring events and each C-Box event select MSR is paired with a counter register, similar in style as those described in Section 18.6.2.2. The layout of the event select MSRs in the C-Boxes are shown in Figure 18-31.

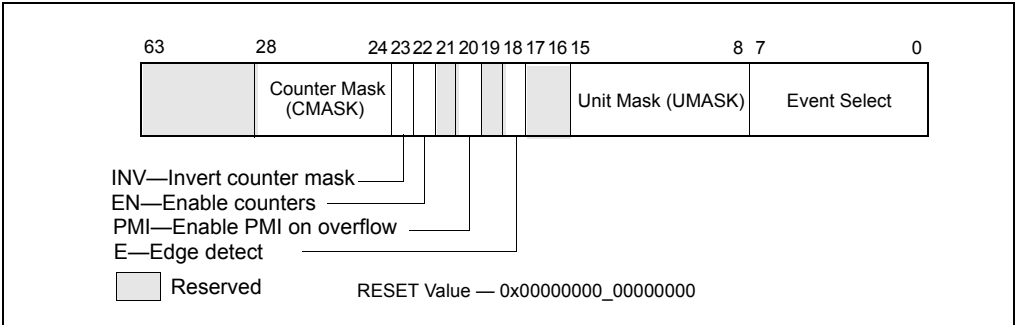


Figure 18-31. Layout of MSR\_UNC\_CBO\_N\_PERFEVTSELx MSR for C-Box N

At the uncore domain level, there is a master set of control MSRs that centrally manages all the performance monitoring facility of uncore units. Figure 18-32 shows the layout of the uncore domain global control

MSR bit 31 of MSR\_UNC\_PERF\_GLOBAL\_CTRL provides the capability to freeze all uncore counters when an overflow condition in a unit counter. When set and upon a counter overflow, the uncore PMU logic will clear the global enable bit, bit 29.

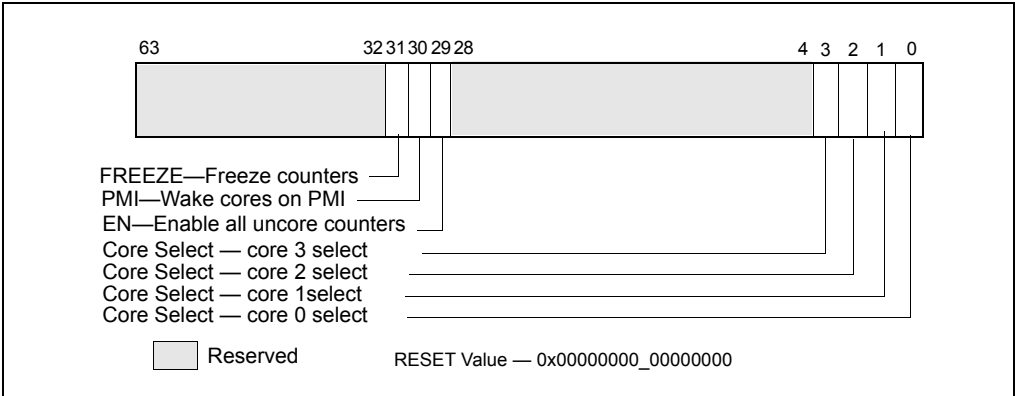


Figure 18-32. Layout of MSR\_UNC\_PERF\_GLOBAL\_CTRL MSR for Uncore

Additionally, there is also a fixed counter, counting uncore clockticks, for the uncore domain. Table 18-28 summarizes the number MSRs for uncore PMU for each box.

**Table 18-28. Uncore PMU MSR Summary**

Box	# of Boxes	Counters per Box	Counter Width	General Purpose	Global Enable	Comment
C-Box	Up to 4	2	44	Yes	Per-box	
NCU		1	48	No	Uncore	

### 18.8.6.1 Uncore Performance Monitoring Events

There are certain restrictions on the uncore performance counters in each C-Box. Specifically,

- Occupancy events are supported only with counter 0 but not counter 1.

Other uncore C-Box events can be programmed with either counter 0 or 1.

The C-Box uncore performance events described in Table 19-6 can collect performance characteristics of transactions initiated by processor core. In that respect, they are similar to various sub-events in the OFFCORE\_RESPONSE family of performance events in the core PMU. Information such as data supplier locality (LLC HIT/MISS) and snoop responses can be collected via OFFCORE\_RESPONSE and qualified on a per-thread basis.

On the other hand, uncore performance event logic can not associate its counts with the same level of per-thread qualification attributes as the core PMU events can. Therefore, whenever similar event programming capabilities are available from both core PMU and uncore PMU, the recommendation is that utilizing the core PMU events may be less affected by artifacts, complex interactions and other factors.

## 18.8.7 Intel® Xeon® Processor E5 Family Performance Monitoring Facility

The Intel® Xeon® Processor E5 Family (and Intel® Core™ i7-3930K Processor) are based on Intel microarchitecture code name Sandy Bridge. While the processor cores share the same microarchitecture as those of the Intel® Xeon® Processor E3 Family and second generation Intel Core i7-2xxx, Intel Core i5-2xxx, Intel Core i3-2xxx processor series, the uncore subsystems are different. An overview of the uncore performance monitoring facilities of the Intel Xeon processor E5 family (and Intel Core i7-3930K processor) is described in Section 18.8.8.

Thus, the performance monitoring facilities in the processor core generally are the same as those described in Section 18.8 through Section 18.8.5. However, the MSR\_OFFCORE\_RSP\_0/MSR\_OFFCORE\_RSP\_1 Response Supplier Info field shown in Table 18-26 applies to Intel Core Processors with CPUID signature of DisplayFamily\_DisplayModel encoding of 06\_2AH; next generation Intel Xeon processor with CPUID signature of DisplayFamily\_DisplayModel encoding of 06\_2DH supports an additional field for remote DRAM controller shown in Table 18-29. Addi-



tionally, there are some small differences in the non-architectural performance monitoring events (see Table 19-4).

**Table 18-29. MSR\_OFFCORE\_RSP\_x Supplier Info Field Definition for Next Generation Intel Xeon Processor**

Subtype	Bit Name	Offset	Description
Common	Any	16	(R/W). Catch all value for any response types.
Supplier Info	NO_SUPP	17	(R/W). No Supplier Information available
	LLC_HITM	18	(R/W). M-state initial lookup stat in L3.
	LLC_HITE	19	(R/W). E-state
	LLC_HITS	20	(R/W). S-state
	LLC_HITF	21	(R/W). F-state
	LOCAL	22	(R/W). Local DRAM Controller
	Remote	30:23	(R/W); Remote DRAM Controller (either all 0s or all 1s)

### 18.8.8 Intel® Xeon® Processor E5 Family Uncore Performance Monitoring Facility

The uncore subsystem in the Intel Xeon processor E5 family based on Intel microarchitecture Sandy Bridge has some similarities with those of the Intel Xeon processor E7 family based on Intel microarchitecture Sandy Bridge. Within the uncore subsystem, localized performance counter sets are provided at logic control unit scope. For example, each Cbox caching agent has a set of local performance counters, and the power controller unit (PCU) has its own local performance counters. Up to 8 C-Box units are supported in the uncore sub-system.

Table 18-30 summarizes the uncore PMU facilities providing MSR interfaces.

**Table 18-30. Uncore PMU MSR Summary for Intel® Xeon® Processor E5 Family**

Box	# of Boxes	Counters per Box	Counter Width	General Purpose	Global Enable	Sub-control MSRs
C-Box	8	4	44	Yes	per-box	None
PCU	1	4	48	Yes	per-box	Match/Mask
U-Box	1	2	44	Yes	uncore	None

## 18.9 NEXT GENERATION INTEL CORE PROCESSOR PERFORMANCE MONITORING FACILITY

The Next Generation Intel Core processor is based on Intel® microarchitecture code name Ivy Bridge. The performance monitoring facilities in the processor core generally are the same as those described in Section 18.8 through Section 18.8.5. The non-architectural performance monitoring events supported by the processor core are listed in Table 19-4.

## 18.10 PERFORMANCE MONITORING (PROCESSORS BASED ON INTEL NETBURST® MICROARCHITECTURE)

The performance monitoring mechanism provided in Pentium 4 and Intel Xeon processors is different from that provided in the P6 family and Pentium processors. While the general concept of selecting, filtering, counting, and reading performance events through the WRMSR, RDMSR, and RDPMC instructions is unchanged, the setup mechanism and MSR layouts are incompatible with the P6 family and Pentium processor mechanisms. Also, the RDPMC instruction has been enhanced to read the the additional performance counters provided in the Pentium 4 and Intel Xeon processors and to allow faster reading of counters.

The event monitoring mechanism provided with the Pentium 4 and Intel Xeon processors (based on Intel NetBurst microarchitecture) consists of the following facilities:

- The IA32\_MISC\_ENABLE MSR, which indicates the availability in an Intel 64 or IA-32 processor of the performance monitoring and precise event-based sampling (PEBS) facilities.
- Event selection control (ESCR) MSRs for selecting events to be monitored with specific performance counters. The number available differs by family and model (43 to 45).
- 18 performance counter MSRs for counting events.
- 18 counter configuration control (CCCR) MSRs, with one CCCR associated with each performance counter. CCCRs sets up an associated performance counter for a specific method of counting.
- A debug store (DS) save area in memory for storing PEBS records.
- The IA32\_DS\_AREA MSR, which establishes the location of the DS save area.
- The debug store (DS) feature flag (bit 21) returned by the CPUID instruction, which indicates the availability of the DS mechanism.
- The MSR\_PEBS\_ENABLE MSR, which enables the PEBS facilities and replay tagging used in at-retirement event counting.

PERFORMANCE MONITORING

- A set of predefined events and event metrics that simplify the setting up of the performance counters to count specific events.

Table 18-31 lists the performance counters and their associated CCCRs, along with the ESCRs that select events to be counted for each performance counter. Predefined event metrics and events are listed in Chapter 19, "Performance-Monitoring Events."

**Table 18-31. Performance Counter MSRs and Associated CCCR and ESCR MSRs (Pentium 4 and Intel Xeon Processors)**

Counter			CCCR		ESCR		
Name	No.	Addr	Name	Addr	Name	No.	Addr
MSR_BPU_COUNTER0	0	300H	MSR_BPU_CCCR0	360H	MSR_BSU_ESCRO MSR_FSB_ESCRO MSR_MOB_ESCRO MSR_PMH_ESCRO MSR_BPU_ESCRO MSR_IS_ESCRO MSR_ITLB_ESCRO MSR_IX_ESCRO	7 6 2 4 0 1 3 5	3A0H 3A2H 3AAH 3ACH 3B2H 3B4H 3B6H 3C8H
MSR_BPU_COUNTER1	1	301H	MSR_BPU_CCCR1	361H	MSR_BSU_ESCRO MSR_FSB_ESCRO MSR_MOB_ESCRO MSR_PMH_ESCRO MSR_BPU_ESCRO MSR_IS_ESCRO MSR_ITLB_ESCRO MSR_IX_ESCRO	7 6 2 4 0 1 3 5	3A0H 3A2H 3AAH 3ACH 3B2H 3B4H 3B6H 3C8H
MSR_BPU_COUNTER2	2	302H	MSR_BPU_CCCR2	362H	MSR_BSU_ESCR1 MSR_FSB_ESCR1 MSR_MOB_ESCR1 MSR_PMH_ESCR1 MSR_BPU_ESCR1 MSR_IS_ESCR1 MSR_ITLB_ESCR1 MSR_IX_ESCR1	7 6 2 4 0 1 3 5	3A1H 3A3H 3ABH 3ADH 3B3H 3B5H 3B7H 3C9H
MSR_BPU_COUNTER3	3	303H	MSR_BPU_CCCR3	363H	MSR_BSU_ESCR1 MSR_FSB_ESCR1 MSR_MOB_ESCR1 MSR_PMH_ESCR1 MSR_BPU_ESCR1 MSR_IS_ESCR1 MSR_ITLB_ESCR1 MSR_IX_ESCR1	7 6 2 4 0 1 3 5	3A1H 3A3H 3ABH 3ADH 3B3H 3B5H 3B7H 3C9H
MSR_MS_COUNTER0	4	304H	MSR_MS_CCCR0	364H	MSR_MS_ESCRO MSR_TBPU_ESCRO MSR_TC_ESCRO	0 2 1	3C0H 3C2H 3C4H
MSR_MS_COUNTER1	5	305H	MSR_MS_CCCR1	365H	MSR_MS_ESCRO MSR_TBPU_ESCRO MSR_TC_ESCRO	0 2 1	3C0H 3C2H 3C4H

**Table 18-31. Performance Counter MSRs and Associated CCCR and ESCR MSRs (Pentium 4 and Intel Xeon Processors) (Contd.)**

Counter			CCCR		ESCR		
Name	No.	Addr	Name	Addr	Name	No.	Addr
MSR_MS_COUNTER2	6	306H	MSR_MS_CCCR2	366H	MSR_MS_ESCR1 MSR_TBPU_ESCR1 MSR_TC_ESCR1	0 2 1	3C1H 3C3H 3C5H
MSR_MS_COUNTER3	7	307H	MSR_MS_CCCR3	367H	MSR_MS_ESCR1 MSR_TBPU_ESCR1 MSR_TC_ESCR1	0 2 1	3C1H 3C3H 3C5H
MSR_FLAME_COUNTER0	8	308H	MSR_FLAME_CCCR0	368H	MSR_FIRM_ESCR0 MSR_FLAME_ESCR0 MSR_DAC_ESCR0 MSR_SAAT_ESCR0 MSR_U2L_ESCR0	1 0 5 2 3	3A4H 3A6H 3A8H 3AEH 3B0H
MSR_FLAME_COUNTER1	9	309H	MSR_FLAME_CCCR1	369H	MSR_FIRM_ESCR0 MSR_FLAME_ESCR0 MSR_DAC_ESCR0 MSR_SAAT_ESCR0 MSR_U2L_ESCR0	1 0 5 2 3	3A4H 3A6H 3A8H 3AEH 3B0H
MSR_FLAME_COUNTER2	10	30AH	MSR_FLAME_CCCR2	36AH	MSR_FIRM_ESCR1 MSR_FLAME_ESCR1 MSR_DAC_ESCR1 MSR_SAAT_ESCR1 MSR_U2L_ESCR1	1 0 5 2 3	3A5H 3A7H 3A9H 3AFH 3B1H
MSR_FLAME_COUNTER3	11	30BH	MSR_FLAME_CCCR3	36BH	MSR_FIRM_ESCR1 MSR_FLAME_ESCR1 MSR_DAC_ESCR1 MSR_SAAT_ESCR1 MSR_U2L_ESCR1	1 0 5 2 3	3A5H 3A7H 3A9H 3AFH 3B1H
MSR_IQ_COUNTER0	12	30CH	MSR_IQ_CCCR0	36CH	MSR_CRU_ESCR0 MSR_CRU_ESCR2 MSR_CRU_ESCR4 MSR_IQ_ESCR0 <sup>1</sup> MSR_RAT_ESCR0 MSR_SSU_ESCR0 MSR_ALF_ESCR0	4 5 6 0 2 3 1	3B8H 3CCH 3E0H 3BAH 3BCH 3BEH 3CAH
MSR_IQ_COUNTER1	13	30DH	MSR_IQ_CCCR1	36DH	MSR_CRU_ESCR0 MSR_CRU_ESCR2 MSR_CRU_ESCR4 MSR_IQ_ESCR0 <sup>1</sup> MSR_RAT_ESCR0 MSR_SSU_ESCR0 MSR_ALF_ESCR0	4 5 6 0 2 3 1	3B8H 3CCH 3E0H 3BAH 3BCH 3BEH 3CAH
MSR_IQ_COUNTER2	14	30EH	MSR_IQ_CCCR2	36EH	MSR_CRU_ESCR1 MSR_CRU_ESCR3 MSR_CRU_ESCR5 MSR_IQ_ESCR1 <sup>1</sup> MSR_RAT_ESCR1 MSR_ALF_ESCR1	4 5 6 0 2 1	3B9H 3CDH 3E1H 3BBH 3BDH 3CBH

**Table 18-31. Performance Counter MSRs and Associated CCCR and ESCR MSRs (Pentium 4 and Intel Xeon Processors) (Contd.)**

Counter			CCCR		ESCR		
Name	No.	Addr	Name	Addr	Name	No.	Addr
MSR_IQ_COUNTER3	15	30FH	MSR_IQ_CCCR3	36FH	MSR_CRU_ESCR1	4	3B9H
					MSR_CRU_ESCR3	5	3CDH
					MSR_CRU_ESCR5	6	3E1H
					MSR_IQ_ESCR1 <sup>1</sup>	0	3BBH
					MSR_RAT_ESCR1	2	3BDH
					MSR_ALF_ESCR1	1	3CBH
MSR_IQ_COUNTER4	16	310H	MSR_IQ_CCCR4	370H	MSR_CRU_ESCR0	4	3B8H
					MSR_CRU_ESCR2	5	3CCH
					MSR_CRU_ESCR4	6	3E0H
					MSR_IQ_ESCR0 <sup>1</sup>	0	3BAH
					MSR_RAT_ESCR0	2	3BCH
					MSR_SSU_ESCR0	3	3BEH
					MSR_ALF_ESCR0	1	3CAH
MSR_IQ_COUNTER5	17	311H	MSR_IQ_CCCR5	371H	MSR_CRU_ESCR1	4	3B9H
					MSR_CRU_ESCR3	5	3CDH
					MSR_CRU_ESCR5	6	3E1H
					MSR_IQ_ESCR1 <sup>1</sup>	0	3BBH
					MSR_RAT_ESCR1	2	3BDH
					MSR_ALF_ESCR1	1	3CBH

**NOTES:**

1. MSR\_IQ\_ESCR0 and MSR\_IQ\_ESCR1 are available only on early processor builds (family 0FH, models 01H-02H). These MSRs are not available on later versions.

The types of events that can be counted with these performance monitoring facilities are divided into two classes: non-retirement events and at-retirement events.

- Non-retirement events (see Table 19-16) are events that occur any time during instruction execution (such as bus transactions or cache transactions).
- At-retirement events (see Table 19-17) are events that are counted at the retirement stage of instruction execution, which allows finer granularity in counting events and capturing machine state.

The at-retirement counting mechanism includes facilities for tagging  $\mu$ ops that have encountered a particular performance event during instruction execution. Tagging allows events to be sorted between those that occurred on an execution path that resulted in architectural state being committed at retirement as well as events that occurred on an execution path where the results were eventually cancelled and never committed to architectural state (such as, the execution of a mispredicted branch).

The Pentium 4 and Intel Xeon processor performance monitoring facilities support the three usage models described below. The first two models can be used to count both non-retirement and at-retirement events; the third model is used to count a subset of at-retirement events:

- **Event counting** — A performance counter is configured to count one or more types of events. While the counter is counting, software reads the counter at

selected intervals to determine the number of events that have been counted between the intervals.

- **Non-precise event-based sampling** — A performance counter is configured to count one or more types of events and to generate an interrupt when it overflows. To trigger an overflow, the counter is preset to a modulus value that will cause the counter to overflow after a specific number of events have been counted.

When the counter overflows, the processor generates a performance monitoring interrupt (PMI). The interrupt service routine for the PMI then records the return instruction pointer (RIP), resets the modulus, and restarts the counter. Code performance can be analyzed by examining the distribution of RIPs with a tool like the VTune™ Performance Analyzer.

- **Precise event-based sampling (PEBS)** — This type of performance monitoring is similar to non-precise event-based sampling, except that a memory buffer is used to save a record of the architectural state of the processor whenever the counter overflows. The records of architectural state provide additional information for use in performance tuning. Precise event-based sampling can be used to count only a subset of at-retirement events.

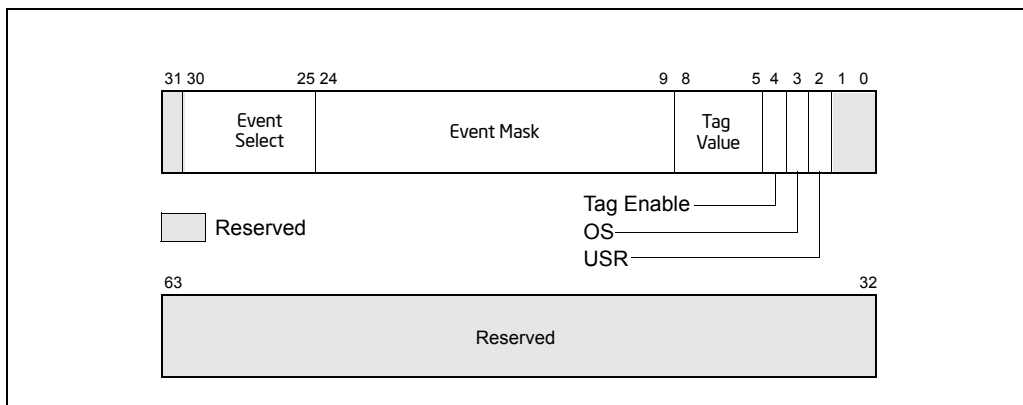
The following sections describe the MSR and data structures used for performance monitoring in the Pentium 4 and Intel Xeon processors.

### 18.10.1 ESCR MSRs

The 45 ESCR MSRs (see Table 18-31) allow software to select specific events to be countered. Each ESCR is usually associated with a pair of performance counters (see Table 18-31) and each performance counter has several ESCRs associated with it (allowing the events counted to be selected from a variety of events).

Figure 18-33 shows the layout of an ESCR MSR. The functions of the flags and fields are:

- **USR flag, bit 2** — When set, events are counted when the processor is operating at a current privilege level (CPL) of 1, 2, or 3. These privilege levels are generally used by application code and unprotected operating system code.
- **OS flag, bit 3** — When set, events are counted when the processor is operating at CPL of 0. This privilege level is generally reserved for protected operating system code. (When both the OS and USR flags are set, events are counted at all privilege levels.)



**Figure 18-33. Event Selection Control Register (ESCR) for Pentium 4 and Intel Xeon Processors without Intel HT Technology Support**

- **Tag enable, bit 4** — When set, enables tagging of  $\mu$ ops to assist in at-retirement event counting; when clear, disables tagging. See Section 18.10.6, “At-Retirement Counting.”
- **Tag value field, bits 5 through 8** — Selects a tag value to associate with a  $\mu$ op to assist in at-retirement event counting.
- **Event mask field, bits 9 through 24** — Selects events to be counted from the event class selected with the event select field.
- **Event select field, bits 25 through 30)** — Selects a class of events to be counted. The events within this class that are counted are selected with the event mask field.

When setting up an ESCR, the event select field is used to select a specific class of events to count, such as retired branches. The event mask field is then used to select one or more of the specific events within the class to be counted. For example, when counting retired branches, four different events can be counted: branch not taken predicted, branch not taken mispredicted, branch taken predicted, and branch taken mispredicted. The OS and USR flags allow counts to be enabled for events that occur when operating system code and/or application code are being executed. If neither the OS nor USR flag is set, no events will be counted.

The ESCRs are initialized to all 0s on reset. The flags and fields of an ESCR are configured by writing to the ESCR using the WRMSR instruction. Table 18-31 gives the addresses of the ESCR MSRs.

Writing to an ESCR MSR does not enable counting with its associated performance counter; it only selects the event or events to be counted. The CCCR for the selected performance counter must also be configured. Configuration of the CCCR includes selecting the ESCR and enabling the counter.

## 18.10.2 Performance Counters

The performance counters in conjunction with the counter configuration control registers (CCCRs) are used for filtering and counting the events selected by the ESCRs. The Pentium 4 and Intel Xeon processors provide 18 performance counters organized into 9 pairs. A pair of performance counters is associated with a particular subset of events and ESCR's (see Table 18-31). The counter pairs are partitioned into four groups:

- The BPU group, includes two performance counter pairs:
  - MSR\_BPU\_COUNTER0 and MSR\_BPU\_COUNTER1.
  - MSR\_BPU\_COUNTER2 and MSR\_BPU\_COUNTER3.
- The MS group, includes two performance counter pairs:
  - MSR\_MS\_COUNTER0 and MSR\_MS\_COUNTER1.
  - MSR\_MS\_COUNTER2 and MSR\_MS\_COUNTER3.
- The FLAME group, includes two performance counter pairs:
  - MSR\_FLAME\_COUNTER0 and MSR\_FLAME\_COUNTER1.
  - MSR\_FLAME\_COUNTER2 and MSR\_FLAME\_COUNTER3.
- The IQ group, includes three performance counter pairs:
  - MSR\_IQ\_COUNTER0 and MSR\_IQ\_COUNTER1.
  - MSR\_IQ\_COUNTER2 and MSR\_IQ\_COUNTER3.
  - MSR\_IQ\_COUNTER4 and MSR\_IQ\_COUNTER5.

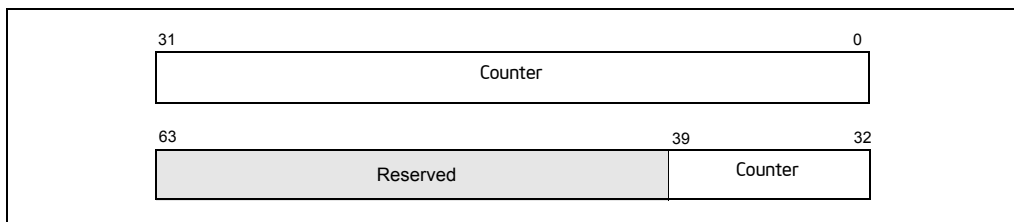
The MSR\_IQ\_COUNTER4 counter in the IQ group provides support for the PEBS.

Alternate counters in each group can be cascaded: the first counter in one pair can start the first counter in the second pair and vice versa. A similar cascading is possible for the second counters in each pair. For example, within the BPU group of counters, MSR\_BPU\_COUNTER0 can start MSR\_BPU\_COUNTER2 and vice versa, and MSR\_BPU\_COUNTER1 can start MSR\_BPU\_COUNTER3 and vice versa (see Section 18.10.5.6, "Cascading Counters"). The cascade flag in the CCCR register for the performance counter enables the cascading of counters.

Each performance counter is 40-bits wide (see Figure 18-34). The RDPMC instruction has been enhanced in the Pentium 4 and Intel Xeon processors to allow reading of either the full counter-width (40-bits) or the low 32-bits of the counter. Reading the low 32-bits is faster than reading the full counter width and is appropriate in situations where the count is small enough to be contained in 32 bits.

The RDPMC instruction can be used by programs or procedures running at any privilege level and in virtual-8086 mode to read these counters. The PCE flag in control register CR4 (bit 8) allows the use of this instruction to be restricted to only programs and procedures running at privilege level 0.





**Figure 18-34. Performance Counter (Pentium 4 and Intel Xeon Processors)**

The RDPMC instruction is not serializing or ordered with other instructions. Thus, it does not necessarily wait until all previous instructions have been executed before reading the counter. Similarly, subsequent instructions may begin execution before the RDPMC instruction operation is performed.

Only the operating system, executing at privilege level 0, can directly manipulate the performance counters, using the RDMSR and WRMSR instructions. A secure operating system would clear the PCE flag during system initialization to disable direct user access to the performance-monitoring counters, but provide a user-accessible programming interface that emulates the RDPMC instruction.

Some uses of the performance counters require the counters to be preset before counting begins (that is, before the counter is enabled). This can be accomplished by writing to the counter using the WRMSR instruction. To set a counter to a specified number of counts before overflow, enter a 2s complement negative integer in the counter. The counter will then count from the preset value up to -1 and overflow. Writing to a performance counter in a Pentium 4 or Intel Xeon processor with the WRMSR instruction causes all 40 bits of the counter to be written.

### 18.10.3 CCCR MSRs

Each of the 18 performance counters in a Pentium 4 or Intel Xeon processor has one CCCR MSR associated with it (see Table 18-31). The CCCRs control the filtering and counting of events as well as interrupt generation. Figure 18-35 shows the layout of an CCCR MSR. The functions of the flags and fields are as follows:

- **Enable flag, bit 12** — When set, enables counting; when clear, the counter is disabled. This flag is cleared on reset.
- **ESCR select field, bits 13 through 15** — Identifies the ESCR to be used to select events to be counted with the counter associated with the CCCR.
- **Compare flag, bit 18** — When set, enables filtering of the event count; when clear, disables filtering. The filtering method is selected with the threshold, complement, and edge flags.
- **Complement flag, bit 19** — Selects how the incoming event count is compared with the threshold value. When set, event counts that are less than or equal to the threshold value result in a single count being delivered to the performance

counter; when clear, counts greater than the threshold value result in a count being delivered to the performance counter (see Section 18.10.5.2, “Filtering Events”). The complement flag is not active unless the compare flag is set.

- **Threshold field, bits 20 through 23** — Selects the threshold value to be used for comparisons. The processor examines this field only when the compare flag is set, and uses the complement flag setting to determine the type of threshold comparison to be made. The useful range of values that can be entered in this field depend on the type of event being counted (see Section 18.10.5.2, “Filtering Events”).
- **Edge flag, bit 24** — When set, enables rising edge (false-to-true) edge detection of the threshold comparison output for filtering event counts; when clear, rising edge detection is disabled. This flag is active only when the compare flag is set.

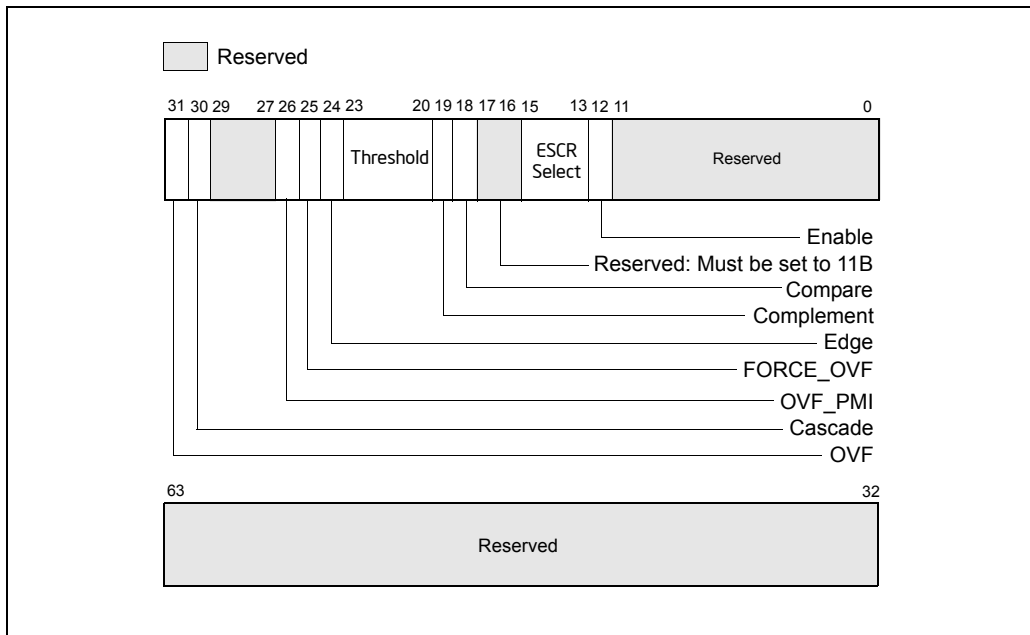


Figure 18-35. Counter Configuration Control Register (CCCR)

- **FORCE\_OVF flag, bit 25** — When set, forces a counter overflow on every counter increment; when clear, overflow only occurs when the counter actually overflows.
- **OVF\_PMI flag, bit 26** — When set, causes a performance monitor interrupt (PMI) to be generated when the counter overflows occurs; when clear, disables PMI generation. Note that the PMI is generated on the next event count after the counter has overflowed.

- **Cascade flag, bit 30** — When set, enables counting on one counter of a counter pair when its alternate counter in the other the counter pair in the same counter group overflows (see Section 18.10.2, “Performance Counters,” for further details); when clear, disables cascading of counters.
- **OVF flag, bit 31** — Indicates that the counter has overflowed when set. This flag is a sticky flag that must be explicitly cleared by software.

The CCCRs are initialized to all 0s on reset.

The events that an enabled performance counter actually counts are selected and filtered by the following flags and fields in the ESCR and CCCR registers and in the qualification order given:

1. The event select and event mask fields in the ESCR select a class of events to be counted and one or more event types within the class, respectively.
2. The OS and USR flags in the ESCR selected the privilege levels at which events will be counted.
3. The ESCR select field of the CCCR selects the ESCR. Since each counter has several ESCRs associated with it, one ESCR must be chosen to select the classes of events that may be counted.
4. The compare and complement flags and the threshold field of the CCCR select an optional threshold to be used in qualifying an event count.
5. The edge flag in the CCCR allows events to be counted only on rising-edge transitions.

The qualification order in the above list implies that the filtered output of one “stage” forms the input for the next. For instance, events filtered using the privilege level flags can be further qualified by the compare and complement flags and the threshold field, and an event that matched the threshold criteria, can be further qualified by edge detection.

The uses of the flags and fields in the CCCRs are discussed in greater detail in Section 18.10.5, “Programming the Performance Counters for Non-Retirement Events.”

### 18.10.4 Debug Store (DS) Mechanism

The debug store (DS) mechanism was introduced in the Pentium 4 and Intel Xeon processors to allow various types of information to be collected in memory-resident buffers for use in debugging and tuning programs. For the Pentium 4 and Intel Xeon processors, the DS mechanism is used to collect two types of information: branch records and precise event-based sampling (PEBS) records. The availability of the DS mechanism in a processor is indicated with the DS feature flag (bit 21) returned by the CPUID instruction.

See Section 17.4.5, “Branch Trace Store (BTS),” and Section 18.10.7, “Precise Event-Based Sampling (PEBS),” for a description of these facilities. Records collected with the DS mechanism are saved in the DS save area. See Section 17.4.9, “BTS and DS Save Area.”

## 18.10.5 Programming the Performance Counters for Non-Retirement Events

The basic steps to program a performance counter and to count events include the following:

1. Select the event or events to be counted.
2. For each event, select an ESCR that supports the event using the values in the ESCR restrictions row in Table 19-16, Chapter 19.
3. Match the CCCR Select value and ESCR name in Table 19-16 to a value listed in Table 18-31; select a CCCR and performance counter.
4. Set up an ESCR for the specific event or events to be counted and the privilege levels at which they are to be counted.
5. Set up the CCCR for the performance counter by selecting the ESCR and the desired event filters.
6. Set up the CCCR for optional cascading of event counts, so that when the selected counter overflows its alternate counter starts.
7. Set up the CCCR to generate an optional performance monitor interrupt (PMI) when the counter overflows. If PMI generation is enabled, the local APIC must be set up to deliver the interrupt to the processor and a handler for the interrupt must be in place.
8. Enable the counter to begin counting.

### 18.10.5.1 Selecting Events to Count

Table 19-17 in Chapter 19 lists a set of at-retirement events for the Pentium 4 and Intel Xeon processors. For each event listed in Table 19-17, setup information is provided. Table 18-32 gives an example of one of the events.

**Table 18-32. Event Example**

Event Name	Event Parameters	Parameter Value	Description
branch_retired			Counts the retirement of a branch. Specify one or more mask bits to select any combination of branch taken, not-taken, predicted and mispredicted.
	ESCR restrictions	MSR_CRU_ESCR2 MSR_CRU_ESCR3	See Table 15-3 for the addresses of the ESCR MSRs
	Counter numbers per ESCR	ESCR2: 12, 13, 16 ESCR3: 14, 15, 17	The counter numbers associated with each ESCR are provided. The performance counters and corresponding CCCRs can be obtained from Table 15-3.

Table 18-32. Event Example (Contd.)

Event Name	Event Parameters	Parameter Value	Description
	ESCR Event Select	06H	ESCR[31:25]
	ESCR Event Mask	Bit 0: MMNP 1: MMNM 2: MMTP 3: MMTM	ESCR[24:9], Branch Not-taken Predicted, Branch Not-taken Mispredicted, Branch Taken Predicted, Branch Taken Mispredicted.
	CCCR Select	05H	CCCR[15:13]
	Event Specific Notes		P6: EMON_BR_INST_RETIRED
	Can Support PEBS	No	
	Requires Additional MSRs for Tagging	No	

For Table 19-16 and Table 19-17, Chapter 19, the name of the event is listed in the Event Name column and parameters that define the event and other information are listed in the Event Parameters column. The Parameter Value and Description columns give specific parameters for the event and additional description information. Entries in the Event Parameters column are described below.

- **ESCR restrictions** — Lists the ESCRs that can be used to program the event. Typically only one ESCR is needed to count an event.
- **Counter numbers per ESCR** — Lists which performance counters are associated with each ESCR. Table 18-31 gives the name of the counter and CCCR for each counter number. Typically only one counter is needed to count the event.
- **ESCR event select** — Gives the value to be placed in the event select field of the ESCR to select the event.
- **ESCR event mask** — Gives the value to be placed in the Event Mask field of the ESCR to select sub-events to be counted. The parameter value column defines the documented bits with relative bit position offset starting from 0, where the absolute bit position of relative offset 0 is bit 9 of the ESCR. All undocumented bits are reserved and should be set to 0.
- **CCCR select** — Gives the value to be placed in the ESCR select field of the CCCR associated with the counter to select the ESCR to be used to define the event. This value is not the address of the ESCR; it is the number of the ESCR from the Number column in Table 18-31.
- **Event specific notes** — Gives additional information about the event, such as the name of the same or a similar event defined for the P6 family processors.
- **Can support PEBS** — Indicates if PEBS is supported for the event (only supplied for at-retirement events listed in Table 19-17.)

- **Requires additional MSR for tagging** — Indicates which if any additional MSRs must be programmed to count the events (only supplied for the at-retirement events listed in Table 19-17.)

### NOTE

The performance-monitoring events listed in Chapter 19, “Performance-Monitoring Events,” are intended to be used as guides for performance tuning. The counter values reported are not guaranteed to be absolutely accurate and should be used as a relative guide for tuning. Known discrepancies are documented where applicable.

The following procedure shows how to set up a performance counter for basic counting; that is, the counter is set up to count a specified event indefinitely, wrapping around whenever it reaches its maximum count. This procedure is continued through the following four sections.

Using information in Table 19-16, Chapter 19, an event to be counted can be selected as follows:

1. Select the event to be counted.
2. Select the ESCR to be used to select events to be counted from the ESCRs field.
3. Select the number of the counter to be used to count the event from the Counter Numbers Per ESCR field.
4. Determine the name of the counter and the CCCR associated with the counter, and determine the MSR addresses of the counter, CCCR, and ESCR from Table 18-31.
5. Use the WRMSR instruction to write the ESCR Event Select and ESCR Event Mask values into the appropriate fields in the ESCR. At the same time set or clear the USR and OS flags in the ESCR as desired.
6. Use the WRMSR instruction to write the CCCR Select value into the appropriate field in the CCCR.

### NOTE

Typically all the fields and flags of the CCCR will be written with one WRMSR instruction; however, in this procedure, several WRMSR writes are used to more clearly demonstrate the uses of the various CCCR fields and flags.

This setup procedure is continued in the next section, Section 18.10.5.2, “Filtering Events.”

## 18.10.5.2 Filtering Events

Each counter receives up to 4 input lines from the processor hardware from which it is counting events. The counter treats these inputs as binary inputs (input 0 has a

value of 1, input 1 has a value of 2, input 3 has a value of 4, and input 3 has a value of 8). When a counter is enabled, it adds this binary input value to the counter value on each clock cycle. For each clock cycle, the value added to the counter can then range from 0 (no event) to 15.

For many events, only the 0 input line is active, so the counter is merely counting the clock cycles during which the 0 input is asserted. However, for some events two or more input lines are used. Here, the counter's threshold setting can be used to filter events. The compare, complement, threshold, and edge fields control the filtering of counter increments by input value.

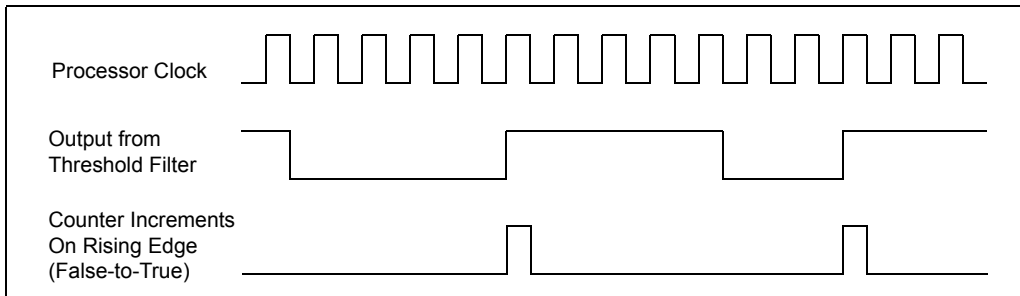
If the compare flag is set, then a "greater than" or a "less than or equal to" comparison of the input value vs. a threshold value can be made. The complement flag selects "less than or equal to" (flag set) or "greater than" (flag clear). The threshold field selects a threshold value of from 0 to 15. For example, if the complement flag is cleared and the threshold field is set to 6, then any input value of 7 or greater on the 4 inputs to the counter will cause the counter to be incremented by 1, and any value less than 7 will cause an increment of 0 (or no increment) of the counter. Conversely, if the complement flag is set, any value from 0 to 6 will increment the counter and any value from 7 to 15 will not increment the counter. Note that when a threshold condition has been satisfied, the input to the counter is always 1, not the input value that is presented to the threshold filter.

The edge flag provides further filtering of the counter inputs when a threshold comparison is being made. The edge flag is only active when the compare flag is set. When the edge flag is set, the resulting output from the threshold filter (a value of 0 or 1) is used as an input to the edge filter. Each clock cycle, the edge filter examines the last and current input values and sends a count to the counter only when it detects a "rising edge" event; that is, a false-to-true transition. Figure 18-36 illustrates rising edge filtering.

The following procedure shows how to configure a CCCR to filter events using the threshold filter and the edge filter. This procedure is a continuation of the setup procedure introduced in Section 18.10.5.1, "Selecting Events to Count."

7. (Optional) To set up the counter for threshold filtering, use the WRMSR instruction to write values in the CCCR compare and complement flags and the threshold field:
  - Set the compare flag.
  - Set or clear the complement flag for less than or equal to or greater than comparisons, respectively.
  - Enter a value from 0 to 15 in the threshold field.
8. (Optional) Select rising edge filtering by setting the CCCR edge flag.

This setup procedure is continued in the next section, Section 18.10.5.3, "Starting Event Counting."



**Figure 18-36. Effects of Edge Filtering**

### 18.10.5.3 Starting Event Counting

Event counting by a performance counter can be initiated in either of two ways. The typical way is to set the enable flag in the counter's CCCR. Following the instruction to set the enable flag, event counting begins and continues until it is stopped (see Section 18.10.5.5, "Halting Event Counting").

The following procedural step shows how to start event counting. This step is a continuation of the setup procedure introduced in Section 18.10.5.2, "Filtering Events."

9. To start event counting, use the WRMSR instruction to set the CCCR enable flag for the performance counter.

This setup procedure is continued in the next section, Section 18.10.5.4, "Reading a Performance Counter's Count."

The second way that a counter can be started is by using the cascade feature. Here, the overflow of one counter automatically starts its alternate counter (see Section 18.10.5.6, "Cascading Counters").

### 18.10.5.4 Reading a Performance Counter's Count

The Pentium 4 and Intel Xeon processors' performance counters can be read using either the RDPMC or RDMSR instructions. The enhanced functions of the RDPMC instruction (including fast read) are described in Section 18.10.2, "Performance Counters." These instructions can be used to read a performance counter while it is counting or when it is stopped.

The following procedural step shows how to read the event counter. This step is a continuation of the setup procedure introduced in Section 18.10.5.3, "Starting Event Counting."

10. To read a performance counter's current event count, execute the RDPMC instruction with the counter number obtained from Table 18-31 used as an operand.



This setup procedure is continued in the next section, Section 18.10.5.5, “Halting Event Counting.”

### 18.10.5.5 Halting Event Counting

After a performance counter has been started (enabled), it continues counting indefinitely. If the counter overflows (goes one count past its maximum count), it wraps around and continues counting. When the counter wraps around, it sets its OVF flag to indicate that the counter has overflowed. The OVF flag is a sticky flag that indicates that the counter has overflowed at least once since the OVF bit was last cleared.

To halt counting, the CCCR enable flag for the counter must be cleared.

The following procedural step shows how to stop event counting. This step is a continuation of the setup procedure introduced in Section 18.10.5.4, “Reading a Performance Counter’s Count.”

11. To stop event counting, execute a WRMSR instruction to clear the CCCR enable flag for the performance counter.

To halt a cascaded counter (a counter that was started when its alternate counter overflowed), either clear the Cascade flag in the cascaded counter’s CCCR MSR or clear the OVF flag in the alternate counter’s CCCR MSR.

### 18.10.5.6 Cascading Counters

As described in Section 18.10.2, “Performance Counters,” eighteen performance counters are implemented in pairs. Nine pairs of counters and associated CCRs are further organized as four blocks: BPU, MS, FLAME, and IQ (see Table 18-31). The first three blocks contain two pairs each. The IQ block contains three pairs of counters (12 through 17) with associated CCRs (MSR\_IQ\_CCCR0 through MSR\_IQ\_CCCR5).

The first 8 counter pairs (0 through 15) can be programmed using ESCRs to detect performance monitoring events. Pairs of ESCRs in each of the four blocks allow many different types of events to be counted. The cascade flag in the CCCR MSR allows nested monitoring of events to be performed by cascading one counter to a second counter located in another pair in the same block (see Figure 18-35 for the location of the flag).

Counters 0 and 1 form the first pair in the BPU block. Either counter 0 or 1 can be programmed to detect an event via MSR\_MO B\_ESCR0. Counters 0 and 2 can be cascaded in any order, as can counters 1 and 3. It’s possible to set up 4 counters in the same block to cascade on two pairs of independent events. The pairing described also applies to subsequent blocks. Since the IQ PUB has two extra counters, cascading operates somewhat differently if 16 and 17 are involved. In the IQ block, counter 16 can only be cascaded from counter 14 (not from 12); counter 14 cannot be cascaded from counter 16 using the CCCR cascade bit mechanism. Similar restrictions apply to counter 17.

### Example 18-1. Counting Events

Assume a scenario where counter X is set up to count 200 occurrences of event A; then counter Y is set up to count 400 occurrences of event B. Each counter is set up to count a specific event and overflow to the next counter. In the above example, counter X is preset for a count of -200 and counter Y for a count of -400; this setup causes the counters to overflow on the 200th and 400th counts respectively.

Continuing this scenario, counter X is set up to count indefinitely and wraparound on overflow. This is described in the basic performance counter setup procedure that begins in Section 18.10.5.1, "Selecting Events to Count." Counter Y is set up with the cascade flag in its associated CCCR MSR set to 1 and its enable flag set to 0.

To begin the nested counting, the enable bit for the counter X is set. Once enabled, counter X counts until it overflows. At this point, counter Y is automatically enabled and begins counting. Thus counter X overflows after 200 occurrences of event A. Counter Y then starts, counting 400 occurrences of event B before overflowing. When performance counters are cascaded, the counter Y would typically be set up to generate an interrupt on overflow. This is described in Section 18.10.5.8, "Generating an Interrupt on Overflow."

The cascading counters mechanism can be used to count a single event. The counting begins on one counter then continues on the second counter after the first counter overflows. This technique doubles the number of event counts that can be recorded, since the contents of the two counters can be added together.

### 18.10.5.7 EXTENDED CASCADING

Extended cascading is a model-specific feature in the Intel NetBurst microarchitecture. The feature is available to Pentium 4 and Xeon processor family with family encoding of 15 and model encoding greater than or equal to 2. This feature uses bit 11 in CCCRs associated with the IQ block. See Table 18-33.

**Table 18-33. CCR Names and Bit Positions**

CCCR Name:Bit Position	Bit Name	Description
MSR_IQ_CCCR1 2:11	Reserved	
MSR_IQ_CCCR0:11	CASCNT4INT00	Allow counter 4 to cascade into counter 0
MSR_IQ_CCCR3:11	CASCNT5INT03	Allow counter 5 to cascade into counter 3
MSR_IQ_CCCR4:11	CASCNT5INT04	Allow counter 5 to cascade into counter 4
MSR_IQ_CCCR5:11	CASCNT4INT05	Allow counter 4 to cascade into counter 5

## PERFORMANCE MONITORING

The extended cascading feature can be adapted to the sampling usage model for performance monitoring. However, it is known that performance counters do not generate PMI in cascade mode or extended cascade mode due to an erratum. This erratum applies to Pentium 4 and Intel Xeon processors with model encoding of 2. For Pentium 4 and Intel Xeon processors with model encoding of 0 and 1, the erratum applies to processors with stepping encoding greater than 09H.

Counters 16 and 17 in the IQ block are frequently used in precise event-based sampling or at-retirement counting of events indicating a stalled condition in the pipeline. Neither counter 16 or 17 can initiate the cascading of counter pairs using the cascade bit in a CCCR.

Extended cascading permits performance monitoring tools to use counters 16 and 17 to initiate cascading of two counters in the IQ block. Extended cascading from counter 16 and 17 is conceptually similar to cascading other counters, but instead of using CASCADE bit of a CCCR, one of the four CASCNTxINTOy bits is used.

### Example 18-2. Scenario for Extended Cascading

A usage scenario for extended cascading is to sample instructions retired on logical processor 1 after the first 4096 instructions retired on logical processor 0. A procedure to program extended cascading in this scenario is outlined below:

1. Write the value 0 to counter 12.
2. Write the value 04000603H to MSR\_CRU\_ESCR0 (corresponding to selecting the NBOGNTAG and NBOGTAG event masks with qualification restricted to logical processor 1).
3. Write the value 04038800H to MSR\_IQ\_CCCR0. This enables CASCNT4INTO0 and OVF\_PMI. An ISR can sample on instruction addresses in this case (do not set ENABLE, or CASCADE).
4. Write the value FFFFF000H into counter 16.1.
5. Write the value 0400060CH to MSR\_CRU\_ESCR2 (corresponding to selecting the NBOGNTAG and NBOGTAG event masks with qualification restricted to logical processor 0).
6. Write the value 00039000H to MSR\_IQ\_CCCR4 (set ENABLE bit, but not OVF\_PMI).

Another use for cascading is to locate stalled execution in a multithreaded application. Assume MOB replays in thread B cause thread A to stall. Getting a sample of the stalled execution in this scenario could be accomplished by:

1. Set up counter B to count MOB replays on thread B.
2. Set up counter A to count resource stalls on thread A; set its force overflow bit and the appropriate CASCNTxINTOy bit.
3. Use the performance monitoring interrupt to capture the program execution data of the stalled thread.

### 18.10.5.8 Generating an Interrupt on Overflow

Any performance counter can be configured to generate a performance monitor interrupt (PMI) if the counter overflows. The PMI interrupt service routine can then collect information about the state of the processor or program when overflow occurred. This information can then be used with a tool like the Intel® VTune™ Performance Analyzer to analyze and tune program performance.

To enable an interrupt on counter overflow, the `OVR_PMI` flag in the counter's associated CCCR MSR must be set. When overflow occurs, a PMI is generated through the local APIC. (Here, the performance counter entry in the local vector table [LVT] is set up to deliver the interrupt generated by the PMI to the processor.)

The PMI service routine can use the `OVF` flag to determine which counter overflowed when multiple counters have been configured to generate PMIs. Also, note that these processors mask PMIs upon receiving an interrupt. Clear this condition before leaving the interrupt handler.

When generating interrupts on overflow, the performance counter being used should be preset to value that will cause an overflow after a specified number of events are counted plus 1. The simplest way to select the preset value is to write a negative number into the counter, as described in Section 18.10.5.6, "Cascading Counters." Here, however, if an interrupt is to be generated after 100 event counts, the counter should be preset to minus 100 plus 1 ( $-100 + 1$ ), or -99. The counter will then overflow after it counts 99 events and generate an interrupt on the next (100th) event counted. The difference of 1 for this count enables the interrupt to be generated immediately after the selected event count has been reached, instead of waiting for the overflow to be propagation through the counter.

Because of latency in the microarchitecture between the generation of events and the generation of interrupts on overflow, it is sometimes difficult to generate an interrupt close to an event that caused it. In these situations, the `FORCE_OVF` flag in the CCCR can be used to improve reporting. Setting this flag causes the counter to overflow on every counter increment, which in turn triggers an interrupt after every counter increment.

### 18.10.5.9 Counter Usage Guideline

There are some instances where the user must take care to configure counting logic properly, so that it is not powered down. To use any ESCR, even when it is being used just for tagging, (any) one of the counters that the particular ESCR (or its paired ESCR) can be connected to should be enabled. If this is not done, 0 counts may result. Likewise, to use any counter, there must be some event selected in a corresponding ESCR (other than `no_event`, which generally has a select value of 0).

## 18.10.6 At-Retirement Counting

At-retirement counting provides a means counting only events that represent work committed to architectural state and ignoring work that was performed speculatively and later discarded.

The Intel NetBurst microarchitecture used in the Pentium 4 and Intel Xeon processors performs many speculative activities in an attempt to increase effective processing speeds. One example of this speculative activity is branch prediction. The Pentium 4 and Intel Xeon processors typically predict the direction of branches and then decode and execute instructions down the predicted path in anticipation of the actual branch decision. When a branch misprediction occurs, the results of instructions that were decoded and executed down the mispredicted path are canceled. If a performance counter was set up to count all executed instructions, the count would include instructions whose results were canceled as well as those whose results committed to architectural state.

To provide finer granularity in event counting in these situations, the performance monitoring facilities provided in the Pentium 4 and Intel Xeon processors provide a mechanism for tagging events and then counting only those tagged events that represent committed results. This mechanism is called “at-retirement counting.”

Tables 19-17 through 19-21 list predefined at-retirement events and event metrics that can be used to for tagging events when using at retirement counting. The following terminology is used in describing at-retirement counting:

- **Bogus, non-bogus, retire** — In at-retirement event descriptions, the term “bogus” refers to instructions or  $\mu$ ops that must be canceled because they are on a path taken from a mispredicted branch. The terms “retired” and “non-bogus” refer to instructions or  $\mu$ ops along the path that results in committed architectural state changes as required by the program being executed. Thus instructions and  $\mu$ ops are either bogus or non-bogus, but not both. Several of the Pentium 4 and Intel Xeon processors’ performance monitoring events (such as, `Instruction_Retired` and `Uops_Retired` in Table 19-17) can count instructions or  $\mu$ ops that are retired based on the characterization of “bogus” versus non-bogus.
- **Tagging** — Tagging is a means of marking  $\mu$ ops that have encountered a particular performance event so they can be counted at retirement. During the course of execution, the same event can happen more than once per  $\mu$ op and a direct count of the event would not provide an indication of how many  $\mu$ ops encountered that event.

The tagging mechanisms allow a  $\mu$ op to be tagged once during its lifetime and thus counted once at retirement. The retired suffix is used for performance metrics that increment a count once per  $\mu$ op, rather than once per event. For example, a  $\mu$ op may encounter a cache miss more than once during its life time, but a “Miss Retired” metric (that counts the number of retired  $\mu$ ops that encountered a cache miss) will increment only once for that  $\mu$ op. A “Miss Retired” metric would be useful for characterizing the performance of the cache hierarchy for a particular instruction sequence. Details of various performance metrics and how these can be constructed using the Pentium 4 and Intel Xeon processors

performance events are provided in the *Intel Pentium 4 Processor Optimization Reference Manual* (see Section 1.4, “Related Literature”).

- **Replay** — To maximize performance for the common case, the Intel NetBurst microarchitecture aggressively schedules  $\mu$ ops for execution before all the conditions for correct execution are guaranteed to be satisfied. In the event that all of these conditions are not satisfied,  $\mu$ ops must be reissued. The mechanism that the Pentium 4 and Intel Xeon processors use for this reissuing of  $\mu$ ops is called replay. Some examples of replay causes are cache misses, dependence violations, and unforeseen resource constraints. In normal operation, some number of replays is common and unavoidable. An excessive number of replays is an indication of a performance problem.
- **Assist** — When the hardware needs the assistance of microcode to deal with some event, the machine takes an assist. One example of this is an underflow condition in the input operands of a floating-point operation. The hardware must internally modify the format of the operands in order to perform the computation. Assists clear the entire machine of  $\mu$ ops before they begin and are costly.

### 18.10.6.1 Using At-Retirement Counting

The Pentium 4 and Intel Xeon processors allow counting both events and  $\mu$ ops that encountered a specified event. For a subset of the at-retirement events listed in Table 19-17, a  $\mu$ op may be tagged when it encounters that event. The tagging mechanisms can be used in non-precise event-based sampling, and a subset of these mechanisms can be used in PEBS. There are four independent tagging mechanisms, and each mechanism uses a different event to count  $\mu$ ops tagged with that mechanism:

- **Front-end tagging** — This mechanism pertains to the tagging of  $\mu$ ops that encountered front-end events (for example, trace cache and instruction counts) and are counted with the `Front_end_event` event
- **Execution tagging** — This mechanism pertains to the tagging of  $\mu$ ops that encountered execution events (for example, instruction types) and are counted with the `Execution_Event` event.
- **Replay tagging** — This mechanism pertains to tagging of  $\mu$ ops whose retirement is replayed (for example, a cache miss) and are counted with the `Replay_event` event. Branch mispredictions are also tagged with this mechanism.
- **No tags** — This mechanism does not use tags. It uses the `Instr_retired` and the `Uops_retired` events.

Each tagging mechanism is independent from all others; that is, a  $\mu$ op that has been tagged using one mechanism will not be detected with another mechanism’s tagged- $\mu$ op detector. For example, if  $\mu$ ops are tagged using the front-end tagging mechanisms, the `Replay_event` will not count those as tagged  $\mu$ ops unless they are also tagged using the replay tagging mechanism. However, execution tags allow up to four different types of  $\mu$ ops to be counted at retirement through execution tagging.

The independence of tagging mechanisms does not hold when using PEBS. When using PEBS, only one tagging mechanism should be used at a time.

Certain kinds of  $\mu$ ops that cannot be tagged, including I/O, uncacheable and locked accesses, returns, and far transfers.

Table 19-17 lists the performance monitoring events that support at-retirement counting: specifically the `Front_end_event`, `Execution_event`, `Replay_event`, `Inst_retired` and `Uops_retired` events. The following sections describe the tagging mechanisms for using these events to tag  $\mu$ op and count tagged  $\mu$ ops.

### 18.10.6.2 Tagging Mechanism for `Front_end_event`

The `Front_end_event` counts  $\mu$ ops that have been tagged as encountering any of the following events:

- **$\mu$ op decode events** — Tagging  $\mu$ ops for  $\mu$ op decode events requires specifying bits in the ESCR associated with the performance-monitoring event, `Uop_type`.
- **Trace cache events** — Tagging  $\mu$ ops for trace cache events may require specifying certain bits in the `MSR_TC_PRECISE_EVENT` MSR (see Table 19-19).

Table 19-17 describes the `Front_end_event` and Table 19-19 describes metrics that are used to set up a `Front_end_event` count.

The MSRs specified in the Table 19-17 that are supported by the front-end tagging mechanism must be set and one or both of the `NBOGUS` and `BOGUS` bits in the `Front_end_event` event mask must be set to count events. None of the events currently supported requires the use of the `MSR_TC_PRECISE_EVENT` MSR.

### 18.10.6.3 Tagging Mechanism For `Execution_event`

Table 19-17 describes the `Execution_event` and Table 19-20 describes metrics that are used to set up an `Execution_event` count.

The execution tagging mechanism differs from other tagging mechanisms in how it causes tagging. One *upstream* ESCR is used to specify an event to detect and to specify a tag value (bits 5 through 8) to identify that event. A second *downstream* ESCR is used to detect  $\mu$ ops that have been tagged with that tag value identifier using `Execution_event` for the event selection.

The upstream ESCR that counts the event must have its tag enable flag (bit 4) set and must have an appropriate tag value mask entered in its tag value field. The 4-bit tag value mask specifies which of tag bits should be set for a particular  $\mu$ op. The value selected for the tag value should coincide with the event mask selected in the downstream ESCR. For example, if a tag value of 1 is set, then the event mask of `NBOGUS0` should be enabled, correspondingly in the downstream ESCR. The downstream ESCR detects and counts tagged  $\mu$ ops. The normal (not tag value) mask bits in the downstream ESCR specify which tag bits to count. If any one of the tag bits selected by the mask is set, the related counter is incremented by one. This mechanism is summarized in the Table 19-20 metrics that are supported by the execution tagging mechanism. The tag enable and tag value bits are irrelevant for the downstream ESCR used to select the `Execution_event`.

The four separate tag bits allow the user to simultaneously but distinctly count up to four execution events at retirement. (This applies for non-precise event-based sampling. There are additional restrictions for PEBS as noted in Section 18.10.7.3, "Setting Up the PEBS Buffer.") It is also possible to detect or count combinations of events by setting multiple tag value bits in the upstream ESCR or multiple mask bits in the downstream ESCR. For example, use a tag value of 3H in the upstream ESCR and use NBOGUS0/NBOGUS1 in the downstream ESCR event mask.

#### 18.10.6.4 Tagging Mechanism for Replay\_event

Table 19-17 describes the `Replay_event` and Table 19-21 describes metrics that are used to set up an `Replay_event` count.

The replay mechanism enables tagging of  $\mu$ ops for a subset of all replays before retirement. Use of the replay mechanism requires selecting the type of  $\mu$ op that may experience the replay in the `MSR_PEBS_MATRIX_VERT` MSR and selecting the type of event in the `MSR_PEBS_ENABLE` MSR. Replay tagging must also be enabled with the `UOP_Tag` flag (bit 24) in the `MSR_PEBS_ENABLE` MSR.

The Table 19-21 lists the metrics that support the replay tagging mechanism and the at-retirement events that use the replay tagging mechanism, and specifies how the appropriate MSRs need to be configured. The replay tags defined in Table A-5 also enable Precise Event-Based Sampling (PEBS, see Section 15.9.8). Each of these replay tags can also be used in normal sampling by not setting Bit 24 nor Bit 25 in `IA_32_PEBS_ENABLE_MSR`. Each of these metrics requires that the `Replay_Event` (see Table 19-17) be used to count the tagged  $\mu$ ops.

### 18.10.7 Precise Event-Based Sampling (PEBS)

The debug store (DS) mechanism in processors based on Intel NetBurst microarchitecture allow two types of information to be collected for use in debugging and tuning programs: PEBS records and BTS records. See Section 17.4.5, "Branch Trace Store (BTS)," for a description of the BTS mechanism.

PEBS permits the saving of precise architectural information associated with one or more performance events in the precise event records buffer, which is part of the DS save area (see Section 17.4.9, "BTS and DS Save Area"). To use this mechanism, a counter is configured to overflow after it has counted a preset number of events. After the counter overflows, the processor copies the current state of the general-purpose and EFLAGS registers and instruction pointer into a record in the precise event records buffer. The processor then resets the count in the performance counter and restarts the counter. When the precise event records buffer is nearly full, an interrupt is generated, allowing the precise event records to be saved. A circular buffer is not supported for precise event records.

PEBS is supported only for a subset of the at-retirement events: `Execution_event`, `Front_end_event`, and `Replay_event`. Also, PEBS can only be carried out using the one performance counter, the `MSR_IQ_COUNTER4` MSR.



In processors based on Intel Core microarchitecture, a similar PEBS mechanism is also supported using IA32\_PMC0 and IA32\_PERFVTSEL0 MSRs (See Section 18.4.4).

### 18.10.7.1 Detection of the Availability of the PEBS Facilities

The DS feature flag (bit 21) returned by the CPUID instruction indicates (when set) the availability of the DS mechanism in the processor, which supports the PEBS (and BTS) facilities. When this bit is set, the following PEBS facilities are available:

- The PEBS\_UNAVAILABLE flag in the IA32\_MISC\_ENABLE MSR indicates (when clear) the availability of the PEBS facilities, including the MSR\_PEBS\_ENABLE MSR.
- The enable PEBS flag (bit 24) in the MSR\_PEBS\_ENABLE MSR allows PEBS to be enabled (set) or disabled (clear).
- The IA32\_DS\_AREA MSR can be programmed to point to the DS save area.

### 18.10.7.2 Setting Up the DS Save Area

Section 17.4.9.2, “Setting Up the DS Save Area,” describes how to set up and enable the DS save area. This procedure is common for PEBS and BTS.

### 18.10.7.3 Setting Up the PEBS Buffer

Only the MSR\_IQ\_COUNTER4 performance counter can be used for PEBS. Use the following procedure to set up the processor and this counter for PEBS:

1. Set up the precise event buffering facilities. Place values in the precise event buffer base, precise event index, precise event absolute maximum, and precise event interrupt threshold, and precise event counter reset fields of the DS buffer management area (see Figure 17-5) to set up the precise event records buffer in memory.
2. Enable PEBS. Set the Enable PEBS flag (bit 24) in MSR\_PEBS\_ENABLE MSR.
3. Set up the MSR\_IQ\_COUNTER4 performance counter and its associated CCCR and one or more ESCRs for PEBS as described in Tables 19-17 through 19-21.

### 18.10.7.4 Writing a PEBS Interrupt Service Routine

The PEBS facilities share the same interrupt vector and interrupt service routine (called the DS ISR) with the non-precise event-based sampling and BTS facilities. To handle PEBS interrupts, PEBS handler code must be included in the DS ISR. See Section 17.4.9.5, “Writing the DS Interrupt Service Routine,” for guidelines for writing the DS ISR.

### 18.10.7.5 Other DS Mechanism Implications

The DS mechanism is not available in the SMM. It is disabled on transition to the SMM mode. Similarly the DS mechanism is disabled on the generation of a machine check exception and is cleared on processor RESET and INIT.

The DS mechanism is available in real address mode.

### 18.10.8 Operating System Implications

The DS mechanism can be used by the operating system as a debugging extension to facilitate failure analysis. When using this facility, a 25 to 30 times slowdown can be expected due to the effects of the trace store occurring on every taken branch.

Depending upon intended usage, the instruction pointers that are part of the branch records or the PEBS records need to have an association with the corresponding process. One solution requires the ability for the DS specific operating system module to be chained to the context switch. A separate buffer can then be maintained for each process of interest and the MSR pointing to the configuration area saved and setup appropriately on each context switch.

If the BTS facility has been enabled, then it must be disabled and state stored on transition of the system to a sleep state in which processor context is lost. The state must be restored on return from the sleep state.

It is required that an interrupt gate be used for the DS interrupt as opposed to a trap gate to prevent the generation of an endless interrupt loop.

Pages that contain buffers must have mappings to the same physical address for all processes/logical processors, such that any change to CR3 will not change DS addresses. If this requirement cannot be satisfied (that is, the feature is enabled on a per thread/process basis), then the operating system must ensure that the feature is enabled/disabled appropriately in the context switch code.

## 18.11 PERFORMANCE MONITORING AND INTEL HYPER-THREADING TECHNOLOGY IN PROCESSORS BASED ON INTEL NETBURST® MICROARCHITECTURE

The performance monitoring capability of processors based on Intel NetBurst microarchitecture and supporting Intel Hyper-Threading Technology is similar to that described in Section 18.10. However, the capability is extended so that:

- Performance counters can be programmed to select events qualified by logical processor IDs.
- Performance monitoring interrupts can be directed to a specific logical processor within the physical processor.

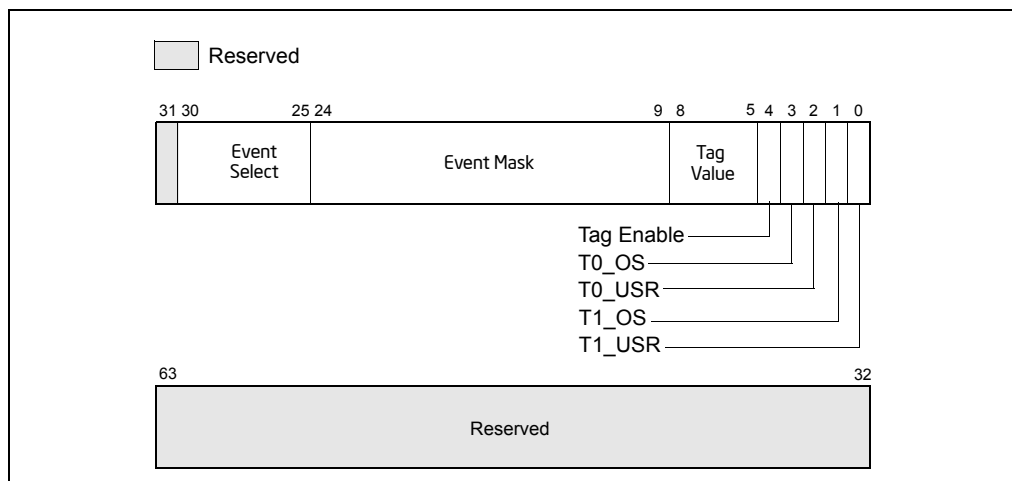
The sections below describe performance counters, event qualification by logical processor ID, and special purpose bits in ESCRs/CCCRs. They also describe MSR\_PEBS\_ENABLE, MSR\_PEBS\_MATRIX\_VERT, and MSR\_TC\_PRECISE\_EVENT.

### 18.11.1 ESCR MSRs

Figure 18-37 shows the layout of an ESCR MSR in processors supporting Intel Hyper-Threading Technology.

The functions of the flags and fields are as follows:

- T1\_USR flag, bit 0** — When set, events are counted when thread 1 (logical processor 1) is executing at a current privilege level (CPL) of 1, 2, or 3. These privilege levels are generally used by application code and unprotected operating system code.



**Figure 18-37. Event Selection Control Register (ESCR) for the Pentium 4 Processor, Intel Xeon Processor and Intel Xeon Processor MP Supporting Hyper-Threading Technology**

- T1\_OS flag, bit 1** — When set, events are counted when thread 1 (logical processor 1) is executing at CPL of 0. This privilege level is generally reserved for protected operating system code. (When both the T1\_OS and T1\_USR flags are set, thread 1 events are counted at all privilege levels.)
- T0\_USR flag, bit 2** — When set, events are counted when thread 0 (logical processor 0) is executing at a CPL of 1, 2, or 3.
- T0\_OS flag, bit 3** — When set, events are counted when thread 0 (logical processor 0) is executing at CPL of 0. (When both the T0\_OS and T0\_USR flags are set, thread 0 events are counted at all privilege levels.)

- **Tag enable, bit 4** — When set, enables tagging of  $\mu$ ops to assist in at-retirement event counting; when clear, disables tagging. See Section 18.10.6, “At-Retirement Counting.”
- **Tag value field, bits 5 through 8** — Selects a tag value to associate with a  $\mu$ op to assist in at-retirement event counting.
- **Event mask field, bits 9 through 24** — Selects events to be counted from the event class selected with the event select field.
- **Event select field, bits 25 through 30** — Selects a class of events to be counted. The events within this class that are counted are selected with the event mask field.

The T0\_OS and T0\_USR flags and the T1\_OS and T1\_USR flags allow event counting and sampling to be specified for a specific logical processor (0 or 1) within an Intel Xeon processor MP (See also: Section 8.4.5, “Identifying Logical Processors in an MP System,” in the *Intel® 64 and IA-32 Architectures Software Developer’s Manual, Volume 3A*).

Not all performance monitoring events can be detected within an Intel Xeon processor MP on a per logical processor basis (see Section 18.11.4, “Performance Monitoring Events”). Some sub-events (specified by an event mask bits) are counted or sampled without regard to which logical processor is associated with the detected event.

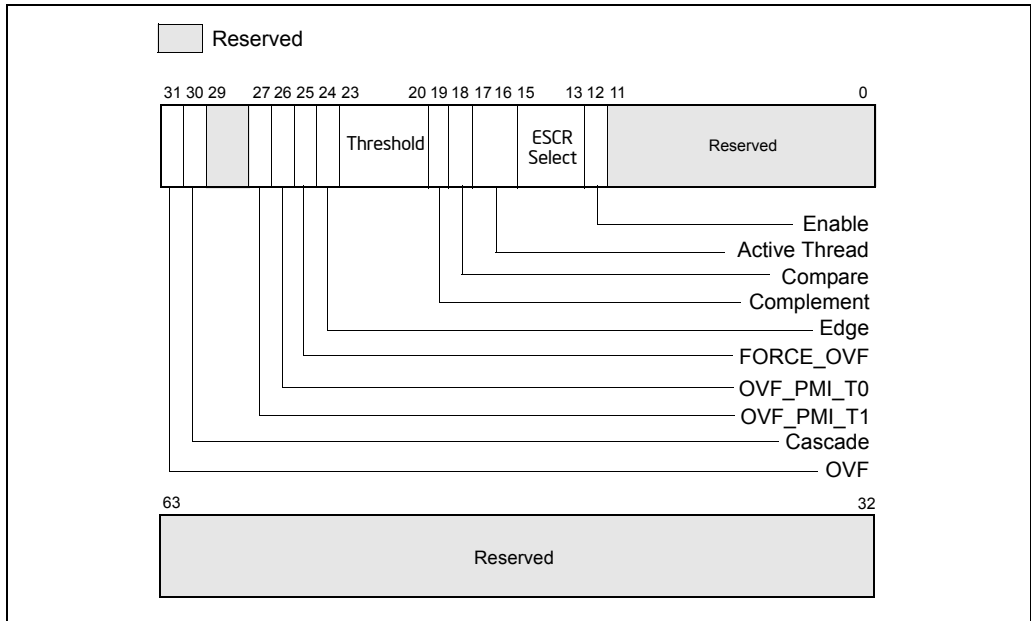
### 18.11.2 CCCR MSRs

Figure 18-38 shows the layout of a CCCR MSR in processors supporting Intel Hyper-Threading Technology. The functions of the flags and fields are as follows:

- **Enable flag, bit 12** — When set, enables counting; when clear, the counter is disabled. This flag is cleared on reset
- **ESCR select field, bits 13 through 15** — Identifies the ESCR to be used to select events to be counted with the counter associated with the CCCR.
- **Active thread field, bits 16 and 17** — Enables counting depending on which logical processors are active (executing a thread). This field enables filtering of events based on the state (active or inactive) of the logical processors. The encodings of this field are as follows:
  - 00** — None. Count only when neither logical processor is active.
  - 01** — Single. Count only when one logical processor is active (either 0 or 1).
  - 10** — Both. Count only when both logical processors are active.
  - 11** — Any. Count when either logical processor is active.

A halted logical processor or a logical processor in the “wait for SIPI” state is considered inactive.

- Compare flag, bit 18** — When set, enables filtering of the event count; when clear, disables filtering. The filtering method is selected with the threshold, complement, and edge flags.



**Figure 18-38. Counter Configuration Control Register (CCCR)**

- Complement flag, bit 19** — Selects how the incoming event count is compared with the threshold value. When set, event counts that are less than or equal to the threshold value result in a single count being delivered to the performance counter; when clear, counts greater than the threshold value result in a count being delivered to the performance counter (see Section 18.10.5.2, "Filtering Events"). The compare flag is not active unless the compare flag is set.
- Threshold field, bits 20 through 23** — Selects the threshold value to be used for comparisons. The processor examines this field only when the compare flag is set, and uses the complement flag setting to determine the type of threshold comparison to be made. The useful range of values that can be entered in this field depend on the type of event being counted (see Section 18.10.5.2, "Filtering Events").
- Edge flag, bit 24** — When set, enables rising edge (false-to-true) edge detection of the threshold comparison output for filtering event counts; when clear, rising edge detection is disabled. This flag is active only when the compare flag is set.

- **FORCE\_OVF flag, bit 25** — When set, forces a counter overflow on every counter increment; when clear, overflow only occurs when the counter actually overflows.
- **OVF\_PMI\_T0 flag, bit 26** — When set, causes a performance monitor interrupt (PMI) to be sent to logical processor 0 when the counter overflows occurs; when clear, disables PMI generation for logical processor 0. Note that the PMI is generate on the next event count after the counter has overflowed.
- **OVF\_PMI\_T1 flag, bit 27** — When set, causes a performance monitor interrupt (PMI) to be sent to logical processor 1 when the counter overflows occurs; when clear, disables PMI generation for logical processor 1. Note that the PMI is generate on the next event count after the counter has overflowed.
- **Cascade flag, bit 30** — When set, enables counting on one counter of a counter pair when its alternate counter in the other the counter pair in the same counter group overflows (see Section 18.10.2, “Performance Counters,” for further details); when clear, disables cascading of counters.
- **OVF flag, bit 31** — Indicates that the counter has overflowed when set. This flag is a sticky flag that must be explicitly cleared by software.

### 18.11.3 IA32\_PEBS\_ENABLE MSR

In a processor supporting Intel Hyper-Threading Technology and based on the Intel NetBurst microarchitecture, PEBS is enabled and qualified with two bits in the MSR\_PEBS\_ENABLE MSR: bit 25 (ENABLE\_PEBS\_MY\_THR) and 26 (ENABLE\_PEBS\_OTH\_THR) respectively. These bits do not explicitly identify a specific logical processor by logic processor ID(T0 or T1); instead, they allow a software agent to enable PEBS for subsequent threads of execution on the same logical processor on which the agent is running (“my thread”) or for the other logical processor in the physical package on which the agent is not running (“other thread”).

PEBS is supported for only a subset of the at-retirement events: Execution\_event, Front\_end\_event, and Replay\_event. Also, PEBS can be carried out only with two performance counters: MSR\_IQ\_CCCR4 (MSR address 370H) for logical processor 0 and MSR\_IQ\_CCCR5 (MSR address 371H) for logical processor 1.

Performance monitoring tools should use a processor affinity mask to bind the kernel mode components that need to modify the ENABLE\_PEBS\_MY\_THR and ENABLE\_PEBS\_OTH\_THR bits in the MSR\_PEBS\_ENABLE MSR to a specific logical processor. This is to prevent these kernel mode components from migrating between different logical processors due to OS scheduling.

### 18.11.4 Performance Monitoring Events

All of the events listed in Table 19-16 and 19-17 are available in an Intel Xeon processor MP. When Intel Hyper-Threading Technology is active, many performance monitoring events can be can be qualified by the logical processor ID, which corre-

sponds to bit 0 of the initial APIC ID. This allows for counting an event in any or all of the logical processors. However, not all the events have this logic processor specificity, or thread specificity.

Here, each event falls into one of two categories:

- **Thread specific (TS)** — The event can be qualified as occurring on a specific logical processor.
- **Thread independent (TI)** — The event cannot be qualified as being associated with a specific logical processor.

Table 19-22 gives logical processor specific information (TS or TI) for each of the events described in Tables 19-16 and 19-17. If for example, a TS event occurred in logical processor T0, the counting of the event (as shown in Table 18-34) depends only on the setting of the T0\_USR and T0\_OS flags in the ESCR being used to set up the event counter. The T1\_USR and T1\_OS flags have no effect on the count.

**Table 18-34. Effect of Logical Processor and CPL Qualification for Logical-Processor-Specific (TS) Events**

	T1_OS/T1_USR = 00	T1_OS/T1_USR = 01	T1_OS/T1_USR = 11	T1_OS/T1_USR = 10
T0_OS/T0_USR = 00	Zero count	Counts while T1 in USR	Counts while T1 in OS or USR	Counts while T1 in OS
T0_OS/T0_USR = 01	Counts while T0 in USR	Counts while T0 in USR or T1 in USR	Counts while (a) T0 in USR or (b) T1 in OS or (c) T1 in USR	Counts while (a) T0 in OS or (b) T1 in OS
T0_OS/T0_USR = 11	Counts while T0 in OS or USR	Counts while (a) T0 in OS or (b) T0 in USR or (c) T1 in USR	Counts irrespective of CPL, T0, T1	Counts while (a) T0 in OS or (b) T0 in USR or (c) T1 in OS
T0_OS/T0_USR = 10	Counts T0 in OS	Counts T0 in OS or T1 in USR	Counts while (a) T0 in OS or (b) T1 in OS or (c) T1 in USR	Counts while (a) T0 in OS or (b) T1 in OS

When a bit in the event mask field is TI, the effect of specifying bit-0-3 of the associated ESCR are described in Table 15-6. For events that are marked as TI in Chapter 19, the effect of selectively specifying T0\_USR, T0\_OS, T1\_USR, T1\_OS bits is shown in Table 18-35.

**Table 18-35. Effect of Logical Processor and CPL Qualification for Non-logical-Processor-specific (TI) Events**

	T1_OS/T1_USR = 00	T1_OS/T1_USR = 01	T1_OS/T1_USR = 11	T1_OS/T1_USR = 10
T0_OS/T0_USR = 00	Zero count	Counts while (a) T0 in USR or (b) T1 in USR	Counts irrespective of CPL, T0, T1	Counts while (a) T0 in OS or (b) T1 in OS
T0_OS/T0_USR = 01	Counts while (a) T0 in USR or (b) T1 in USR	Counts while (a) T0 in USR or (b) T1 in USR	Counts irrespective of CPL, T0, T1	Counts irrespective of CPL, T0, T1
T0_OS/T0_USR = 11	Counts irrespective of CPL, T0, T1	Counts irrespective of CPL, T0, T1	Counts irrespective of CPL, T0, T1	Counts irrespective of CPL, T0, T1
T0_OS/T0_USR = 0	Counts while (a) T0 in OS or (b) T1 in OS	Counts irrespective of CPL, T0, T1	Counts irrespective of CPL, T0, T1	Counts while (a) T0 in OS or (b) T1 in OS

## 18.12 COUNTING CLOCKS

The count of cycles, also known as clockticks, forms a the basis for measuring how long a program takes to execute. Clockticks are also used as part of efficiency ratios like cycles per instruction (CPI). Processor clocks may stop ticking under circumstances like the following:

- The processor is halted when there is nothing for the CPU to do. For example, the processor may halt to save power while the computer is servicing an I/O request. When Intel Hyper-Threading Technology is enabled, both logical processors must be halted for performance-monitoring counters to be powered down.
- The processor is asleep as a result of being halted or because of a power-management scheme. There are different levels of sleep. In the some deep sleep levels, the time-stamp counter stops counting.

In addition, processor core clocks may undergo transitions at different ratios relative to the processor's bus clock frequency. Some of the situations that can cause processor core clock to undergo frequency transitions include:

- TM2 transitions
- Enhanced Intel SpeedStep Technology transitions (P-state transitions)

For Intel processors that support Intel Dynamic Acceleration or XE operation, the processor core clocks may operate at a frequency that differs from the maximum qualified frequency (as indicated by brand string information reported by CPUID instruction). See Section 18.12.5 for more detail.



There are several ways to count processor clock cycles to monitor performance. These are:

- **Non-halted clockticks** — Measures clock cycles in which the specified logical processor is not halted and is not in any power-saving state. When Intel Hyper-Threading Technology is enabled, ticks can be measured on a per-logical-processor basis. There are also performance events on dual-core processors that measure clockticks per logical processor when the processor is not halted.
- **Non-sleep clockticks** — Measures clock cycles in which the specified physical processor is not in a sleep mode or in a power-saving state. These ticks cannot be measured on a logical-processor basis.
- **Time-stamp counter** — Measures clock cycles in which the physical processor is not in deep sleep. These ticks cannot be measured on a logical-processor basis.
- **Reference clockticks** — TM2 or Enhanced Intel SpeedStep technology are two examples of processor features that can cause processor core clockticks to represent non-uniform tick intervals due to change of bus ratios. Performance events that counts clockticks of a constant reference frequency was introduced Intel Core Duo and Intel Core Solo processors. The mechanism is further enhanced on processors based on Intel Core microarchitecture.

Some processor models permit clock cycles to be measured when the physical processor is not in deep sleep (by using the time-stamp counter and the RDTSC instruction). Note that such ticks cannot be measured on a per-logical-processor basis. See Section 17.12, "Time-Stamp Counter," for detail on processor capabilities.

The first two methods use performance counters and can be set up to cause an interrupt upon overflow (for sampling). They may also be useful where it is easier for a tool to read a performance counter than to use a time stamp counter (the timestamp counter is accessed using the RDTSC instruction).

For applications with a significant amount of I/O, there are two ratios of interest:

- **Non-halted CPI** — Non-halted clockticks/instructions retired measures the CPI for phases where the CPU was being used. This ratio can be measured on a logical-processor basis when Intel Hyper-Threading Technology is enabled.
- **Nominal CPI** — Time-stamp counter ticks/instructions retired measures the CPI over the duration of a program, including those periods when the machine halts while waiting for I/O.

### 18.12.1 Non-Halted Clockticks

Use the following procedure to program ESCRs and CCCRs to obtain non-halted clockticks on processors based on Intel NetBurst microarchitecture:

1. Select an ESCR for the `global_power_events` and specify the `RUNNING` sub-event mask and the desired `T0_OS/T0_USR/T1_OS/T1_USR` bits for the targeted processor.

2. Select an appropriate counter.
3. Enable counting in the CCCR for that counter by setting the enable bit.

### 18.12.2 Non-Sleep Clockticks

Performance monitoring counters can be configured to count clockticks whenever the performance monitoring hardware is not powered-down. To count Non-sleep Clockticks with a performance-monitoring counter, do the following:

1. Select one of the 18 counters.
2. Select any of the ESCRs whose events the selected counter can count. Set its event select to anything other than `no_event`. This may not seem necessary, but the counter may be disabled if this is not done.
3. Turn threshold comparison on in the CCCR by setting the compare bit to 1.
4. Set the threshold to 15 and the complement to 1 in the CCCR. Since no event can exceed this threshold, the threshold condition is met every cycle and the counter counts every cycle. Note that this overrides any qualification (e.g. by CPL) specified in the ESCR.
5. Enable counting in the CCCR for the counter by setting the enable bit.

In most cases, the counts produced by the non-halted and non-sleep metrics are equivalent if the physical package supports one logical processor and is not placed in a power-saving state. Operating systems may execute an HLT instruction and place a physical processor in a power-saving state.

On processors that support Intel Hyper-Threading Technology (Intel HT Technology), each physical package can support two or more logical processors. Current implementation of Intel HT Technology provides two logical processors for each physical processor. While both logical processors can execute two threads simultaneously, one logical processor may halt to allow the other logical processor to execute without sharing execution resources between two logical processors.

Non-halted Clockticks can be set up to count the number of processor clock cycles for each logical processor whenever the logical processor is not halted (the count may include some portion of the clock cycles for that logical processor to complete a transition to a halted state). Physical processors that support Intel HT Technology enter into a power-saving state if all logical processors halt.

The Non-sleep Clockticks mechanism uses a filtering mechanism in CCCRs. The mechanism will continue to increment as long as one logical processor is not halted or in a power-saving state. Applications may cause a processor to enter into a power-saving state by using an OS service that transfers control to an OS's idle loop. The idle loop then may place the processor into a power-saving state after an implementation-dependent period if there is no work for the processor.

### 18.12.3 Incrementing the Time-Stamp Counter

The time-stamp counter increments when the clock signal on the system bus is active and when the sleep pin is not asserted. The counter value can be read with the RDTSC instruction.

The time-stamp counter and the non-sleep clockticks count may not agree in all cases and for all processors. See Section 17.12, “Time-Stamp Counter,” for more information on counter operation.

### 18.12.4 Non-Halted Reference Clockticks

Software can use either processor-specific performance monitor events (for example: CPU\_CLK\_UNHALTED.BUS on processors based on the Intel Core microarchitecture, and equivalent event specifications on the Intel Core Duo and Intel Core Solo processors) to count non-halted reference clockticks.

These events count reference clock cycles whenever the specified processor is not halted. The counter counts reference cycles associated with a fixed-frequency clock source irrespective of P-state, TM2, or frequency transitions that may occur to the processor.

### 18.12.5 Cycle Counting and Opportunistic Processor Operation

As a result of the state transitions due to opportunistic processor performance operation (see Chapter 14, “Power and Thermal Management”), a logical processor or a processor core can operate at frequency different from that indicated by the processor’s maximum qualified frequency.

The following items are expected to hold true irrespective of when opportunistic processor operation causes state transitions:

- The time stamp counter operates at a fixed-rate frequency of the processor.
- The IA32\_MPERF counter increments at the same TSC frequency irrespective of any transitions caused by opportunistic processor operation.
- The IA32\_FIXED\_CTR2 counter increments at the same TSC frequency irrespective of any transitions caused by opportunistic processor operation.
- The Local APIC timer operation is unaffected by opportunistic processor operation.
- The TSC, IA32\_MPERF, and IA32\_FIXED\_CTR2 operate at the same, maximum-resolved frequency of the platform, which is equal to the product of scalable bus frequency and maximum resolved bus ratio.

For processors based on Intel Core microarchitecture, the scalable bus frequency is encoded in the bit field MSR\_FSB\_FREQ[2:0] at (0CDH), see Chapter 34, “Model-

Specific Registers (MSRs)”. The maximum resolved bus ratio can be read from the following bit field:

- If XE operation is disabled, the maximum resolved bus ratio can be read in MSR\_PLATFORM\_ID[12:8]. It corresponds to the maximum qualified frequency.
- If XE operation is enabled, the maximum resolved bus ratio is given in MSR\_PERF\_STAT[44:40], it corresponds to the maximum XE operation frequency configured by BIOS.

XE operation of an Intel 64 processor is implementation specific. XE operation can be enabled only by BIOS. If MSR\_PERF\_STAT[31] is set, XE operation is enabled. The MSR\_PERF\_STAT[31] field is read-only.

## 18.13 PERFORMANCE MONITORING, BRANCH PROFILING AND SYSTEM EVENTS

When performance monitoring facilities and/or branch profiling facilities (see Section 17.5, “Last Branch, Interrupt, and Exception Recording (Intel® Core™2 Duo and Intel® Atom™ Processor Family)”) are enabled, these facilities capture event counts, branch records and branch trace messages occurring in a logical processor. The occurrence of interrupts, instruction streams due to various interrupt handlers all contribute to the results recorded by these facilities.

If CPUID.01H:ECX.PDCM[bit 15] is 1, the processor supports the IA32\_PERF\_CAPABILITIES MSR. If

IA32\_PERF\_CAPABILITIES.FREEZE\_WHILE\_SMM[Bit 12] is 1, the processor supports the ability for system software using performance monitoring and/or branch profiling facilities to filter out the effects of servicing system management interrupts.

If the FREEZE\_WHILE\_SMM capability is enabled on a logical processor and after an SMI is delivered, the processor will clear all the enable bits of IA32\_PERF\_GLOBAL\_CTRL, save a copy of the content of IA32\_DEBUGCTL and disable LBR, BTF, TR, and BTS fields of IA32\_DEBUGCTL before transferring control to the SMI handler.

The enable bits of IA32\_PERF\_GLOBAL\_CTRL will be set to 1, the saved copy of IA32\_DEBUGCTL prior to SMI delivery will be restored, after the SMI handler issues RSM to complete its servicing.

It is the responsibility of the SMM code to ensure the state of the performance monitoring and branch profiling facilities are preserved upon entry or until prior to exiting the SMM. If any of this state is modified due to actions by the SMM code, the SMM code is required to restore such state to the values present at entry to the SMM handler.

System software is allowed to set IA32\_DEBUGCTL.FREEZE\_WHILE\_SMM\_EN[bit 14] to 1 only supported as indicated by IA32\_PERF\_CAPABILITIES.FREEZE\_WHILE\_SMM[Bit 12] reporting 1.

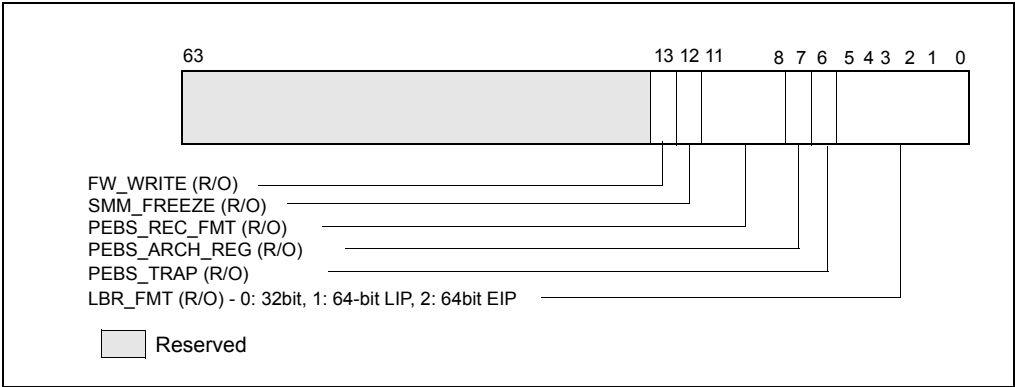


Figure 18-39. Layout of IA32\_PERF\_CAPABILITIES MSR

### 18.14 PERFORMANCE MONITORING AND DUAL-CORE TECHNOLOGY

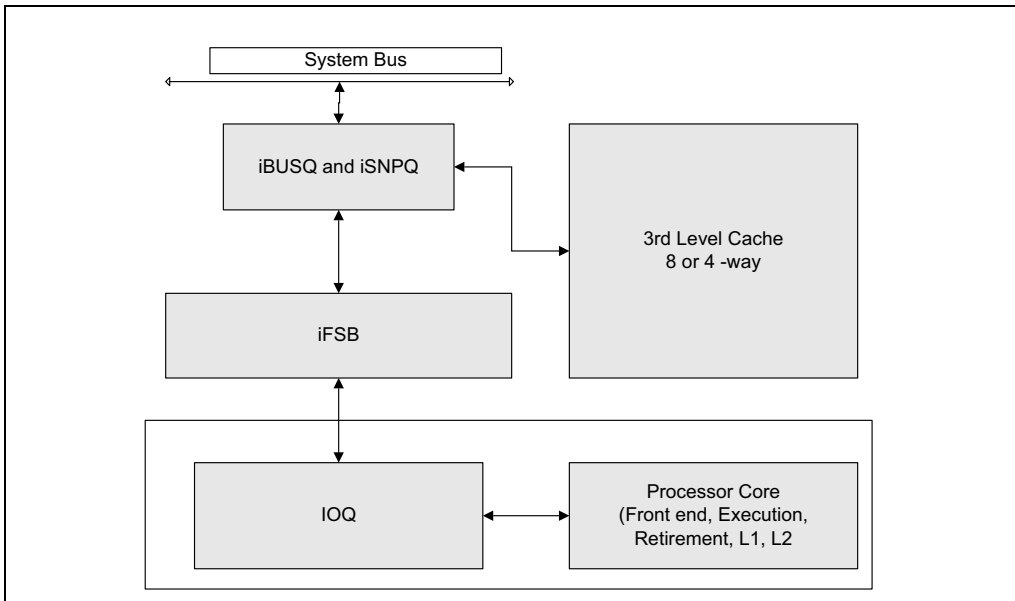
The performance monitoring capability of dual-core processors duplicates the microarchitectural resources of a single-core processor implementation. Each processor core has dedicated performance monitoring resources.

In the case of Pentium D processor, each logical processor is associated with dedicated resources for performance monitoring. In the case of Pentium processor Extreme edition, each processor core has dedicated resources, but two logical processors in the same core share performance monitoring resources (see Section 18.11, "Performance Monitoring and Intel Hyper-Threading Technology in Processors Based on Intel NetBurst® Microarchitecture").

### 18.15 PERFORMANCE MONITORING ON 64-BIT INTEL XEON PROCESSOR MP WITH UP TO 8-MBYTE L3 CACHE

The 64-bit Intel Xeon processor MP with up to 8-MByte L3 cache has a CPUID signature of family [0FH], model [03H or 04H]. Performance monitoring capabilities available to Pentium 4 and Intel Xeon processors with the same values (see Section 18.1 and Section 18.11) apply to the 64-bit Intel Xeon processor MP with an L3 cache.

The level 3 cache is connected between the system bus and IOQ through additional control logic. See Figure 18-40.



**Figure 18-40. Block Diagram of 64-bit Intel Xeon Processor MP with 8-MByte L3**

Additional performance monitoring capabilities and facilities unique to 64-bit Intel Xeon processor MP with an L3 cache are described in this section. The facility for monitoring events consists of a set of dedicated model-specific registers (MSRs), each dedicated to a specific event. Programming of these MSRs requires using RDMSR/WRMSR instructions with 64-bit values.

The lower 32-bits of the MSRs at addresses 107CC through 107D3 are treated as 32 bit performance counter registers. These performance counters can be accessed using RDPMC instruction with the index starting from 18 through 25. The EDX register returns zero when reading these 8 PMCs.

The performance monitoring capabilities consist of four events. These are:

- **IBUSQ event** — This event detects the occurrence of micro-architectural conditions related to the iBUSQ unit. It provides two MSRs: MSR\_IFSB\_IBUSQ0 and MSR\_IFSB\_IBUSQ1. Configure sub-event qualification and enable/disable functions using the high 32 bits of these MSRs. The low 32 bits act as a 32-bit event counter. Counting starts after software writes a non-zero value to one or more of the upper 32 bits. See Figure 18-41.

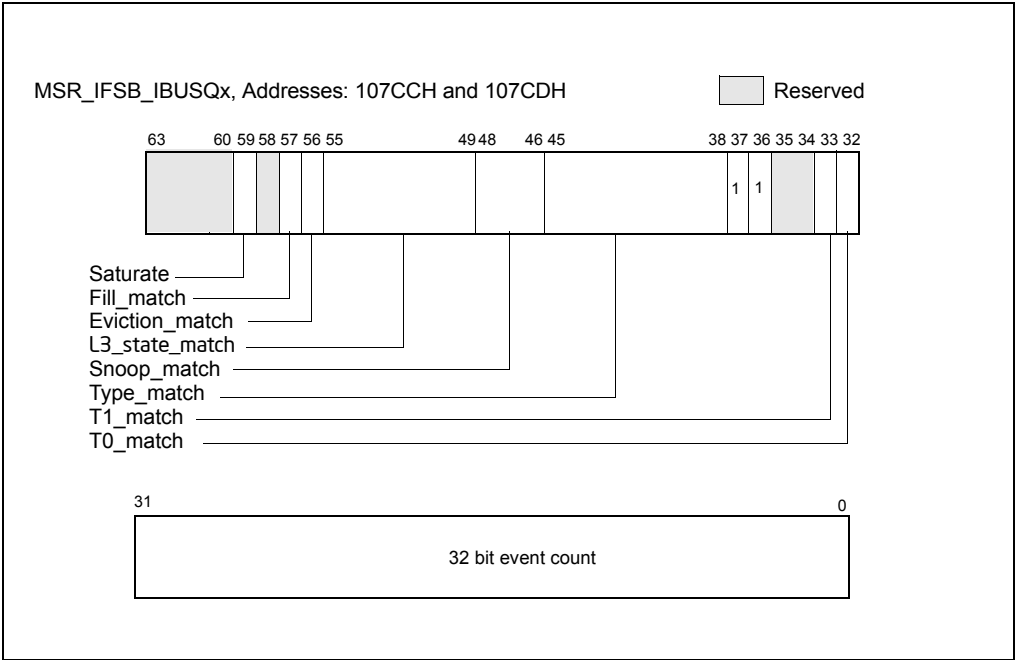
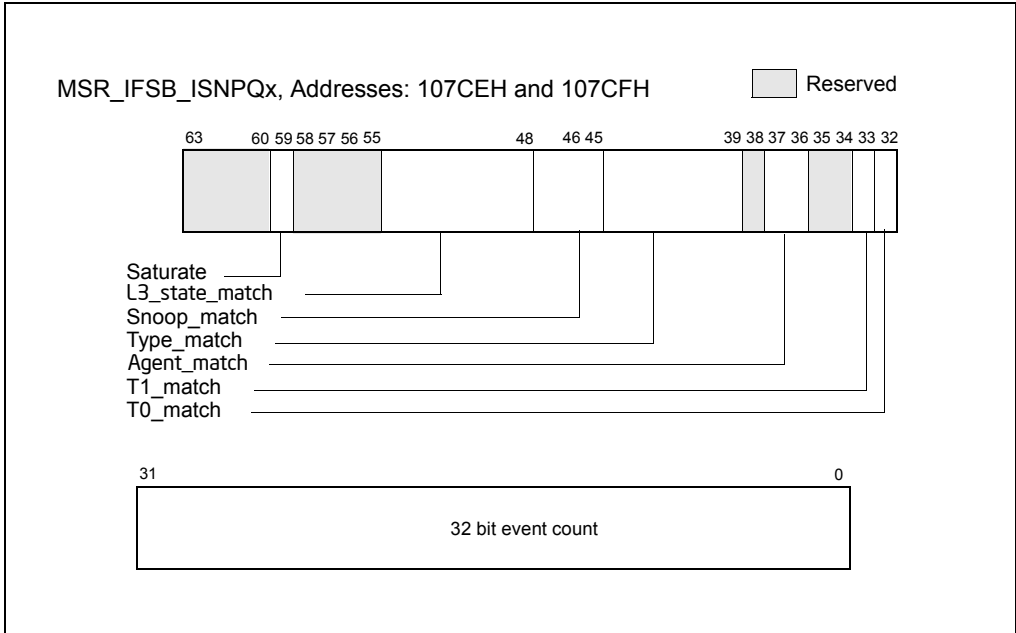


Figure 18-41. MSR\_IFSB\_IBUSQx, Addresses: 107CCH and 107CDH

- ISNPQ event** — This event detects the occurrence of microarchitectural conditions related to the iSNPQ unit. It provides two MSRs: MSR\_IFSB\_ISNPQ0 and MSR\_IFSB\_ISNPQ1. Configure sub-event qualifications and enable/disable functions using the high 32 bits of the MSRs. The low 32-bits act as a 32-bit event counter. Counting starts after software writes a non-zero value to one or more of the upper 32-bits. See Figure 18-42.



**Figure 18-42. MSR\_IFSB\_ISNPQx, Addresses: 107CEH and 107CFH**

- EFSB event** — This event can detect the occurrence of micro-architectural conditions related to the iFSB unit or system bus. It provides two MSRs: MSR\_EFSB\_DRDY0 and MSR\_EFSB\_DRDY1. Configure sub-event qualifications and enable/disable functions using the high 32 bits of the 64-bit MSR. The low 32-bit act as a 32-bit event counter. Counting starts after software writes a non-zero value to one or more of the qualification bits in the upper 32-bits of the MSR. See Figure 18-43.



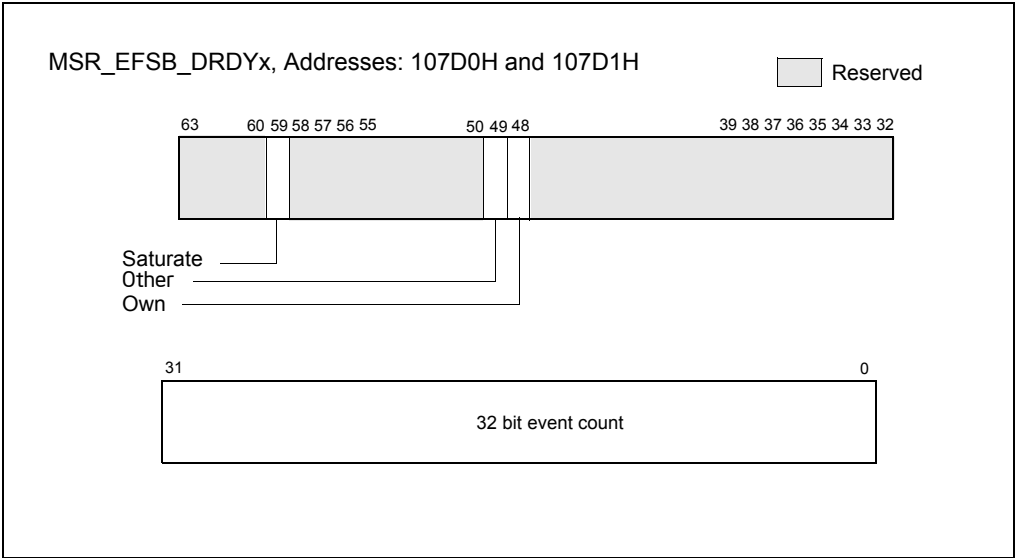
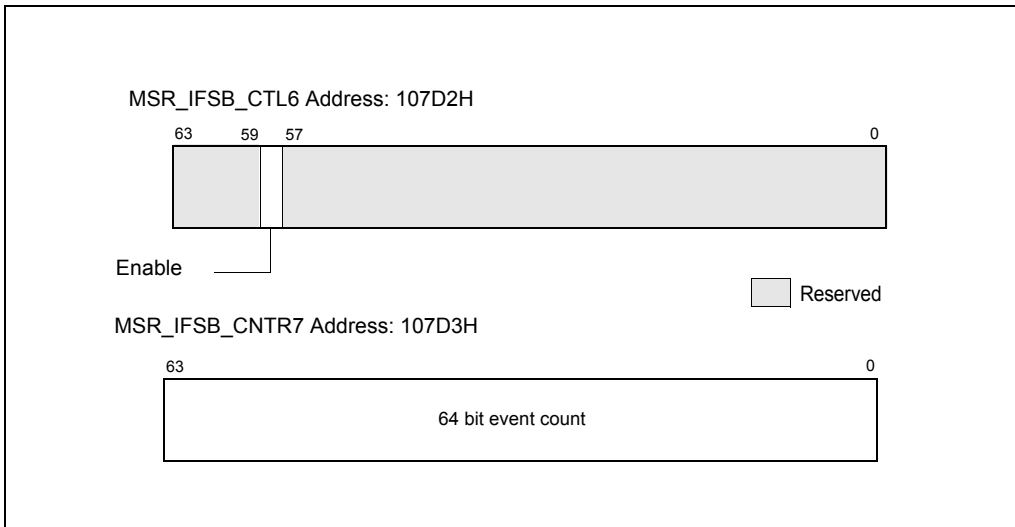


Figure 18-43. MSR\_EFSB\_DRDYx, Addresses: 107D0H and 107D1H

- **IBUSQ Latency event** — This event accumulates weighted cycle counts for latency measurement of transactions in the iBUSQ unit. The count is enabled by setting MSR\_IFSB\_CTRL6[bit 26] to 1; the count freezes after software sets MSR\_IFSB\_CTRL6[bit 26] to 0. MSR\_IFSB\_CNTR7 acts as a 64-bit event counter for this event. See Figure 18-44.



**Figure 18-44. MSR\_IFSB\_CTL6, Address: 107D2H;  
MSR\_IFSB\_CNTR7, Address: 107D3H**

## 18.16 PERFORMANCE MONITORING ON L3 AND CACHING BUS CONTROLLER SUB-SYSTEMS

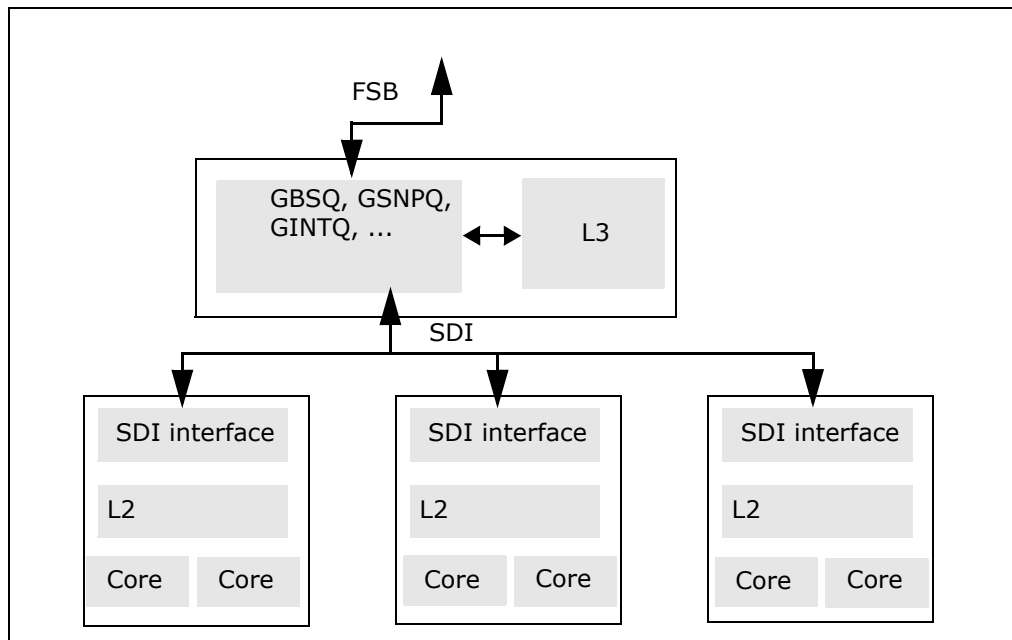
The Intel Xeon processor 7400 series and Dual-Core Intel Xeon processor 7100 series employ a distinct L3/caching bus controller sub-system. These sub-systems have a unique set of performance monitoring capability and programming interfaces that are largely common between these two processor families.

Intel Xeon processor 7400 series are based on 45nm enhanced Intel Core microarchitecture. The CPUID signature is indicated by DisplayFamily\_DisplayModel value of 06\_1DH (see CPUID instruction in Chapter 3, "Instruction Set Reference, A-L" in the *Intel® 64 and IA-32 Architectures Software Developer's Manual, Volume 2A*). Intel Xeon processor 7400 series have six processor cores that share an L3 cache.

Dual-Core Intel Xeon processor 7100 series are based on Intel NetBurst microarchitecture, have a CPUID signature of family [0FH], model [06H] and a unified L3 cache shared between two cores. Each core in an Intel Xeon processor 7100 series supports Intel Hyper-Threading Technology, providing two logical processors per core.

Both Intel Xeon processor 7400 series and Intel Xeon processor 7100 series support multi-processor configurations using system bus interfaces. In Intel Xeon processor 7400 series, the L3/caching bus controller sub-system provides three Simple Direct Interface (SDI) to service transactions originated the XQ-replacement SDI logic in each dual-core modules. In Intel Xeon processor 7100 series, the IOQ logic in each processor core is replaced with a Simple Direct Interface (SDI) logic. The L3 cache is

connected between the system bus and the SDI through additional control logic. See Figure 18-45 for the block configuration of six processor cores and the L3/Caching bus controller sub-system in Intel Xeon processor 7400 series. Figure 18-45 shows the block configuration of two processor cores (four logical processors) and the L3/Caching bus controller sub-system in Intel Xeon processor 7100 series.



**Figure 18-45. Block Diagram of Intel Xeon Processor 7400 Series**

Almost all of the performance monitoring capabilities available to processor cores with the same CPUID signatures (see Section 18.1 and Section 18.11) apply to Intel Xeon processor 7100 series. The MSRs used by performance monitoring interface are shared between two logical processors in the same processor core.

The performance monitoring capabilities available to processor with DisplayFamily\_DisplayModel signature 06\_17H also apply to Intel Xeon processor 7400 series. Each processor core provides its own set of MSRs for performance monitoring interface.

The IOQ\_allocation and IOQ\_active\_entries events are not supported in Intel Xeon processor 7100 series and 7400 series. Additional performance monitoring capabilities applicable to the L3/caching bus controller sub-system are described in this section.

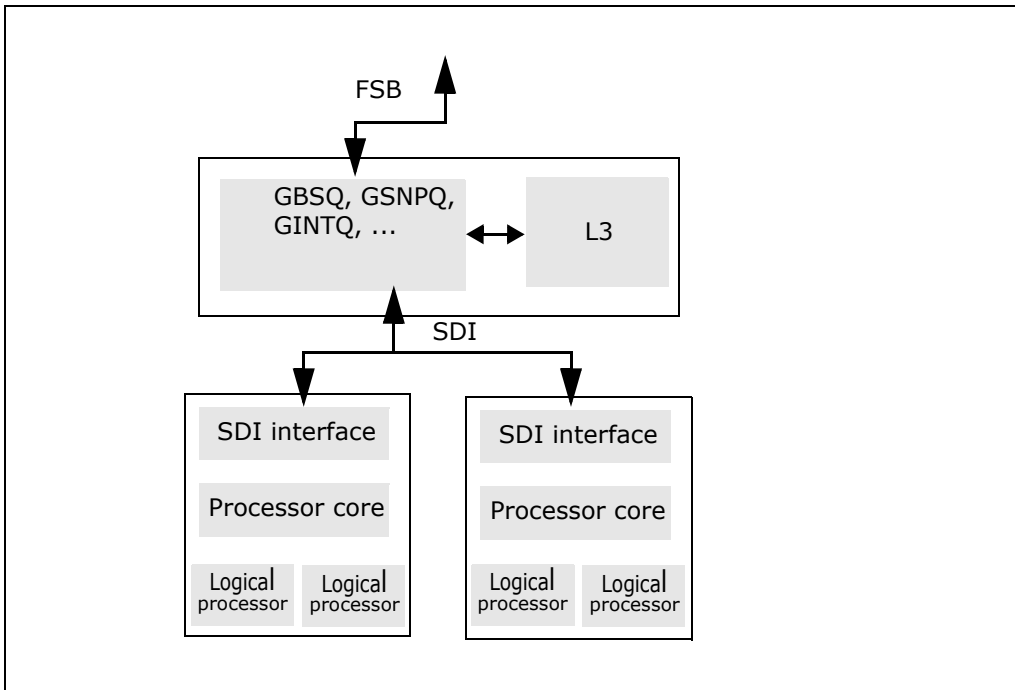


Figure 18-46. Block Diagram of Intel Xeon Processor 7100 Series

### 18.16.1 Overview of Performance Monitoring with L3/Caching Bus Controller

The facility for monitoring events consists of a set of dedicated model-specific registers (MSRs). There are eight event select/counting MSRs that are dedicated to counting events associated with specified microarchitectural conditions. Programming of these MSRs requires using RDMSR/WRMSR instructions with 64-bit values. In addition, an MSR MSR\_EMON\_L3\_GL\_CTL provides simplified interface to control freezing, resetting, re-enabling operation of any combination of these event select/counting MSRs.

The eight MSRs dedicated to count occurrences of specific conditions are further divided to count three sub-classes of microarchitectural conditions:

- Two MSRs (MSR\_EMON\_L3\_CTR\_CTL0 and MSR\_EMON\_L3\_CTR\_CTL1) are dedicated to counting GBSQ events. Up to two GBSQ events can be programmed and counted simultaneously.
- Two MSRs (MSR\_EMON\_L3\_CTR\_CTL2 and MSR\_EMON\_L3\_CTR\_CTL3) are dedicated to counting GSNPQ events. Up to two GBSQ events can be programmed and counted simultaneously.

- Four MSRs (MSR\_EMON\_L3\_CTR\_CTL4, MSR\_EMON\_L3\_CTR\_CTL5, MSR\_EMON\_L3\_CTR\_CTL6, and MSR\_EMON\_L3\_CTR\_CTL7) are dedicated to counting external bus operations.

The bit fields in each of eight MSRs share the following common characteristics:

- Bits 63:32 is the event control field that includes an event mask and other bit fields that control counter operation. The event mask field specifies details of the microarchitectural condition, and its definition differs across GBSQ, GSNPQ, FSB.
- Bits 31:0 is the event count field. If the specified condition is met during each relevant clock domain of the event logic, the matched condition signals the counter logic to increment the associated event count field. The lower 32-bits of these 8 MSRs at addresses 107CC through 107D3 are treated as 32 bit performance counter registers.

In Dual-Core Intel Xeon processor 7100 series, the uncore performance counters can be accessed using RDPMC instruction with the index starting from 18 through 25. The EDX register returns zero when reading these 8 PMCs.

In Intel Xeon processor 7400 series, RDPMC with ECX between 2 and 9 can be used to access the eight uncore performance counter/control registers.

### 18.16.2 GBSQ Event Interface

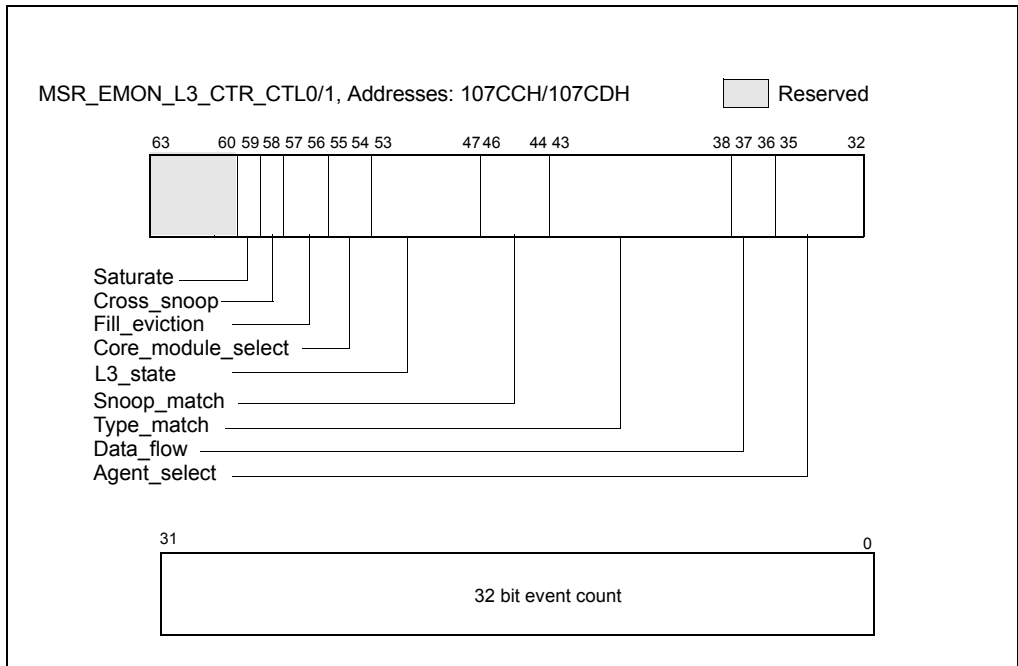
The layout of MSR\_EMON\_L3\_CTR\_CTL0 and MSR\_EMON\_L3\_CTR\_CTL1 is given in Figure 18-47. Counting starts after software writes a non-zero value to one or more of the upper 32 bits.

The event mask field (bits 58:32) consists of the following eight attributes:

- Agent\_Select (bits 35:32): The definition of this field differs slightly between Intel Xeon processor 7100 and 7400.

For Intel Xeon processor 7100 series, each bit specifies a logical processor in the physical package. The lower two bits corresponds to two logical processors in the first processor core, the upper two bits corresponds to two logical processors in the second processor core. 0FH encoding matches transactions from any logical processor.

For Intel Xeon processor 7400 series, each bit of [34:32] specifies the SDI logic of a dual-core module as the originator of the transaction. A value of 0111B in bits [35:32] specifies transaction from any processor core.



**Figure 18-47. MSR\_EMON\_L3\_CTR\_CTL0/1, Addresses: 107CCH/107CDH**

- Data\_Flow (bits 37:36): Bit 36 specifies demand transactions, bit 37 specifies prefetch transactions.
- Type\_Match (bits 43:38): Specifies transaction types. If all six bits are set, event count will include all transaction types.
- Snoop\_Match: (bits 46:44): The three bits specify (in ascending bit position) clean snoop result, HIT snoop result, and HITM snoop results respectively.
- L3\_State (bits 53:47): Each bit specifies an L2 coherency state.
- Core\_Module\_Select (bits 55:54): The valid encodings for L3 lookup differ slightly between Intel Xeon processor 7100 and 7400.
  - For Intel Xeon processor 7100 series,
    - 00B: Match transactions from any core in the physical package
    - 01B: Match transactions from this core only
    - 10B: Match transactions from the other core in the physical package
    - 11B: Match transaction from both cores in the physical package
  - For Intel Xeon processor 7400 series,
    - 00B: Match transactions from any dual-core module in the physical package

- 01B: Match transactions from this dual-core module only
- 10B: Match transactions from either one of the other two dual-core modules in the physical package
- 11B: Match transaction from more than one dual-core modules in the physical package
- Fill\_Eviction (bits 57:56): The valid encodings are
  - 00B: Match any transactions
  - 01B: Match transactions that fill L3
  - 10B: Match transactions that fill L3 without an eviction
  - 11B: Match transaction fill L3 with an eviction
- Cross\_Snoop (bit 58): The encodings are
  - 0B: Match any transactions
  - 1B: Match cross snoop transactions

For each counting clock domain, if all eight attributes match, event logic signals to increment the event count field.

### 18.16.3 GSNPQ Event Interface

The layout of MSR\_EMON\_L3\_CTR\_CTL2 and MSR\_EMON\_L3\_CTR\_CTL3 is given in Figure 18-48. Counting starts after software writes a non-zero value to one or more of the upper 32 bits.

The event mask field (bits 58:32) consists of the following six attributes:

- Agent\_Select (bits 37:32): The definition of this field differs slightly between Intel Xeon processor 7100 and 7400.
- For Intel Xeon processor 7100 series, each of the lowest 4 bits specifies a logical processor in the physical package. The lowest two bits corresponds to two logical processors in the first processor core, the next two bits corresponds to two logical processors in the second processor core. Bit 36 specifies other symmetric agent transactions. Bit 37 specifies central agent transactions. 3FH encoding matches transactions from any logical processor.  
For Intel Xeon processor 7400 series, each of the lowest 3 bits specifies a dual-core module in the physical package. Bit 37 specifies central agent transactions.
- Type\_Match (bits 43:38): Specifies transaction types. If all six bits are set, event count will include any transaction types.
- Snoop\_Match: (bits 46:44): The three bits specify (in ascending bit position) clean snoop result, HIT snoop result, and HITM snoop results respectively.
- L2\_State (bits 53:47): Each bit specifies an L3 coherency state.
- Core\_Module\_Select (bits 56:54): Bit 56 enables Core\_Module\_Select matching. If bit 56 is clear, Core\_Module\_Select encoding is ignored. The valid encodings for

the lower two bits (bit 55, 54) differ slightly between Intel Xeon processor 7100 and 7400.

For Intel Xeon processor 7100 series, if bit 56 is set, the valid encodings for the lower two bits (bit 55, 54) are

- 00B: Match transactions from only one core (irrespective which core) in the physical package
- 01B: Match transactions from this core and not the other core
- 10B: Match transactions from the other core in the physical package, but not this core
- 11B: Match transaction from both cores in the physical package

For Intel Xeon processor 7400 series, if bit 56 is set, the valid encodings for the lower two bits (bit 55, 54) are

- 00B: Match transactions from only one dual-core module (irrespective which module) in the physical package
  - 01B: Match transactions from one or more dual-core modules.
  - 10B: Match transactions from two or more dual-core modules.
  - 11B: Match transaction from all three dual-core modules in the physical package
- Block\_Snoop (bit 57): specifies blocked snoop.

For each counting clock domain, if all six attributes match, event logic signals to increment the event count field.



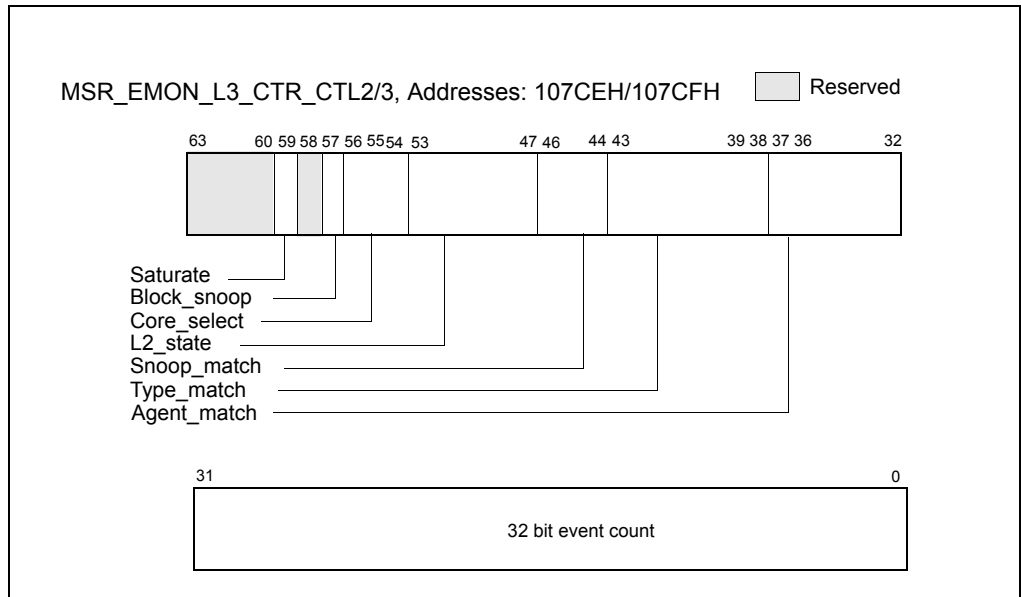


Figure 18-48. MSR\_EMON\_L3\_CTR\_CTL2/3, Addresses: 107CEH/107CFH

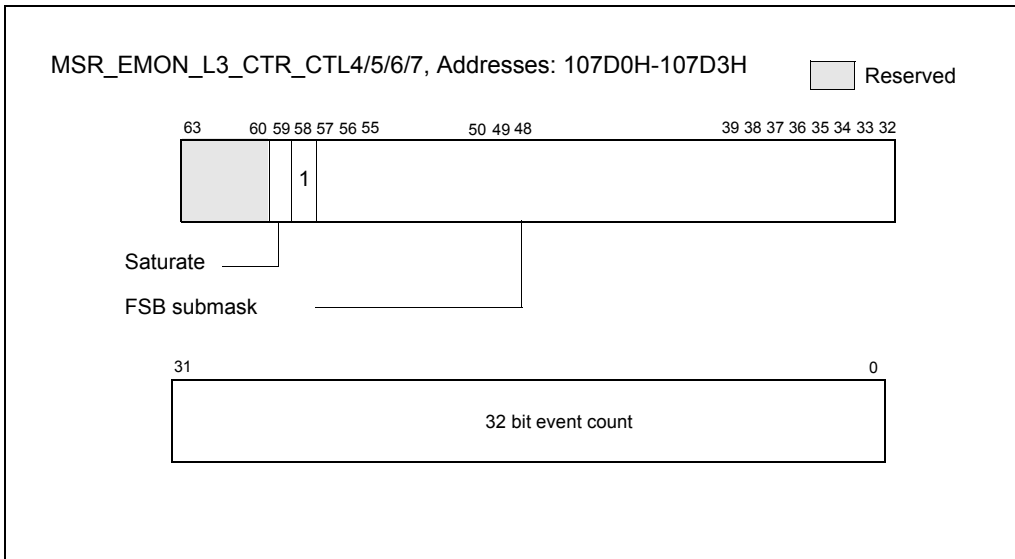
### 18.16.4 FSB Event Interface

The layout of MSR\_EMON\_L3\_CTR\_CTL4 through MSR\_EMON\_L3\_CTR\_CTL7 is given in Figure 18-49. Counting starts after software writes a non-zero value to one or more of the upper 32 bits.

The event mask field (bits 58:32) is organized as follows:

- Bit 58: must set to 1.
- FSB\_Submask (bits 57:32): Specifies FSB-specific sub-event mask.

The FSB sub-event mask defines a set of independent attributes. The event logic signals to increment the associated event count field if one of the attribute matches. Some of the sub-event mask bit counts durations. A duration event increments at most once per cycle.



**Figure 18-49. MSR\_EMON\_L3\_CTR\_CTL4/5/6/7, Addresses: 107D0H-107D3H**

#### 18.16.4.1 FSB Sub-Event Mask Interface

- FSB\_type (bit 37:32): Specifies different FSB transaction types originated from this physical package
- FSB\_L\_clear (bit 38): Count clean snoop results from any source for transaction originated from this physical package
- FSB\_L\_hit (bit 39): Count HIT snoop results from any source for transaction originated from this physical package
- FSB\_L\_hitm (bit 40): Count HITM snoop results from any source for transaction originated from this physical package
- FSB\_L\_defer (bit 41): Count DEFER responses to this processor's transactions
- FSB\_L\_retry (bit 42): Count RETRY responses to this processor's transactions
- FSB\_L\_snoop\_stall (bit 43): Count snoop stalls to this processor's transactions
- FSB\_DBSY (bit 44): Count DBSY assertions by this processor (without a concurrent DRDY)
- FSB\_DRDY (bit 45): Count DRDY assertions by this processor
- FSB\_BNR (bit 46): Count BNR assertions by this processor
- FSB\_IOQ\_empty (bit 47): Counts each bus clocks when the IOQ is empty
- FSB\_IOQ\_full (bit 48): Counts each bus clocks when the IOQ is full
- FSB\_IOQ\_active (bit 49): Counts each bus clocks when there is at least one entry in the IOQ

- FSB\_WW\_data (bit 50): Counts back-to-back write transaction's data phase.
- FSB\_WW\_issue (bit 51): Counts back-to-back write transaction request pairs issued by this processor.
- FSB\_WR\_issue (bit 52): Counts back-to-back write-read transaction request pairs issued by this processor.
- FSB\_RW\_issue (bit 53): Counts back-to-back read-write transaction request pairs issued by this processor.
- FSB\_other\_DBSY (bit 54): Count DBSY assertions by another agent (without a concurrent DRDY)
- FSB\_other\_DRDY (bit 55): Count DRDY assertions by another agent
- FSB\_other\_snoop\_stall (bit 56): Count snoop stalls on the FSB due to another agent
- FSB\_other\_BNR (bit 57): Count BNR assertions from another agent

### 18.16.5 Common Event Control Interface

The MSR\_EMON\_L3\_GL\_CTL MSR provides simplified access to query overflow status of the GBSQ, GSNPQ, FSB event counters. It also provides control bit fields to freeze, unfreeze, or reset those counters. The following bit fields are supported:

- GL\_freeze\_cmd (bit 0): Freeze the event counters specified by the GL\_event\_select field.
- GL\_unfreeze\_cmd (bit 1): Unfreeze the event counters specified by the GL\_event\_select field.
- GL\_reset\_cmd (bit 2): Clear the event count field of the event counters specified by the GL\_event\_select field. The event select field is not affected.
- GL\_event\_select (bit 23:16): Selects one or more event counters to subject to specified command operations indicated by bits 2:0. Bit 16 corresponds to MSR\_EMON\_L3\_CTR\_CTL0, bit 23 corresponds to MSR\_EMON\_L3\_CTR\_CTL7.
- GL\_event\_status (bit 55:48): Indicates the overflow status of each event counters. Bit 48 corresponds to MSR\_EMON\_L3\_CTR\_CTL0, bit 55 corresponds to MSR\_EMON\_L3\_CTR\_CTL7.

In the event control field (bits 63:32) of each MSR, if the saturate control (bit 59, see Figure 18-47 for example) is set, the event logic forces the value FFFF\_FFFFH into the event count field instead of incrementing it.

## 18.17 PERFORMANCE MONITORING (P6 FAMILY PROCESSOR)

The P6 family processors provide two 40-bit performance counters, allowing two types of events to be monitored simultaneously. These can either count events or

measure duration. When counting events, a counter increments each time a specified event takes place or a specified number of events takes place. When measuring duration, it counts the number of processor clocks that occur while a specified condition is true. The counters can count events or measure durations that occur at any privilege level.

Table 19-25, Chapter 19, lists the events that can be counted with the P6 family performance monitoring counters.

### NOTE

The performance-monitoring events listed in Chapter 19 are intended to be used as guides for performance tuning. Counter values reported are not guaranteed to be accurate and should be used as a relative guide for tuning. Known discrepancies are documented where applicable.

The performance-monitoring counters are supported by four MSR: the performance event select MSRs (PerfEvtSel0 and PerfEvtSel1) and the performance counter MSRs (PerfCtr0 and PerfCtr1). These registers can be read from and written to using the RDMSR and WRMSR instructions, respectively. They can be accessed using these instructions only when operating at privilege level 0. The PerfCtr0 and PerfCtr1 MSRs can be read from any privilege level using the RDPMC (read performance-monitoring counters) instruction.

### NOTE

The PerfEvtSel0, PerfEvtSel1, PerfCtr0, and PerfCtr1 MSRs and the events listed in Table 19-25 are model-specific for P6 family processors. They are not guaranteed to be available in other IA-32 processors.

## 18.17.1 PerfEvtSel0 and PerfEvtSel1 MSRs

The PerfEvtSel0 and PerfEvtSel1 MSRs control the operation of the performance-monitoring counters, with one register used to set up each counter. They specify the events to be counted, how they should be counted, and the privilege levels at which counting should take place. Figure 18-50 shows the flags and fields in these MSRs.

The functions of the flags and fields in the PerfEvtSel0 and PerfEvtSel1 MSRs are as follows:

- **Event select field (bits 0 through 7)** — Selects the event logic unit to detect certain microarchitectural conditions (see Table 19-25, for a list of events and their 8-bit codes).
- **Unit mask (UMASK) field (bits 8 through 15)** — Further qualifies the event logic unit selected in the event select field to detect a specific microarchitectural condition. For example, for some cache events, the mask is used as a MESI-protocol qualifier of cache states (see Table 19-25).

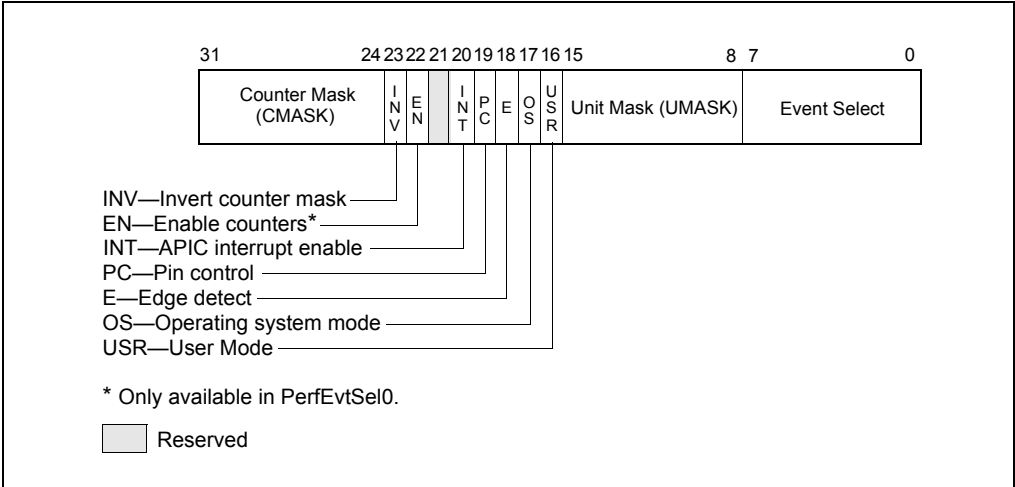


Figure 18-50. PerfEvtSel0 and PerfEvtSel1 MSRs

- **USR (user mode) flag (bit 16)** — Specifies that events are counted only when the processor is operating at privilege levels 1, 2 or 3. This flag can be used in conjunction with the OS flag.
- **OS (operating system mode) flag (bit 17)** — Specifies that events are counted only when the processor is operating at privilege level 0. This flag can be used in conjunction with the USR flag.
- **E (edge detect) flag (bit 18)** — Enables (when set) edge detection of events. The processor counts the number of deasserted to asserted transitions of any condition that can be expressed by the other fields. The mechanism is limited in that it does not permit back-to-back assertions to be distinguished. This mechanism allows software to measure not only the fraction of time spent in a particular state, but also the average length of time spent in such a state (for example, the time spent waiting for an interrupt to be serviced).
- **PC (pin control) flag (bit 19)** — When set, the processor toggles the PM*i* pins and increments the counter when performance-monitoring events occur; when clear, the processor toggles the PM*i* pins when the counter overflows. The toggling of a pin is defined as assertion of the pin for a single bus clock followed by deassertion.
- **INT (APIC interrupt enable) flag (bit 20)** — When set, the processor generates an exception through its local APIC on counter overflow.
- **EN (Enable Counters) Flag (bit 22)** — This flag is only present in the PerfEvtSel0 MSR. When set, performance counting is enabled in both performance-monitoring counters; when clear, both counters are disabled.
- **INV (invert) flag (bit 23)** — Inverts the result of the counter-mask comparison when set, so that both greater than and less than comparisons can be made.

- **Counter mask (CMASK) field (bits 24 through 31)** — When nonzero, the processor compares this mask to the number of events counted during a single cycle. If the event count is greater than or equal to this mask, the counter is incremented by one. Otherwise the counter is not incremented. This mask can be used to count events only if multiple occurrences happen per clock (for example, two or more instructions retired per clock). If the counter-mask field is 0, then the counter is incremented each cycle by the number of events that occurred that cycle.

### 18.17.2 PerfCtr0 and PerfCtr1 MSRs

The performance-counter MSRs (PerfCtr0 and PerfCtr1) contain the event or duration counts for the selected events being counted. The RDPMC instruction can be used by programs or procedures running at any privilege level and in virtual-8086 mode to read these counters. The PCE flag in control register CR4 (bit 8) allows the use of this instruction to be restricted to only programs and procedures running at privilege level 0.

The RDPMC instruction is not serializing or ordered with other instructions. Thus, it does not necessarily wait until all previous instructions have been executed before reading the counter. Similarly, subsequent instructions may begin execution before the RDPMC instruction operation is performed.

Only the operating system, executing at privilege level 0, can directly manipulate the performance counters, using the RDMSR and WRMSR instructions. A secure operating system would clear the PCE flag during system initialization to disable direct user access to the performance-monitoring counters, but provide a user-accessible programming interface that emulates the RDPMC instruction.

The WRMSR instruction cannot arbitrarily write to the performance-monitoring counter MSRs (PerfCtr0 and PerfCtr1). Instead, the lower-order 32 bits of each MSR may be written with any value, and the high-order 8 bits are sign-extended according to the value of bit 31. This operation allows writing both positive and negative values to the performance counters.

### 18.17.3 Starting and Stopping the Performance-Monitoring Counters

The performance-monitoring counters are started by writing valid setup information in the PerfEvtSel0 and/or PerfEvtSel1 MSRs and setting the enable counters flag in the PerfEvtSel0 MSR. If the setup is valid, the counters begin counting following the execution of a WRMSR instruction that sets the enable counter flag. The counters can be stopped by clearing the enable counters flag or by clearing all the bits in the PerfEvtSel0 and PerfEvtSel1 MSRs. Counter 1 alone can be stopped by clearing the PerfEvtSel1 MSR.

### 18.17.4 Event and Time-Stamp Monitoring Software

To use the performance-monitoring counters and time-stamp counter, the operating system needs to provide an event-monitoring device driver. This driver should include procedures for handling the following operations:

- Feature checking
- Initialize and start counters
- Stop counters
- Read the event counters
- Read the time-stamp counter

The event monitor feature determination procedure must check whether the current processor supports the performance-monitoring counters and time-stamp counter. This procedure compares the family and model of the processor returned by the CPUID instruction with those of processors known to support performance monitoring. (The Pentium and P6 family processors support performance counters.) The procedure also checks the MSR and TSC flags returned to register EDX by the CPUID instruction to determine if the MSRs and the RDTSC instruction are supported.

The initialize and start counters procedure sets the PerfEvtSel0 and/or PerfEvtSel1 MSRs for the events to be counted and the method used to count them and initializes the counter MSRs (PerfCtr0 and PerfCtr1) to starting counts. The stop counters procedure stops the performance counters (see Section 18.17.3, "Starting and Stopping the Performance-Monitoring Counters").

The read counters procedure reads the values in the PerfCtr0 and PerfCtr1 MSRs, and a read time-stamp counter procedure reads the time-stamp counter. These procedures would be provided in lieu of enabling the RDTSC and RDPMC instructions that allow application code to read the counters.

### 18.17.5 Monitoring Counter Overflow

The P6 family processors provide the option of generating a local APIC interrupt when a performance-monitoring counter overflows. This mechanism is enabled by setting the interrupt enable flag in either the PerfEvtSel0 or the PerfEvtSel1 MSR. The primary use of this option is for statistical performance sampling.

To use this option, the operating system should do the following things on the processor for which performance events are required to be monitored:

- Provide an interrupt vector for handling the counter-overflow interrupt.
- Initialize the APIC PERF local vector entry to enable handling of performance-monitor counter overflow events.
- Provide an entry in the IDT that points to a stub exception handler that returns without executing any instructions.
- Provide an event monitor driver that provides the actual interrupt handler and modifies the reserved IDT entry to point to its interrupt routine.

When interrupted by a counter overflow, the interrupt handler needs to perform the following actions:

- Save the instruction pointer (EIP register), code-segment selector, TSS segment selector, counter values and other relevant information at the time of the interrupt.
- Reset the counter to its initial setting and return from the interrupt.

An event monitor application utility or another application program can read the information collected for analysis of the performance of the profiled application.

## 18.18 PERFORMANCE MONITORING (PENTIUM PROCESSORS)

The Pentium processor provides two 40-bit performance counters, which can be used to count events or measure duration. The counters are supported by three MSR: the control and event select MSR (CESR) and the performance counter MSRs (CTR0 and CTR1). These can be read from and written to using the RDMSR and WRMSR instructions, respectively. They can be accessed using these instructions only when operating at privilege level 0.

Each counter has an associated external pin (PM0/BP0 and PM1/BP1), which can be used to indicate the state of the counter to external hardware.

### NOTES

The CESR, CTR0, and CTR1 MSRs and the events listed in Table 19-26 are model-specific for the Pentium processor.

The performance-monitoring events listed in Chapter 19 are intended to be used as guides for performance tuning. Counter values reported are not guaranteed to be accurate and should be used as a relative guide for tuning. Known discrepancies are documented where applicable.

### 18.18.1 Control and Event Select Register (CESR)

The 32-bit control and event select MSR (CESR) controls the operation of performance-monitoring counters CTR0 and CTR1 and the associated pins (see Figure 18-51). To control each counter, the CESR register contains a 6-bit event select field (ES0 and ES1), a pin control flag (PC0 and PC1), and a 3-bit counter control field (CC0 and CC1). The functions of these fields are as follows:

- **ES0 and ES1 (event select) fields (bits 0-5, bits 16-21)** — Selects (by entering an event code in the field) up to two events to be monitored. See Table 19-26 for a list of available event codes.



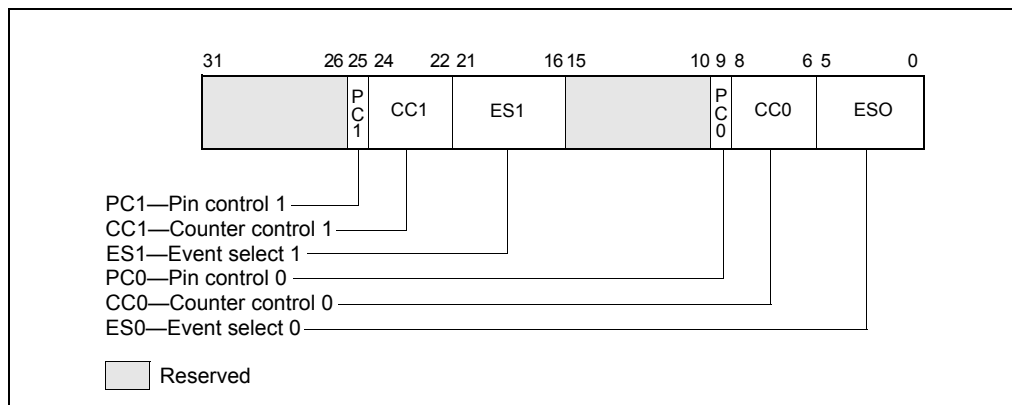


Figure 18-51. CESR MSR (Pentium Processor Only)

- CC0 and CC1 (counter control) fields (bits 6-8, bits 22-24)** — Controls the operation of the counter. Control codes are as follows:
  - 000 — Count nothing (counter disabled)
  - 001 — Count the selected event while CPL is 0, 1, or 2
  - 010 — Count the selected event while CPL is 3
  - 011 — Count the selected event regardless of CPL
  - 100 — Count nothing (counter disabled)
  - 101 — Count clocks (duration) while CPL is 0, 1, or 2
  - 110 — Count clocks (duration) while CPL is 3
  - 111 — Count clocks (duration) regardless of CPL

The highest order bit selects between counting events and counting clocks (duration); the middle bit enables counting when the CPL is 3; and the low-order bit enables counting when the CPL is 0, 1, or 2.

- PC0 and PC1 (pin control) flags (bits 9, 25)** — Selects the function of the external performance-monitoring counter pin (PM0/BP0 and PM1/BP1). Setting one of these flags to 1 causes the processor to assert its associated pin when the counter has overflowed; setting the flag to 0 causes the pin to be asserted when the counter has been incremented. These flags permit the pins to be individually programmed to indicate the overflow or incremented condition. The external signalling of the event on the pins will lag the internal event by a few clocks as the signals are latched and buffered.

While a counter need not be stopped to sample its contents, it must be stopped and cleared or preset before switching to a new event. It is not possible to set one counter separately. If only one event needs to be changed, the CESR register must

be read, the appropriate bits modified, and all bits must then be written back to CESR. At reset, all bits in the CESR register are cleared.

### 18.18.2 Use of the Performance-Monitoring Pins

When performance-monitor pins PM0/BP0 and/or PM1/BP1 are configured to indicate when the performance-monitor counter has incremented and an “occurrence event” is being counted, the associated pin is asserted (high) each time the event occurs. When a “duration event” is being counted, the associated PM pin is asserted for the entire duration of the event. When the performance-monitor pins are configured to indicate when the counter has overflowed, the associated PM pin is asserted when the counter has overflowed.

When the PM0/BP0 and/or PM1/BP1 pins are configured to signal that a counter has incremented, it should be noted that although the counters may increment by 1 or 2 in a single clock, the pins can only indicate that the event occurred. Moreover, since the internal clock frequency may be higher than the external clock frequency, a single external clock may correspond to multiple internal clocks.

A “count up to” function may be provided when the event pin is programmed to signal an overflow of the counter. Because the counters are 40 bits, a carry out of bit 39 indicates an overflow. A counter may be preset to a specific value less than  $2^{40} - 1$ . After the counter has been enabled and the prescribed number of events has transpired, the counter will overflow.

Approximately 5 clocks later, the overflow is indicated externally and appropriate action, such as signaling an interrupt, may then be taken.

The PM0/BP0 and PM1/BP1 pins also serve to indicate breakpoint matches during in-circuit emulation, during which time the counter increment or overflow function of these pins is not available. After RESET, the PM0/BP0 and PM1/BP1 pins are configured for performance monitoring, however a hardware debugger may reconfigure these pins to indicate breakpoint matches.

### 18.18.3 Events Counted

Events that performance-monitoring counters can be set to count and record (using CTR0 and CTR1) are divided in two categories: occurrence and duration:

- **Occurrence events** — Counts are incremented each time an event takes place. If PM0/BP0 or PM1/BP1 pins are used to indicate when a counter increments, the pins are asserted each clock counters increment. But if an event happens twice in one clock, the counter increments by 2 (the pins are asserted only once).
- **Duration events** — Counters increment the total number of clocks that the condition is true. When used to indicate when counters increment, PM0/BP0 and/or PM1/BP1 pins are asserted for the duration.

# CHAPTER 19

## PERFORMANCE-MONITORING EVENTS

---

This chapter lists the performance-monitoring events that can be monitored with the Intel 64 or IA-32 processors. The ability to monitor performance events and the events that can be monitored in these processors are mostly model-specific, except for architectural performance events, described in Section 19.1.

Non-architectural performance events (i.e. model-specific events) are listed for each generation of microarchitecture:

- Section 19.2 - Processors based on Intel® microarchitecture code name Ivy Bridge
- Section 19.3 - Processors based on Intel® microarchitecture code name Sandy Bridge
- Section 19.4 - Processors based on Intel® microarchitecture code name Nehalem
- Section 19.5 - Processors based on Intel® microarchitecture code name Westmere
- Section 19.6 - Processors based on Enhanced Intel® Core™ microarchitecture
- Section 19.7 - Processors based on Intel® Core™ microarchitecture
- Section 19.8 - Processors based on Intel® Atom™ microarchitecture
- Section 19.9 - Intel® Core™ Solo and Intel® Core™ Duo processors
- Section 19.10 - Processors based on Intel NetBurst® microarchitecture
- Section 19.11 - Pentium® M family processors
- Section 19.12 - P6 family processors
- Section 19.13 - Pentium® processors

### NOTE

These performance-monitoring events are intended to be used as guides for performance tuning. The counter values reported by the performance-monitoring events are approximate and believed to be useful as relative guides for tuning software. Known discrepancies are documented where applicable.

## 19.1 ARCHITECTURAL PERFORMANCE-MONITORING EVENTS

Architectural performance events are introduced in Intel Core Solo and Intel Core Duo processors. They are also supported on processors based on Intel Core microar-

chitecture. Table 19-1 lists pre-defined architectural performance events that can be configured using general-purpose performance counters and associated event-select registers.

**Table 19-1. Architectural Performance Events**

Event Num.	Event Mask Mnemonic	Umask Value	Description	Comment
3CH	UnHalted Core Cycles	00H	Unhalted core cycles	
3CH	UnHalted Reference Cycles	01H	Unhalted reference cycles	Measures bus cycle <sup>1</sup>
COH	Instruction Retired	00H	Instruction retired	
2EH	LLC Reference	4FH	Last level cache references	
2EH	LLC Misses	41H	Last level cache misses	
C4H	Branch Instruction Retired	00H	Branch instruction at retirement	
C5H	Branch Misses Retired	00H	Mispredicted Branch Instruction at retirement	

**NOTES:**

1. Implementation of this event in Intel Core 2 processor family, Intel Core Duo, and Intel Core Solo processors measures bus clocks.

## 19.2 PERFORMANCE MONITORING EVENTS FOR NEXT GENERATION INTEL® CORE™ PROCESSORS

Next generation Intel® Core™ Processors are based on the Intel microarchitecture code name Ivy Bridge. They support architectural performance-monitoring events listed in Table 19-1. Non-architectural performance-monitoring events in the processor core are listed in Table 19-2. The events in Table 19-2 apply to processors with CPUID signature of DisplayFamily\_DisplayModel encoding with the following values: 06\_3AH.

**Table 19-2. Non-Architectural Performance Events In the Processor Core of Next Generation Intel Core i7, i5, i3 Processors**

Event Num.	Umask Value	Event Mask Mnemonic	Description	Comment
03H	02H	LD_BLOCKS.STORE_FORWARD	loads blocked by overlapping with store buffer that cannot be forwarded .	
05H	01H	MISALIGN_MEM_REF.LOADS	Speculative cache-line split load uops dispatched to L1D.	

**Table 19-2. Non-Architectural Performance Events In the Processor Core of Next Generation Intel Core i7, i5, i3 Processors**

Event Num.	Umask Value	Event Mask Mnemonic	Description	Comment
05H	02H	MISALIGN_MEM_REF.STORES	Speculative cache-line split Store-address uops dispatched to L1D.	
07H	01H	LD_BLOCKS_PARTIAL.ADDRESS_ALIAS	False dependencies in MOB due to partial compare on address.	
08H	81H	DTLB_LOAD_MISSES.DEMAND_LD_MISS_CAUSES_A_WALK	Misses in all TLB levels that cause a page walk of any page size from demand loads.	
08H	82H	DTLB_LOAD_MISSES.DEMAND_LD_WALK_COMPLETED	Misses in all TLB levels that caused page walk completed of any size by demand loads.	
08H	84H	DTLB_LOAD_MISSES.DEMAND_LD_WALK_DURATION	Cycle PMH is busy with a walk due to demand loads.	
0EH	01H	UOPS_ISSUED.ANY	Increments each cycle the # of Uops issued by the RAT to RS. Set Cmask = 1, Inv = 1, Any= 1 to count stalled cycles of this core.	Set Cmask = 1, Inv = 1 to count stalled cycles
14H	01H	ARITH.FPU_DIV_ACTIVE	Cycles that the divider is active, includes INT and FP. Set 'edge = 1, cmask=1' to count the number of divides.	
24H	01H	L2_RQSTS.DEMAND_DATA_RD_HIT	Demand Data Read requests that hit L2 cache	
24H	03H	L2_RQSTS.ALL_DEMAND_DATA_RD	Counts any demand and L1 HW prefetch data load requests to L2.	
24H	04H	L2_RQSTS.RFO_HITS	Counts the number of store RFO requests that hit the L2 cache.	
24H	08H	L2_RQSTS.RFO_MISS	Counts the number of store RFO requests that miss the L2 cache.	
24H	0CH	L2_RQSTS.ALL_RFO	Counts all L2 store RFO requests.	
24H	10H	L2_RQSTS.CODE_RD_HIT	Number of instruction fetches that hit the L2 cache.	
24H	20H	L2_RQSTS.CODE_RD_MISS	Number of instruction fetches that missed the L2 cache.	
24H	30H	L2_RQSTS.ALL_CODE_RD	Counts all L2 code requests.	

**Table 19-2. Non-Architectural Performance Events In the Processor Core of Next Generation Intel Core i7, i5, i3 Processors**

Event Num.	Umask Value	Event Mask Mnemonic	Description	Comment
27H	01H	L2_STORE_LOCK_RQ STS.MISS	RFOs that miss cache lines	
27H	08H	L2_STORE_LOCK_RQ STS.HIT_M	RFOs that hit cache lines in M state	
27H	0FH	L2_STORE_LOCK_RQ STS.ALL	RFOs that access cache lines in any state	
28H	01H	L2_L1D_WB_RQSTS. MISS	Not rejected writebacks that missed LLC.	
28H	04H	L2_L1D_WB_RQSTS. HIT_E	Not rejected writebacks from L1D to L2 cache lines in E state.	
28H	08H	L2_L1D_WB_RQSTS. HIT_M	Not rejected writebacks from L1D to L2 cache lines in M state.	
2EH	4FH	LONGEST_LAT_CACH E.REFERENCE	This event counts requests originating from the core that reference a cache line in the last level cache.	see Table 19-1
2EH	41H	LONGEST_LAT_CACH E.MISS	This event counts each cache miss condition for references to the last level cache.	see Table 19-1
3CH	00H	CPU_CLK_UNHALTED .THREAD_P	Counts the number of thread cycles while the thread is not in a halt state. The thread enters the halt state when it is running the HLT instruction. The core frequency may change from time to time due to power or thermal throttling.	see Table 19-1
3CH	01H	CPU_CLK_THREAD_ UNHALTED.REF_XCL K	Increments at the frequency of XCLK (100 MHz) when not halted.	see Table 19-1
48H	01H	L1D_PEND_MISS.PE NDING	Increments the number of outstanding L1D misses every cycle. Set Cmask = 1 and Edge = 1 to count occurrences.	Counter 2 only; Set Cmask = 1 to count cycles.
49H	01H	DTLB_STORE_MISSE S.MISS_CAUSES_A_ WALK	Miss in all TLB levels causes an page walk of any page size (4K/2M/4M/1G).	

**Table 19-2. Non-Architectural Performance Events In the Processor Core of Next Generation Intel Core i7, i5, i3 Processors**

Event Num.	Umask Value	Event Mask Mnemonic	Description	Comment
49H	02H	DTLB_STORE_MISSE S.WALK_COMPLETED	Miss in all TLB levels causes a page walk that completes of any page size (4K/2M/4M/1G).	
49H	04H	DTLB_STORE_MISSE S.WALK_DURATION	Cycles PMH is busy with this walk.	
49H	10H	DTLB_STORE_MISSE S.STLB_HIT	Store operations that miss the first TLB level but hit the second and do not cause page walks	
4CH	01H	LOAD_HIT_PRE.SW_ PF	Not SW-prefetch load dispatches that hit fill buffer allocated for S/W prefetch.	
51H	01H	L1D.REPLACEMENT	Counts the number of lines brought into the L1 data cache.	
58H	01H	MOVE_ELIMINATION.I NT_NOT_ELIMINATE D	Number of integer Move Elimination candidate uops that were not eliminated.	
58H	02H	MOVE_ELIMINATION. SIMD_NOT_ELIMINAT ED	Number of SIMD Move Elimination candidate uops that were not eliminated.	
5CH	01H	CPL_CYCLES.RING0	Unhalted core cycles when the thread is in ring 0	Use Edge to count transition
5CH	02H	CPL_CYCLES.RING12 3	Unhalted core cycles when the thread is not in ring 0	
5EH	01H	RS_EVENTS.EMPTY_ CYCLES	Cycles the RS is empty for the thread.	
5FH	01H	TLB_ACCESS.LOAD_S TLB_HIT	Counts load operations that missed 1st level DTLB but hit the 2nd level.	
60H	01H	OFFCORE_REQUEST S_OUTSTANDING.DE MAND_DATA_RD	Offcore outstanding Demand Data Read transactions in SQ to uncore. Set Cmask=1 to count cycles.	
60H	04H	OFFCORE_REQUEST S_OUTSTANDING.DE MAND_RFO	Offcore outstanding RFO store transactions in SQ to uncore. Set Cmask=1 to count cycles.	
60H	08H	OFFCORE_REQUEST S_OUTSTANDING.AL L_DATA_RD	Offcore outstanding cacheable data read transactions in SQ to uncore. Set Cmask=1 to count cycles.	

**Table 19-2. Non-Architectural Performance Events In the Processor Core of Next Generation Intel Core i7, i5, i3 Processors**

Event Num.	Umask Value	Event Mask Mnemonic	Description	Comment
63H	01H	LOCK_CYCLES.SPLIT_LOCK_UC_LOCK_DURATION	Cycles in which the L1D and L2 are locked, due to a UC lock or split lock.	
63H	02H	LOCK_CYCLES.CACHE_LOCK_DURATION	Cycles in which the L1D is locked.	
79H	02H	IDQ.EMPTY	Counts cycles the IDQ is empty.	
79H	04H	IDQ.MITE_UOPS	Increment each cycle # of uops delivered to IDQ from MITE path. Set Cmask = 1 to count cycles.	Can combine Umask 04H and 20H
79H	08H	IDQ.DSB_UOPS	Increment each cycle. # of uops delivered to IDQ from DSB path. Set Cmask = 1 to count cycles.	Can combine Umask 08H and 10H
79H	30H	IDQ.MS_UOPS	Increment each cycle # of uops delivered to IDQ from MS by either DSB or MITE. Set Cmask = 1 to count cycles.	Can combine Umask 04H, 08H and 30H
80H	02H	ICACHE.MISSES	Number of Instruction Cache, Streaming Buffer and Victim Cache Misses. Includes UC accesses.	
85H	01H	ITLB_MISSES.MISS_CAUSES_A_WALK	Misses in all ITLB levels that cause page walks	
85H	02H	ITLB_MISSES.WALK_COMPLETED	Misses in all ITLB levels that cause completed page walks	
85H	04H	ITLB_MISSES.WALK_DURATION	Cycle PMH is busy with a walk.	
85H	10H	ITLB_MISSES.STLB_HIT	Number of cache load STLB hits. No page walk.	
87H	01H	ILD_STALL.LCP	Stalls caused by changing prefix length of the instruction.	
87H	04H	ILD_STALL.IQ_FULL	Stall cycles due to IQ is full.	
88H	01H	BR_INST_EXEC.COND	Qualify conditional near branch instructions executed, but not necessarily retired.	Must combine with umask 40H, 80H
88H	02H	BR_INST_EXEC.DIRECT_JMP	Qualify all unconditional near branch instructions excluding calls and indirect branches.	Must combine with umask 80H



**Table 19-2. Non-Architectural Performance Events In the Processor Core of Next Generation Intel Core i7, i5, i3 Processors**

Event Num.	Umask Value	Event Mask Mnemonic	Description	Comment
88H	04H	BR_INST_EXEC.INDIRECT_JMP_NON_CALL_RET	Qualify executed indirect near branch instructions that are not calls nor returns.	Must combine with umask 80H
88H	08H	BR_INST_EXEC.RETURN_NEAR	Qualify indirect near branches that have a return mnemonic.	Must combine with umask 80H
88H	10H	BR_INST_EXEC.DIRECT_NEAR_CALL	Qualify unconditional near call branch instructions, excluding non call branch, executed.	Must combine with umask 80H
88H	20H	BR_INST_EXEC.INDIRECT_NEAR_CALL	Qualify indirect near calls, including both register and memory indirect, executed.	Must combine with umask 80H
88H	40H	BR_INST_EXEC.NON_TAKEN	Qualify non-taken near branches executed.	Applicable to umask 01H only
88H	80H	BR_INST_EXEC.TAKEN	Qualify taken near branches executed. Must combine with 01H,02H, 04H, 08H, 10H, 20H	
88H	FFH	BR_INST_EXEC.ALL_BRANCHES	Counts all near executed branches (not necessarily retired).	
89H	01H	BR_MISP_EXEC.COND	Qualify conditional near branch instructions mispredicted.	Must combine with umask 40H, 80H
89H	04H	BR_MISP_EXEC.INDIRECT_JMP_NON_CALL_RET	Qualify mispredicted indirect near branch instructions that are not calls nor returns.	Must combine with umask 80H
89H	08H	BR_MISP_EXEC.RETURN_NEAR	Qualify mispredicted indirect near branches that have a return mnemonic.	Must combine with umask 80H
89H	10H	BR_MISP_EXEC.DIRECT_NEAR_CALL	Qualify mispredicted unconditional near call branch instructions, excluding non call branch, executed.	Must combine with umask 80H
89H	20H	BR_MISP_EXEC.INDIRECT_NEAR_CALL	Qualify mispredicted indirect near calls, including both register and memory indirect, executed.	Must combine with umask 80H
89H	40H	BR_MISP_EXEC.NON_TAKEN	Qualify mispredicted non-taken near branches executed,.	Applicable to umask 01H only
89H	80H	BR_MISP_EXEC.TAKEN	Qualify mispredicted taken near branches executed. Must combine with 01H,02H, 04H, 08H, 10H, 20H	

**Table 19-2. Non-Architectural Performance Events In the Processor Core of Next Generation Intel Core i7, i5, i3 Processors**

Event Num.	Umask Value	Event Mask Mnemonic	Description	Comment
89H	FFH	BR_MISP_EXEC.ALL_BRANCHES	Counts all near executed branches (not necessarily retired).	
9CH	01H	IDQ_UOPS_NOT_DELIVERED.CORE	Count number of non-delivered uops to RAT per thread.	Use Cmask to qualify uop b/w
A1H	01H	UOPS_DISPATCHED_PORT.PORT_0	Cycles which a Uop is dispatched on port 0.	
A1H	02H	UOPS_DISPATCHED_PORT.PORT_1	Cycles which a Uop is dispatched on port 1.	
A1H	04H	UOPS_DISPATCHED_PORT.PORT_2_LD	Cycles which a load uop is dispatched on port 2.	
A1H	08H	UOPS_DISPATCHED_PORT.PORT_2_STA	Cycles which a store address uop is dispatched on port 2.	
A1H	0CH	UOPS_DISPATCHED_PORT.PORT_2	Cycles which a Uop is dispatched on port 2.	
A1H	10H	UOPS_DISPATCHED_PORT.PORT_3_LD	Cycles which a load uop is dispatched on port 3.	
A1H	20H	UOPS_DISPATCHED_PORT.PORT_3_STA	Cycles which a store address uop is dispatched on port 3.	
A1H	30H	UOPS_DISPATCHED_PORT.PORT_3	Cycles which a Uop is dispatched on port 3.	
A1H	40H	UOPS_DISPATCHED_PORT.PORT_4	Cycles which a Uop is dispatched on port 4.	
A1H	80H	UOPS_DISPATCHED_PORT.PORT_5	Cycles which a Uop is dispatched on port 5.	
A2H	01H	RESOURCE_STALLS.ANY	Cycles Allocation is stalled due to Resource Related reason.	
A2H	04H	RESOURCE_STALLS.RS	Cycles stalled due to no eligible RS entry available.	
A2H	08H	RESOURCE_STALLS.SB	Cycles stalled due to no store buffers available. (not including draining form sync).	
A2H	10H	RESOURCE_STALLS.ROB	Cycles stalled due to re-order buffer full.	
ABH	01H	DSB2MITE_SWITCHES.COUNT	Number of DSB to MITE switches.	

**Table 19-2. Non-Architectural Performance Events In the Processor Core of Next Generation Intel Core i7, i5, i3 Processors**

Event Num.	Umask Value	Event Mask Mnemonic	Description	Comment
ABH	02H	DSB2MITE_SWITCHES.PENALTY_CYCLES	Cycles DSB to MITE switches caused delay.	
ACH	08H	DSB_FILL.EXCEED_DSB_LINES	DSB Fill encountered > 3 DSB lines.	
AEH	01H	ITLB.ITLB_FLUSH	Counts the number of ITLB flushes, includes 4k/2M/4M pages.	
BOH	01H	OFFCORE_REQUESTS.DEMAND_DATA_RD	Demand data read requests sent to uncore.	
BOH	02H	OFFCORE_REQUESTS.DEMAND_CODE_RD	Demand code read requests sent to uncore.	
BOH	04H	OFFCORE_REQUESTS.DEMAND_RFO	Demand RFO read requests sent to uncore., including regular RFOs, locks, ItoM	
BOH	08H	OFFCORE_REQUESTS.ALL_DATA_RD	Data read requests sent to uncore (demand and prefetch).	
B1H	01H	UOPS_DISPATCHED.THREAD	Counts total number of uops to be dispatched per-thread each cycle. Set Cmask = 1, INV = 1 to count stall cycles.	
B1H	02H	UOPS_DISPATCHED.CORE	Counts total number of uops to be dispatched per-core each cycle.	Do not need to set ANY
B7H	01H	OFF_CORE_RESPONSE_0	see Section 18.8.5, "Off-core Response Performance Monitoring"; PMCO only.	Requires programming MSR 01A6H
BBH	01H	OFF_CORE_RESPONSE_1	See Section 18.8.5, "Off-core Response Performance Monitoring". PMC3 only.	Requires programming MSR 01A7H
COH	00H	INST_RETIRED.ANY_P	Number of instructions at retirement	See Table 19-1
COH	01H	INST_RETIRED.PREC_DIST	Precise instruction retired event with HW to reduce effect of PEBS shadow in IP distribution	PMC1 only; Must quiesce other PMCs.
C1H	08H	OTHER_ASSISTS.AVX_STORE	Number of assists associated with 256-bit AVX store operations.	
C1H	10H	OTHER_ASSISTS.AVX_TO_SSE	Number of transitions from AVX-256 to legacy SSE when penalty applicable.	

**Table 19-2. Non-Architectural Performance Events In the Processor Core of Next Generation Intel Core i7, i5, i3 Processors**

Event Num.	Umask Value	Event Mask Mnemonic	Description	Comment
C1H	20H	OTHER_ASSISTS.SSE_TO_AVX	Number of transitions from SSE to AVX-256 when penalty applicable.	
C2H	01H	UOPS_RETIRED.ALL	Counts the number of micro-ops retired, Use cmask=1 and invert to count active cycles or stalled cycles.	Supports PEBS
C2H	02H	UOPS_RETIRED.RETIRE_SLOTS	Counts the number of retirement slots used each cycle.	
C3H	02H	MACHINE_CLEARS.MEMORY_ORDERING	Counts the number of machine clears due to memory order conflicts.	
C3H	20H	MACHINE_CLEARS.MASKMOV	Counts the number of executed AVX masked load operations that refer to an illegal address range with the mask bits set to 0.	
C4H	00H	BR_INST_RETIRED.ALL_BRANCHES	Branch instructions at retirement	See Table 19-1
C4H	01H	BR_INST_RETIRED.CONDITIONAL	Counts the number of conditional branch instructions retired.	Supports PEBS
C4H	02H	BR_INST_RETIRED.NEAR_CALL	Direct and indirect near call instructions retired.	
C4H	04H	BR_INST_RETIRED.ALL_BRANCHES	Counts the number of branch instructions retired.	
C4H	08H	BR_INST_RETIRED.NEAR_RETURN	Counts the number of near return instructions retired.	
C4H	10H	BR_INST_RETIRED.NOT_TAKEN	Counts the number of not taken branch instructions retired.	
C4H	20H	BR_INST_RETIRED.NEAR_TAKEN	Number of near taken branches retired.	
C4H	40H	BR_INST_RETIRED.FAR_BRANCH	Number of far branches retired.	
C5H	00H	BR_MISP_RETIRED.ALL_BRANCHES	Mispredicted branch instructions at retirement	See Table 19-1
C5H	01H	BR_MISP_RETIRED.CONDITIONAL	Mispredicted conditional branch instructions retired.	Supports PEBS
C5H	02H	BR_MISP_RETIRED.NEAR_CALL	Direct and indirect mispredicted near call instructions retired.	

**Table 19-2. Non-Architectural Performance Events In the Processor Core of Next Generation Intel Core i7, i5, i3 Processors**

Event Num.	Umask Value	Event Mask Mnemonic	Description	Comment
C5H	04H	BR_MISP_RETIRED.ALL_BRANCHES	Mispredicted macro branch instructions retired.	
C5H	10H	BR_MISP_RETIRED.NOT_TAKEN	Mispredicted not taken branch instructions retired.	
C5H	20H	BR_MISP_RETIRED.TAKEN	Mispredicted taken branch instructions retired.	
CAH	08H	FP_ASSIST.SIMD_OUTPUT	Number of SIMD FP assists due to Output values	
CAH	10H	FP_ASSIST.SIMD_INPUT	Number of SIMD FP assists due to input values	
CAH	1EH	FP_ASSIST.ANY	Cycles with any input/output SSE* or FP assists	
CCH	20H	ROB_MISC_EVENTS.LBR_INSERTS	Count cases of saving new LBR records by hardware.	
CDH	01H	MEM_TRANS_RETIRED.LOAD_LATENCY	Sample loads with specified latency threshold. PMC3 only.	Specify threshold in MSR 0x3F6
CDH	02H	MEM_TRANS_RETIRED.PRECISE_STORE	Sample stores and collect precise store operation via PEBS record. PMC3 only.	See Section 18.8.4.3
DOH	01H	MEM_UOP_RETIRED.LOADS	Qualify retired memory uops that are loads. Combine with umask 10H, 20H, 40H, 80H.	Supports PEBS
DOH	02H	MEM_UOP_RETIRED.STORES	Qualify retired memory uops that are stores. Combine with umask 10H, 20H, 40H, 80H.	
DOH	10H	MEM_UOP_RETIRED.STLB_MISS	Qualify retired memory uops with STLB miss. Must combine with umask 01H, 02H, to produce counts.	
DOH	20H	MEM_UOP_RETIRED.LOCK	Qualify retired memory uops with lock. Must combine with umask 01H, 02H, to produce counts.	
DOH	40H	MEM_UOP_RETIRED.SPLIT	Qualify retired memory uops with line split. Must combine with umask 01H, 02H, to produce counts.	
DOH	80H	MEM_UOP_RETIRED.ALL	Qualify any retired memory uops. Must combine with umask 01H, 02H, to produce counts.	

**Table 19-2. Non-Architectural Performance Events In the Processor Core of Next Generation Intel Core i7, i5, i3 Processors**

Event Num.	Umask Value	Event Mask Mnemonic	Description	Comment
D1H	01H	MEM_LOAD_UOPS_RETIREDL1_HIT	Retired load uops with L1 cache hits as data sources.	Supports PEBS
D1H	02H	MEM_LOAD_UOPS_RETIREDL2_HIT	Retired load uops with L2 cache hits as data sources.	
D1H	04H	MEM_LOAD_UOPS_RETIREDLLC_HIT	Retired load uops with LLC cache hits as data sources.	
D1H	40H	MEM_LOAD_UOPS_RETIREDL1_HIT_LFB	Retired load uops which data sources were load uops missed L1 but hit FB due to preceding miss to the same cache line with data not ready.	
D2H	02H	MEM_LOAD_UOPS_LLC_HIT_RETIREDXSNP_HIT	Retired load uops which data sources were LLC and cross-core snoop hits in on-pkg core cache.	Supports PEBS
D2H	04H	MEM_LOAD_UOPS_LLC_HIT_RETIREDXSNP_HITM	Retired load uops which data sources were HitM responses from shared LLC.	
D2H	08H	MEM_LOAD_UOPS_LLC_HIT_RETIREDXSNP_NONE	Retired load uops which data sources were hits in LLC without snoops required.	
D3H	01H	MEM_LOAD_UOPS_LLC_MISS_RETIREDL0CAL_DRAM	Retired load uops which data sources missed LLC but serviced from local dram.	Supports PEBS.
FOH	01H	L2_TRANS.DEMAND_DATA_RD	Demand Data Read requests that access L2 cache	
FOH	02H	L2_TRANS.RFO	RFO requests that access L2 cache	
FOH	04H	L2_TRANS.CODE_RD	L2 cache accesses when fetching instructions	
FOH	10H	L2_TRANS.L1D_WB	L1D writebacks that access L2 cache	
FOH	20H	L2_TRANS.L2_FILL	L2 fill requests that access L2 cache	
FOH	40H	L2_TRANS.L2_WB	L2 writebacks that access L2 cache	
FOH	80H	L2_TRANS.ALL_REQUESTS	Transactions accessing L2 pipe	
F1H	01H	L2_LINES_IN_I	L2 cache lines in I state filling L2	Counting does not cover rejects.

**Table 19-2. Non-Architectural Performance Events In the Processor Core of Next Generation Intel Core i7, i5, i3 Processors**

Event Num.	Umask Value	Event Mask Mnemonic	Description	Comment
F1H	02H	L2_LINES_IN.S	L2 cache lines in S state filling L2	Counting does not cover rejects.
F1H	04H	L2_LINES_IN.E	L2 cache lines in E state filling L2	Counting does not cover rejects.
F1H	07H	L2_LINES_IN.ALL	L2 cache lines filling L2	Counting does not cover rejects.
F2H	01H	L2_LINES_OUT.DEMAND_CLEAN	Clean L2 cache lines evicted by demand	
F2H	02H	L2_LINES_OUT.DEMAND_DIRTY	Dirty L2 cache lines evicted by demand	
F2H	0AH	L2_LINES_OUT.DIRTY_ALL	Dirty L2 cache lines filling the L2	Counting does not cover rejects.

### 19.3 PERFORMANCE MONITORING EVENTS FOR 2ND GENERATION INTEL® CORE™ I7-2XXX, INTEL® CORE™ I5-2XXX, INTEL® CORE™ I3-2XXX PROCESSOR SERIES

Second generation Intel® Core™ i7-2xxx, Intel® Core™ i5-2xxx, Intel® Core™ i3-2xxx processor series are based on the Intel microarchitecture code name Sandy Bridge. They support architectural performance-monitoring events listed in Table 19-1. Non-architectural performance-monitoring events in the processor core are listed in Table 19-3, Table 19-4, and Table 19-5. The events in Table 19-3 apply to processors with CPUID signature of DisplayFamily\_DisplayModel encoding with the following values: 06\_2AH and 06\_2DH. The events in Table 19-4 apply to processors with CPUID signature 06\_2AH. The events in Table 19-5 apply to processors with CPUID signature 06\_2DH.

**Table 19-3. Non-Architectural Performance Events In the Processor Core Common to 2nd Generation Intel® Core™ i7-2xxx, Intel® Core™ i5-2xxx, Intel® Core™ i3-2xxx Processor Series and Intel® Xeon® Processors E5 Family**

Event Num.	Umask Value	Event Mask Mnemonic	Description	Comment
03H	01H	LD_BLOCKS.DATA_U NKNOWN	blocked loads due to store buffer blocks with unknown data.	
03H	02H	LD_BLOCKS.STORE_F ORWARD	loads blocked by overlapping with store buffer that cannot be forwarded .	
03H	08H	LD_BLOCKS.NO_SR	# of Split loads blocked due to resource not available.	
03H	10H	LD_BLOCKS.ALL_BLO CK	Number of cases where any load is blocked but has no DCU miss.	
05H	01H	MISALIGN_MEM_REF. LOADS	Speculative cache-line split load uops dispatched to L1D.	
05H	02H	MISALIGN_MEM_REF. STORES	Speculative cache-line split Store-address uops dispatched to L1D.	
07H	01H	LD_BLOCKS_PARTIA L.ADDRESS_ALIAS	False dependencies in MOB due to partial compare on address.	
07H	08H	LD_BLOCKS_PARTIA L.ALL_STA_BLOCK	The number of times that load operations are temporarily blocked because of older stores, with addresses that are not yet known. A load operation may incur more than one block of this type.	
08H	01H	DTLB_LOAD_MISSES. MISS_CAUSES_A_WA LK	Misses in all TLB levels that cause a page walk of any page size.	
08H	02H	DTLB_LOAD_MISSES. WALK_COMPLETED	Misses in all TLB levels that caused page walk completed of any size.	
08H	04H	DTLB_LOAD_MISSES. WALK_DURATION	Cycle PMH is busy with a walk.	
08H	10H	DTLB_LOAD_MISSES. STLB_HIT	Number of cache load STLB hits. No page walk.	
0DH	03H	INT_MISC.RECOVERY _CYCLES	Cycles waiting to recover after Machine Clears or JEClear. Set Cmask= 1.	Set Edge to count occurrences
0DH	40H	INT_MISC.RAT_STALL _CYCLES	Cycles RAT external stall is sent to IDQ for this thread.	



**Table 19-3. Non-Architectural Performance Events In the Processor Core Common to 2nd Generation Intel® Core™ i7-2xxx, Intel® Core™ i5-2xxx, Intel® Core™ i3-2xxx Processor Series and Intel® Xeon® Processors E5 Family**

Event Num.	Umask Value	Event Mask Mnemonic	Description	Comment
0EH	01H	UOPS_ISSUED.ANY	Increments each cycle the # of Uops issued by the RAT to RS. Set Cmask = 1, Inv = 1, Any= 1 to count stalled cycles of this core.	Set Cmask = 1, Inv = 1 to count stalled cycles
10H	01H	FP_COMP_OPS_EXE.X87	Counts number of X87 uops executed.	
10H	10H	FP_COMP_OPS_EXE.SSE_FP_PACKED_DOUBLE	Counts number of SSE* double precision FP packed uops executed.	
10H	20H	FP_COMP_OPS_EXE.SSE_FP_SCALAR_SINGLE	Counts number of SSE* single precision FP scalar uops executed.	
10H	40H	FP_COMP_OPS_EXE.SSE_PACKED_SINGLE	Counts number of SSE* single precision FP packed uops executed.	
10H	80H	FP_COMP_OPS_EXE.SSE_SCALAR_DOUBLE	Counts number of SSE* double precision FP scalar uops executed.	
11H	01H	SIMD_FP_256.PACKED_SINGLE	Counts 256-bit packed single-precision floating-point instructions	
11H	02H	SIMD_FP_256.PACKED_DOUBLE	Counts 256-bit packed double-precision floating-point instructions	
14H	01H	ARITH.FPU_DIV_ACTIVE	Cycles that the divider is active, includes INT and FP. Set 'edge =1, cmask='1' to count the number of divides.	
17H	01H	INSTS_WRITTEN_TO_IQ.INSTS	Counts the number of instructions written into the IQ every cycle.	
24H	01H	L2_RQSTS.DEMAND_DATA_RD_HIT	Demand Data Read requests that hit L2 cache	
24H	03H	L2_RQSTS.ALL_DEMAND_DATA_RD	Counts any demand and L1 HW prefetch data load requests to L2.	
24H	04H	L2_RQSTS.RFO_HITS	Counts the number of store RFO requests that hit the L2 cache.	
24H	08H	L2_RQSTS.RFO_MISS	Counts the number of store RFO requests that miss the L2 cache.	
24H	0CH	L2_RQSTS.ALL_RFO	Counts all L2 store RFO requests.	

**Table 19-3. Non-Architectural Performance Events In the Processor Core Common to 2nd Generation Intel® Core™ i7-2xxx, Intel® Core™ i5-2xxx, Intel® Core™ i3-2xxx Processor Series and Intel® Xeon® Processors E5 Family**

Event Num.	Umask Value	Event Mask Mnemonic	Description	Comment
24H	10H	L2_RQSTS.CODE_RD_HIT	Number of instruction fetches that hit the L2 cache.	
24H	20H	L2_RQSTS.CODE_RD_MISS	Number of instruction fetches that missed the L2 cache.	
24H	30H	L2_RQSTS.ALL_CODE_RD	Counts all L2 code requests.	
24H	40H	L2_RQSTS.PF_HIT	Requests from L2 Hardware prefetcher that hit L2.	
24H	80H	L2_RQSTS.PF_MISS	Requests from L2 Hardware prefetcher that missed L2.	
24H	C0H	L2_RQSTS.ALL_PF	Any requests from L2 Hardware prefetchers	
27H	01H	L2_STORE_LOCK_RQSTS.MISS	RFOs that miss cache lines	
27H	04H	L2_STORE_LOCK_RQSTS.HIT_E	RFOs that hit cache lines in E state	
27H	08H	L2_STORE_LOCK_RQSTS.HIT_M	RFOs that hit cache lines in M state	
27H	0FH	L2_STORE_LOCK_RQSTS.ALL	RFOs that access cache lines in any state	
28H	04H	L2_L1D_WB_RQSTS.HIT_E	Not rejected writebacks from L1D to L2 cache lines in E state.	
28H	08H	L2_L1D_WB_RQSTS.HIT_M	Not rejected writebacks from L1D to L2 cache lines in M state.	
2EH	4FH	LONGEST_LAT_CACHE.REFERENCE	This event counts requests originating from the core that reference a cache line in the last level cache.	see Table 19-1
2EH	41H	LONGEST_LAT_CACHE.MISS	This event counts each cache miss condition for references to the last level cache.	see Table 19-1

**Table 19-3. Non-Architectural Performance Events In the Processor Core Common to 2nd Generation Intel® Core™ i7-2xxx, Intel® Core™ i5-2xxx, Intel® Core™ i3-2xxx Processor Series and Intel® Xeon® Processors E5 Family**

Event Num.	Umask Value	Event Mask Mnemonic	Description	Comment
3CH	00H	CPU_CLK_UNHALTED.THREAD_P	Counts the number of thread cycles while the thread is not in a halt state. The thread enters the halt state when it is running the HLT instruction. The core frequency may change from time to time due to power or thermal throttling.	see Table 19-1
3CH	01H	CPU_CLK_THREAD_UNHALTED.REF_XCLK	Increments at the frequency of XCLK (100 MHz) when not halted.	see Table 19-1
48H	01H	L1D_PEND_MISS.PENDING	Increments the number of outstanding L1D misses every cycle. Set Cmaks = 1 and Edge = 1 to count occurrences.	Counter 2 only; Set Cmask = 1 to count cycles.
49H	01H	DTLB_STORE_MISSES.MISS_CAUSES_A_WALK	Miss in all TLB levels causes a page walk of any page size (4K/2M/4M/1G).	
49H	02H	DTLB_STORE_MISSES.WALK_COMPLETED	Miss in all TLB levels causes a page walk that completes of any page size (4K/2M/4M/1G).	
49H	04H	DTLB_STORE_MISSES.WALK_DURATION	Cycles PMH is busy with this walk.	
49H	10H	DTLB_STORE_MISSES.STLB_HIT	Store operations that miss the first TLB level but hit the second and do not cause page walks	
4CH	01H	LOAD_HIT_PRE.SW_PF	Not SW-prefetch load dispatches that hit fill buffer allocated for S/W prefetch.	
4CH	02H	LOAD_HIT_PRE.HW_PF	Not SW-prefetch load dispatches that hit fill buffer allocated for H/W prefetch.	
4EH	02H	HW_PRE_REQ.DL1_MISS	Hardware Prefetch requests that miss the L1D cache. A request is being counted each time it access the cache & miss it, including if a block is applicable or if hit the Fill Buffer for example.	This accounts for both L1 streamer and IP-based (IPP) HW prefetchers.
51H	01H	L1D.REPLACEMENT	Counts the number of lines brought into the L1 data cache.	

**Table 19-3. Non-Architectural Performance Events In the Processor Core Common to 2nd Generation Intel® Core™ i7-2xxx, Intel® Core™ i5-2xxx, Intel® Core™ i3-2xxx Processor Series and Intel® Xeon® Processors E5 Family**

Event Num.	Umask Value	Event Mask Mnemonic	Description	Comment
51H	02H	L1D.ALLOCATED_IN_M	Counts the number of allocations of modified L1D cache lines.	
51H	04H	L1D.EVICTION	Counts the number of modified lines evicted from the L1 data cache due to replacement.	
51H	08H	L1D.ALL_M_REPLACEMENT	Cache lines in M state evicted out of L1D due to Snoop HitM or dirty line replacement	
59H	20H	PARTIAL_RAT_STALLS.FLAGS_MERGE_UOP	Increments the number of flags-merge uops in flight each cycle. Set Cmask = 1 to count cycles.	
59H	40H	PARTIAL_RAT_STALLS.SLOW_LEA_WINDOW	Cycles with at least one slow LEA uop allocated.	
59H	80H	PARTIAL_RAT_STALLS.MUL_SINGLE_UOP	Number of Multiply packed/scalar single precision uops allocated.	
5BH	0CH	RESOURCE_STALLS2.ALL_FL_EMPTY	Cycles stalled due to free list empty	
5BH	0FH	RESOURCE_STALLS2.ALL_PRF_CONTROL	Cycles stalled due to control structures full for physical registers	
5BH	40H	RESOURCE_STALLS2.BOB_FULL	Cycles Allocator is stalled due Branch Order Buffer.	
5BH	4FH	RESOURCE_STALLS2.OOO_RSRC	Cycles stalled due to out of order resources full	
5CH	01H	CPL_CYCLES.RING0	Unhalted core cycles when the thread is in ring 0	Use Edge to count transition
5CH	02H	CPL_CYCLES.RING123	Unhalted core cycles when the thread is not in ring 0	
5EH	01H	RS_EVENTS.EMPTY_CYCLES	Cycles the RS is empty for the thread.	
60H	01H	OFFCORE_REQUESTS_OUTSTANDING.DEMAND_DATA_RD	Offcore outstanding Demand Data Read transactions in SQ to uncore. Set Cmask=1 to count cycles.	
60H	04H	OFFCORE_REQUESTS_OUTSTANDING.DEMAND_RFO	Offcore outstanding RFO store transactions in SQ to uncore. Set Cmask=1 to count cycles.	

**Table 19-3. Non-Architectural Performance Events In the Processor Core Common to 2nd Generation Intel® Core™ i7-2xxx, Intel® Core™ i5-2xxx, Intel® Core™ i3-2xxx Processor Series and Intel® Xeon® Processors E5 Family**

Event Num.	Umask Value	Event Mask Mnemonic	Description	Comment
60H	08H	OFFCORE_REQUEST_S_OUTSTANDING.AL_L_DATA_RD	Offcore outstanding cacheable data read transactions in SQ to uncore. Set Cmask=1 to count cycles.	
63H	01H	LOCK_CYCLES.SPLIT_LOCK_UC_LOCK_DURATION	Cycles in which the L1D and L2 are locked, due to a UC lock or split lock.	
63H	02H	LOCK_CYCLES.CACHE_LOCK_DURATION	Cycles in which the L1D is locked.	
79H	02H	IDQ.EMPTY	Counts cycles the IDQ is empty.	
79H	04H	IDQ.MITE_UOPS	Increment each cycle # of uops delivered to IDQ from MITE path. Set Cmask = 1 to count cycles.	Can combine Umask 04H and 20H
79H	08H	IDQ.DSB_UOPS	Increment each cycle. # of uops delivered to IDQ from DSB path. Set Cmask = 1 to count cycles.	Can combine Umask 08H and 10H
79H	10H	IDQ.MS_DSB_UOPS	Increment each cycle # of uops delivered to IDQ when MS busy by DSB. Set Cmask = 1 to count cycles MS is busy. Set Cmask=1 and Edge =1 to count MS activations.	Can combine Umask 08H and 10H
79H	20H	IDQ.MS_MITE_UOPS	Increment each cycle # of uops delivered to IDQ when MS is busy by MITE. Set Cmask = 1 to count cycles.	Can combine Umask 04H and 20H
79H	30H	IDQ.MS_UOPS	Increment each cycle # of uops delivered to IDQ from MS by either DSB or MITE. Set Cmask = 1 to count cycles.	Can combine Umask 04H, 08H and 30H
80H	02H	ICACHE.MISSES	Number of Instruction Cache, Streaming Buffer and Victim Cache Misses. Includes UC accesses.	
85H	01H	ITLB_MISSES.MISS_CAUSES_A_WALK	Misses in all ITLB levels that cause page walks	
85H	02H	ITLB_MISSES.WALK_COMPLETED	Misses in all ITLB levels that cause completed page walks	
85H	04H	ITLB_MISSES.WALK_DURATION	Cycle PMH is busy with a walk.	

**Table 19-3. Non-Architectural Performance Events In the Processor Core Common to 2nd Generation Intel® Core™ i7-2xxx, Intel® Core™ i5-2xxx, Intel® Core™ i3-2xxx Processor Series and Intel® Xeon® Processors E5 Family**

Event Num.	Umask Value	Event Mask Mnemonic	Description	Comment
85H	10H	ITLB_MISSES.STLB_HIT	Number of cache load STLB hits. No page walk.	
87H	01H	ILD_STALL.LCP	Stalls caused by changing prefix length of the instruction.	
87H	04H	ILD_STALL.IQ_FULL	Stall cycles due to IQ is full.	
88H	01H	BR_INST_EXEC.COND	Qualify conditional near branch instructions executed, but not necessarily retired.	Must combine with umask 40H, 80H
88H	02H	BR_INST_EXEC.DIRECT_JMP	Qualify all unconditional near branch instructions excluding calls and indirect branches.	Must combine with umask 80H
88H	04H	BR_INST_EXEC.INDIRECT_JMP_NON_CALL_RET	Qualify executed indirect near branch instructions that are not calls nor returns.	Must combine with umask 80H
88H	08H	BR_INST_EXEC.RETURN_NEAR	Qualify indirect near branches that have a return mnemonic.	Must combine with umask 80H
88H	10H	BR_INST_EXEC.DIRECT_NEAR_CALL	Qualify unconditional near call branch instructions, excluding non call branch, executed.	Must combine with umask 80H
88H	20H	BR_INST_EXEC.INDIRECT_NEAR_CALL	Qualify indirect near calls, including both register and memory indirect, executed.	Must combine with umask 80H
88H	40H	BR_INST_EXEC.NON_TAKEN	Qualify non-taken near branches executed.	Applicable to umask 01H only
88H	80H	BR_INST_EXEC.TAKEN	Qualify taken near branches executed. Must combine with 01H,02H, 04H, 08H, 10H, 20H	
88H	FFH	BR_INST_EXEC.ALL_BRANCHES	Counts all near executed branches (not necessarily retired).	
89H	01H	BR_MISP_EXEC.COND	Qualify conditional near branch instructions mispredicted.	Must combine with umask 40H, 80H
89H	04H	BR_MISP_EXEC.INDIRECT_JMP_NON_CALL_RET	Qualify mispredicted indirect near branch instructions that are not calls nor returns.	Must combine with umask 80H

**Table 19-3. Non-Architectural Performance Events In the Processor Core Common to 2nd Generation Intel® Core™ i7-2xxx, Intel® Core™ i5-2xxx, Intel® Core™ i3-2xxx Processor Series and Intel® Xeon® Processors E5 Family**

Event Num.	Umask Value	Event Mask Mnemonic	Description	Comment
89H	08H	BR_MISP_EXEC.RETURN_NEAR	Qualify mispredicted indirect near branches that have a return mnemonic.	Must combine with umask 80H
89H	10H	BR_MISP_EXEC.DIRECT_NEAR_CALL	Qualify mispredicted unconditional near call branch instructions, excluding non call branch, executed.	Must combine with umask 80H
89H	20H	BR_MISP_EXEC.INDIRECT_NEAR_CALL	Qualify mispredicted indirect near calls, including both register and memory indirect, executed.	Must combine with umask 80H
89H	40H	BR_MISP_EXEC.NON_TAKEN	Qualify mispredicted non-taken near branches executed,.	Applicable to umask 01H only
89H	80H	BR_MISP_EXEC.TAKEN	Qualify mispredicted taken near branches executed. Must combine with 01H,02H, 04H, 08H, 10H, 20H	
89H	FFH	BR_MISP_EXEC.ALL_BRANCHES	Counts all near executed branches (not necessarily retired).	
9CH	01H	IDQ_UOPS_NOT_DELIVERED.CORE	Count number of non-delivered uops to RAT per thread.	Use Cmask to qualify uop b/w
A1H	01H	UOPS_DISPATCHED_PORT.PORT_0	Cycles which a Uop is dispatched on port 0.	
A1H	02H	UOPS_DISPATCHED_PORT.PORT_1	Cycles which a Uop is dispatched on port 1.	
A1H	04H	UOPS_DISPATCHED_PORT.PORT_2_LD	Cycles which a load uop is dispatched on port 2.	
A1H	08H	UOPS_DISPATCHED_PORT.PORT_2_STA	Cycles which a store address uop is dispatched on port 2.	
A1H	0CH	UOPS_DISPATCHED_PORT.PORT_2	Cycles which a Uop is dispatched on port 2.	
A1H	10H	UOPS_DISPATCHED_PORT.PORT_3_LD	Cycles which a load uop is dispatched on port 3.	
A1H	20H	UOPS_DISPATCHED_PORT.PORT_3_STA	Cycles which a store address uop is dispatched on port 3.	
A1H	30H	UOPS_DISPATCHED_PORT.PORT_3	Cycles which a Uop is dispatched on port 3.	
A1H	40H	UOPS_DISPATCHED_PORT.PORT_4	Cycles which a Uop is dispatched on port 4.	

**Table 19-3. Non-Architectural Performance Events In the Processor Core Common to 2nd Generation Intel® Core™ i7-2xxx, Intel® Core™ i5-2xxx, Intel® Core™ i3-2xxx Processor Series and Intel® Xeon® Processors E5 Family**

Event Num.	Umask Value	Event Mask Mnemonic	Description	Comment
A1H	80H	UOPS_DISPATCHED_PORT.PORT_5	Cycles which a Uop is dispatched on port 5.	
A2H	01H	RESOURCE_STALLS.ANY	Cycles Allocation is stalled due to Resource Related reason.	
A2H	02H	RESOURCE_STALLS.LB	Counts the cycles of stall due to lack of load buffers.	
A2H	04H	RESOURCE_STALLS.RS	Cycles stalled due to no eligible RS entry available.	
A2H	08H	RESOURCE_STALLS.SB	Cycles stalled due to no store buffers available. (not including draining form sync).	
A2H	10H	RESOURCE_STALLS.ROB	Cycles stalled due to re-order buffer full.	
A2H	20H	RESOURCE_STALLS.FCSW	Cycles stalled due to writing the FPU control word.	
A2H	40H	RESOURCE_STALLS.MXCSR	Cycles stalled due to the MXCSR register rename occurring to close to a previous MXCSR rename.	
A2H	80H	RESOURCE_STALLS.OTHER	Cycles stalled while execution was stalled due to other resource issues.	
ABH	01H	DSB2MITE_SWITCHES.COUNT	Number of DSB to MITE switches.	
ABH	02H	DSB2MITE_SWITCHES.PENALTY_CYCLES	Cycles DSB to MITE switches caused delay.	
ACH	02H	DSB_FILL.OTHER_CANCEL	Cases of cancelling valid DSB fill not because of exceeding way limit	
ACH	08H	DSB_FILL.EXCEED_DSB_LINES	DSB Fill encountered > 3 DSB lines.	
ACH	0AH	DSB_FILL.ALL_CANCEL	Cases of cancelling valid Decode Stream Buffer (DSB) fill not because of exceeding way limit	
AEH	01H	ITLB.ITLB_FLUSH	Counts the number of ITLB flushes, includes 4k/2M/4M pages.	
BOH	01H	OFFCORE_REQUESTS.DEMAND_DATA_RD	Demand data read requests sent to uncore.	



**Table 19-3. Non-Architectural Performance Events In the Processor Core Common to 2nd Generation Intel® Core™ i7-2xxx, Intel® Core™ i5-2xxx, Intel® Core™ i3-2xxx Processor Series and Intel® Xeon® Processors E5 Family**

Event Num.	Umask Value	Event Mask Mnemonic	Description	Comment
BOH	04H	OFFCORE_REQUEST S.DEMAND_RFO	Demand RFO read requests sent to uncore., including regular RFOs, locks, ItoM	
BOH	08H	OFFCORE_REQUEST S.ALL_DATA_RD	Data read requests sent to uncore (demand and prefetch).	
B1H	01H	UOPS_DISPATCHED.T HREAD	Counts total number of uops to be dispatched per-thread each cycle. Set Cmask = 1, INV =1 to count stall cycles.	
B1H	02H	UOPS_DISPATCHED.C ORE	Counts total number of uops to be dispatched per-core each cycle.	Do not need to set ANY
B2H	01H	OFFCORE_REQUEST S_BUFFER.SQ_FULL	Offcore requests buffer cannot take more entries for this thread core.	
B6H	01H	AGU_BYPASS_CANCE L.COUNT	Counts executed load operations with all the following traits: 1. addressing of the format [base + offset], 2. the offset is between 1 and 2047, 3. the address specified in the base register is in one page and the address [base+offset] is in another page.	
B7H	01H	OFF_CORE_RESPONS E_0	see Section 18.8.5, "Off-core Response Performance Monitoring"; PMCO only.	Requires programming MSR 01A6H
BBH	01H	OFF_CORE_RESPONS E_1	See Section 18.8.5, "Off-core Response Performance Monitoring". PMC3 only.	Requires programming MSR 01A7H
BDH	01H	TLB_FLUSH.DTLB_T HREAD	DTLB flush attempts of the thread-specific entries	
BDH	20H	TLB_FLUSH.STLB_A NY	Count number of STLB flush attempts	
BFH	05H	L1D_BLOCKS.BANK_ CONFLICT_CYCLES	Cycles when dispatched loads are cancelled due to L1D bank conflicts with other load ports	cmask=1
COH	00H	INST_RETIRED.ANY_ P	Number of instructions at retirement	See Table 19-1

**Table 19-3. Non-Architectural Performance Events In the Processor Core Common to 2nd Generation Intel® Core™ i7-2xxx, Intel® Core™ i5-2xxx, Intel® Core™ i3-2xxx Processor Series and Intel® Xeon® Processors E5 Family**

Event Num.	Umask Value	Event Mask Mnemonic	Description	Comment
C0H	01H	INST_RETIRED.PREC_DIST	Precise instruction retired event with HW to reduce effect of PEBS shadow in IP distribution	PMC1 only; Must quiesce other PMCs.
C1H	02H	OTHER_ASSISTS.ITLB_MISS_RETIRED	Instructions that experienced an ITLB miss.	
C1H	08H	OTHER_ASSISTS.AVX_STORE	Number of assists associated with 256-bit AVX store operations.	
C1H	10H	OTHER_ASSISTS.AVX_TO_SSE	Number of transitions from AVX-256 to legacy SSE when penalty applicable.	
C1H	20H	OTHER_ASSISTS.SSE_TO_AVX	Number of transitions from SSE to AVX-256 when penalty applicable.	
C2H	01H	UOPS_RETIRED.ALL	Counts the number of micro-ops retired, Use cmask=1 and invert to count active cycles or stalled cycles.	Supports PEBS
C2H	02H	UOPS_RETIRED.RETIRE_SLOTS	Counts the number of retirement slots used each cycle.	
C3H	02H	MACHINE_CLEARS.MEMORY_ORDERING	Counts the number of machine clears due to memory order conflicts.	
C3H	04H	MACHINE_CLEARS.SMC	Counts the number of times that a program writes to a code section.	
C3H	20H	MACHINE_CLEARS.MASKMOV	Counts the number of executed AVX masked load operations that refer to an illegal address range with the mask bits set to 0.	
C4H	00H	BR_INST_RETIRED.ALL_BRANCHES	Branch instructions at retirement	See Table 19-1
C4H	01H	BR_INST_RETIRED.CONDITIONAL	Counts the number of conditional branch instructions retired.	Supports PEBS
C4H	02H	BR_INST_RETIRED.NEAR_CALL	Direct and indirect near call instructions retired.	
C4H	04H	BR_INST_RETIRED.ALL_BRANCHES	Counts the number of branch instructions retired.	
C4H	08H	BR_INST_RETIRED.NEAR_RETURN	Counts the number of near return instructions retired.	

**Table 19-3. Non-Architectural Performance Events In the Processor Core Common to 2nd Generation Intel® Core™ i7-2xxx, Intel® Core™ i5-2xxx, Intel® Core™ i3-2xxx Processor Series and Intel® Xeon® Processors E5 Family**

Event Num.	Umask Value	Event Mask Mnemonic	Description	Comment
C4H	10H	BR_INST_RETIRED.NOT_TAKEN	Counts the number of not taken branch instructions retired.	
C4H	20H	BR_INST_RETIRED.NEAR_TAKEN	Number of near taken branches retired.	
C4H	40H	BR_INST_RETIRED.FAR_BRANCH	Number of far branches retired.	
C5H	00H	BR_MISP_RETIRED.ALL_BRANCHES	Mispredicted branch instructions at retirement	See Table 19-1
C5H	01H	BR_MISP_RETIRED.CONDITIONAL	Mispredicted conditional branch instructions retired.	Supports PEBS
C5H	02H	BR_MISP_RETIRED.NEAR_CALL	Direct and indirect mispredicted near call instructions retired.	
C5H	04H	BR_MISP_RETIRED.ALL_BRANCHES	Mispredicted macro branch instructions retired.	
C5H	10H	BR_MISP_RETIRED.NOT_TAKEN	Mispredicted not taken branch instructions retired.	
C5H	20H	BR_MISP_RETIRED.TAKEN	Mispredicted taken branch instructions retired.	
CAH	02H	FP_ASSIST.X87_OUTPUT	Number of X87 assists due to output value.	
CAH	04H	FP_ASSIST.X87_INPUT	Number of X87 assists due to input value.	
CAH	08H	FP_ASSIST.SIMD_OUTPUT	Number of SIMD FP assists due to Output values	
CAH	10H	FP_ASSIST.SIMD_INPUT	Number of SIMD FP assists due to input values	
CAH	1EH	FP_ASSIST.ANY	Cycles with any input/output SSE* or FP assists	
CCH	20H	ROB_MISC_EVENTS.LBR_INSERTS	Count cases of saving new LBR records by hardware.	
CDH	01H	MEM_TRANS_RETIRED.LOAD_LATENCY	Sample loads with specified latency threshold. PMC3 only.	Specify threshold in MSR 0x3F6
CDH	02H	MEM_TRANS_RETIRED.PRECISE_STORE	Sample stores and collect precise store operation via PEBS record. PMC3 only.	See Section 18.8.4.3

**Table 19-3. Non-Architectural Performance Events In the Processor Core Common to 2nd Generation Intel® Core™ i7-2xxx, Intel® Core™ i5-2xxx, Intel® Core™ i3-2xxx Processor Series and Intel® Xeon® Processors E5 Family**

Event Num.	Umask Value	Event Mask Mnemonic	Description	Comment
DOH	01H	MEM_UOP_RETIRE D.LOADS	Qualify retired memory uops that are loads. Combine with umask 10H, 20H, 40H, 80H.	Supports PEBS
DOH	02H	MEM_UOP_RETIRE D.STORES	Qualify retired memory uops that are stores. Combine with umask 10H, 20H, 40H, 80H.	
DOH	10H	MEM_UOP_RETIRE D.STLB_MISS	Qualify retired memory uops with STLB miss. Must combine with umask 01H, 02H, to produce counts.	
DOH	20H	MEM_UOP_RETIRE D.LOCK	Qualify retired memory uops with lock. Must combine with umask 01H, 02H, to produce counts.	
DOH	40H	MEM_UOP_RETIRE D.SPLIT	Qualify retired memory uops with line split. Must combine with umask 01H, 02H, to produce counts.	
DOH	80H	MEM_UOP_RETIRE D.ALL	Qualify any retired memory uops. Must combine with umask 01H, 02H, to produce counts.	
D1H	01H	MEM_LOAD_UOPS_R ETIRE.D.L1_HIT	Retired load uops with L1 cache hits as data sources.	Supports PEBS
D1H	02H	MEM_LOAD_UOPS_R ETIRE.D.L2_HIT	Retired load uops with L2 cache hits as data sources.	
D1H	40H	MEM_LOAD_UOPS_R ETIRE.D.HIT_LFB	Retired load uops which data sources were load uops missed L1 but hit FB due to preceding miss to the same cache line with data not ready.	
D2H	01H	MEM_LOAD_UOPS_L LC_HIT_RETIRE.D.XS NP_MISS	Retired load uops which data sources were LLC hit and cross-core snoop missed in on-pkg core cache.	Supports PEBS
D2H	02H	MEM_LOAD_UOPS_L LC_HIT_RETIRE.D.XS NP_HIT	Retired load uops which data sources were LLC and cross-core snoop hits in on-pkg core cache.	
D2H	04H	MEM_LOAD_UOPS_L LC_HIT_RETIRE.D.XS NP_HITM	Retired load uops which data sources were HitM responses from shared LLC.	

**Table 19-3. Non-Architectural Performance Events In the Processor Core Common to 2nd Generation Intel® Core™ i7-2xxx, Intel® Core™ i5-2xxx, Intel® Core™ i3-2xxx Processor Series and Intel® Xeon® Processors E5 Family**

Event Num.	Umask Value	Event Mask Mnemonic	Description	Comment
D2H	08H	MEM_LOAD_UOPS_LLC_HIT_RETIRED.XSNP_NONE	Retired load uops which data sources were hits in LLC without snoops required.	
D4H	02H	MEM_LOAD_UOPS_MISC_RETIRED.LLC_MISSES	Retired load uops with unknown information as data source in cache serviced the load.	Supports PEBS.
FOH	01H	L2_TRANS.DEMAND_DATA_RD	Demand Data Read requests that access L2 cache	
FOH	02H	L2_TRANS.RFO	RFO requests that access L2 cache	
FOH	04H	L2_TRANS.CODE_RD	L2 cache accesses when fetching instructions	
FOH	08H	L2_TRANS.ALL_PF	L2 or LLC HW prefetches that access L2 cache	including rejects.
FOH	10H	L2_TRANS.L1D_WB	L1D writebacks that access L2 cache	
FOH	20H	L2_TRANS.L2_FILL	L2 fill requests that access L2 cache	
FOH	40H	L2_TRANS.L2_WB	L2 writebacks that access L2 cache	
FOH	80H	L2_TRANS.ALL_REQUESTS	Transactions accessing L2 pipe	
F1H	01H	L2_LINES_IN.I	L2 cache lines in I state filling L2	Counting does not cover rejects.
F1H	02H	L2_LINES_IN.S	L2 cache lines in S state filling L2	Counting does not cover rejects.
F1H	04H	L2_LINES_IN.E	L2 cache lines in E state filling L2	Counting does not cover rejects.
F1H	07H	L2_LINES_IN.ALL	L2 cache lines filling L2	Counting does not cover rejects.
F2H	01H	L2_LINES_OUT.DEMAND_CLEAN	Clean L2 cache lines evicted by demand	
F2H	02H	L2_LINES_OUT.DEMAND_DIRTY	Dirty L2 cache lines evicted by demand	
F2H	04H	L2_LINES_OUT.PF_CLEAN	Clean L2 cache lines evicted by L2 prefetch	
F2H	08H	L2_LINES_OUT.PF_DIRTY	Dirty L2 cache lines evicted by L2 prefetch	

**Table 19-3. Non-Architectural Performance Events In the Processor Core Common to 2nd Generation Intel® Core™ i7-2xxx, Intel® Core™ i5-2xxx, Intel® Core™ i3-2xxx Processor Series and Intel® Xeon® Processors E5 Family**

Event Num.	Umask Value	Event Mask Mnemonic	Description	Comment
F2H	0AH	L2_LINES_OUT.DIRTY_ALL	Dirty L2 cache lines filling the L2	Counting does not cover rejects.
F4H	10H	SQ_MISC.SPLIT_LOCK	Split locks in SQ	

Non-architecture performance monitoring events in the processor core that are applicable only to Intel processor with CPUID signature of DisplayFamily\_DisplayModel 06\_2AH are listed in Table 19-4.

**Table 19-4. Non-Architectural Performance Events applicable only to the Processor core for 2nd Generation Intel® Core™ i7-2xxx, Intel® Core™ i5-2xxx, Intel® Core™ i3-2xxx Processor Series**

Event Num.	Umask Value	Event Mask Mnemonic	Description	Comment
D1H	04H	MEM_LOAD_UOPS_RETIRED.LLC_HIT	Retired load uops which data sources were data hits in LLC without snoops required.	Supports PEBS
B7H/BBH	01H	OFF_CORE_RESPONSE_N	Sub-events of OFF_CORE_RESPONSE_N (suffix N = 0, 1) programmed using MSR 01A6H/01A7H with values shown in the comment column.	
		OFFCORE_RESPONSE.ALL_CODE_RD.LLC_HIT_N		0x10003C0244
		OFFCORE_RESPONSE.ALL_CODE_RD.LLC_HIT.NO_SNOOP_NEEDED_N		0x1003C0244
		OFFCORE_RESPONSE.ALL_CODE_RD.LLC_HIT.SNOOP_MISS_N		0x2003C0244
		OFFCORE_RESPONSE.ALL_CODE_RD.LLC_HIT.MISS_DRAM_N		0x300400244
		OFFCORE_RESPONSE.ALL_DATA_RD.LLC_HIT.ANY_RESPONSE_N		0x3F803C0091
		OFFCORE_RESPONSE.ALL_DATA_RD.LLC_MISS.DRAM_N		0x300400091
		OFFCORE_RESPONSE.ALL_PF_CODE_RD.LLC_HIT.ANY_RESPONSE_N		0x3F803C0240
		OFFCORE_RESPONSE.ALL_PF_CODE_RD.LLC_HIT.HIT_OTHER_CORE_NO_FWD_N		0x4003C0240

**Table 19-4. Non-Architectural Performance Events applicable only to the Processor core for 2nd Generation Intel® Core™ i7-2xxx, Intel® Core™ i5-2xxx, Intel® Core™ i3-2xxx Processor Series**

Event Num.	Umask Value	Event Mask Mnemonic	Description	Comment
		OFFCORE_RESPONSE.ALL_PF_CODE_RD.LLC_HIT.HITM_OTHER_CORE_N		0x10003C0240
		OFFCORE_RESPONSE.ALL_PF_CODE_RD.LLC_HIT.NO_SNOOP_NEEDED_N		0x1003C0240
		OFFCORE_RESPONSE.ALL_PF_CODE_RD.LLC_HIT.SNOOP_MISSES_N		0x2003C0240
		OFFCORE_RESPONSE.ALL_PF_CODE_RD.LLC_MISS.DRAM_N		0x300400240
		OFFCORE_RESPONSE.ALL_PF_DATA_RD.LLC_MISS.DRAM_N		0x300400090
		OFFCORE_RESPONSE.ALL_PF_RFO.LLC_HIT.ANY_RESPONSE_N		0x3F803C0120
		OFFCORE_RESPONSE.ALL_PF_RFO.LLC_HIT.HIT_OTHER_CORE_NO_FWD_N		0x4003C0120
		OFFCORE_RESPONSE.ALL_PF_RFO.LLC_HIT.HITM_OTHER_CORE_N		0x10003C0120
		OFFCORE_RESPONSE.ALL_PF_RFO.LLC_HIT.NO_SNOOP_NEEDED_N		0x1003C0120
		OFFCORE_RESPONSE.ALL_PF_RFO.LLC_HIT.SNOOP_MISS_N		0x2003C0120
		OFFCORE_RESPONSE.ALL_PF_RFO.LLC_MISS.DRAM_N		0x300400120
		OFFCORE_RESPONSE.ALL_READS.LLC_MISS.DRAM_N		0x3004003F7
		OFFCORE_RESPONSE.ALL_RFO.LLC_HIT.ANY_RESPONSE_N		0x3F803C0122
		OFFCORE_RESPONSE.ALL_RFO.LLC_HIT.HIT_OTHER_CORE_NO_FWD_N		0x4003C0122
		OFFCORE_RESPONSE.ALL_RFO.LLC_HIT.HITM_OTHER_CORE_N		0x10003C0122
		OFFCORE_RESPONSE.ALL_RFO.LLC_HIT.NO_SNOOP_NEEDED_N		0x1003C0122
		OFFCORE_RESPONSE.ALL_RFO.LLC_HIT.SNOOP_MISS_N		0x2003C0122
		OFFCORE_RESPONSE.ALL_RFO.LLC_MISS.DRAM_N		0x300400122
		OFFCORE_RESPONSE.DEMAND_CODE_RD.LLC_HIT.HIT_OTHER_CORE_NO_FWD_N		0x4003C0004
		OFFCORE_RESPONSE.DEMAND_CODE_RD.LLC_HIT.HITM_OTHER_CORE_N		0x10003C0004

**Table 19-4. Non-Architectural Performance Events applicable only to the Processor core for 2nd Generation Intel® Core™ i7-2xxx, Intel® Core™ i5-2xxx, Intel® Core™ i3-2xxx Processor Series**

Event Num.	Umask Value	Event Mask Mnemonic	Description	Comment
		OFFCORE_RESPONSE.DEMAND_CODE_RD.LLC_HIT.NO_SNOOP_NEEDED_N		0x1003C0004
		OFFCORE_RESPONSE.DEMAND_CODE_RD.LLC_HIT.SNOOP_MISS_N		0x2003C0004
		OFFCORE_RESPONSE.DEMAND_CODE_RD.LLC_MISS.DRAM_N		0x300400004
		OFFCORE_RESPONSE.DEMAND_DATA_RD.LLC_MISS.DRAM_N		0x300400001
		OFFCORE_RESPONSE.DEMAND_RFO.LLC_HIT.ANY_RESPONSE_N		0x3F803C0002
		OFFCORE_RESPONSE.DEMAND_RFO.LLC_HIT.HIT_OTHER_CORE_NO_FWD_N		0x4003C0002
		OFFCORE_RESPONSE.DEMAND_RFO.LLC_HIT.HITM_OTHER_CORE_N		0x10003C0002
		OFFCORE_RESPONSE.DEMAND_RFO.LLC_HIT.NO_SNOOP_NEEDED_N		0x1003C0002
		OFFCORE_RESPONSE.DEMAND_RFO.LLC_HIT.SNOOP_MISS_N		0x2003C0002
		OFFCORE_RESPONSE.DEMAND_RFO.LLC_MISS.DRAM_N		0x300400002
		OFFCORE_RESPONSE.OTHER.ANY_RESPONSE_N		0x18000
		OFFCORE_RESPONSE.PF_L2_CODE_RD.LLC_HIT.HIT_OTHER_CORE_NO_FWD_N		0x4003C0040
		OFFCORE_RESPONSE.PF_L2_CODE_RD.LLC_HIT.HITM_OTHER_CORE_N		0x10003C0040
		OFFCORE_RESPONSE.PF_L2_CODE_RD.LLC_HIT.NO_SNOOP_NEEDED_N		0x1003C0040
		OFFCORE_RESPONSE.PF_L2_CODE_RD.LLC_HIT.SNOOP_MISS_N		0x2003C0040
		OFFCORE_RESPONSE.PF_L2_CODE_RD.LLC_MISS.DRAM_N		0x300400040
		OFFCORE_RESPONSE.PF_L2_DATA_RD.LLC_MISS.DRAM_N		0x300400010
		OFFCORE_RESPONSE.PF_L2_RFO.LLC_HIT.ANY_RESPONSE_N		0x3F803C0020
		OFFCORE_RESPONSE.PF_L2_RFO.LLC_HIT.HIT_OTHER_CORE_NO_FWD_N		0x4003C0020
		OFFCORE_RESPONSE.PF_L2_RFO.LLC_HIT.HITM_OTHER_CORE_N		0x10003C0020



**Table 19-4. Non-Architectural Performance Events applicable only to the Processor core for 2nd Generation Intel® Core™ i7-2xxx, Intel® Core™ i5-2xxx, Intel® Core™ i3-2xxx Processor Series**

Event Num.	Umask Value	Event Mask Mnemonic	Description	Comment
		OFFCORE_RESPONSE.PF_L2_RFO.LLC_HIT.NO_SNOOP_NEED_N		0x1003C0020
		OFFCORE_RESPONSE.PF_L2_RFO.LLC_HIT.SNOOP_MISS_N		0x2003C0020
		OFFCORE_RESPONSE.PF_L2_RFO.LLC_MISS.DRAM_N		0x300400020
		OFFCORE_RESPONSE.PF_LLC_CODE_RD.LLC_HIT.HIT_OTHER_CORE_NO_FWD_N		0x4003C0200
		OFFCORE_RESPONSE.PF_LLC_CODE_RD.LLC_HIT.HITM_OTHER_CORE_N		0x10003C0200
		OFFCORE_RESPONSE.PF_LLC_CODE_RD.LLC_HIT.NO_SNOOP_NEEDED_N		0x1003C0200
		OFFCORE_RESPONSE.PF_LLC_CODE_RD.LLC_HIT.SNOOP_MIS_S_N		0x2003C0200
		OFFCORE_RESPONSE.PF_LLC_CODE_RD.LLC_MISS.DRAM_N		0x300400200
		OFFCORE_RESPONSE.PF_LLC_DATA_RD.LLC_MISS.DRAM_N		0x300400080
		OFFCORE_RESPONSE.PF_LLC_RFO.LLC_HIT.ANY_RESPONSE_N		0x3F803C0100
		OFFCORE_RESPONSE.PF_LLC_RFO.LLC_HIT.HIT_OTHER_CORE_NO_FWD_N		0x4003C0100
		OFFCORE_RESPONSE.PF_LLC_RFO.LLC_HIT.HITM_OTHER_CORE_N		0x10003C0100
		OFFCORE_RESPONSE.PF_LLC_RFO.LLC_HIT.NO_SNOOP_NEEDED_N		0x1003C0100
		OFFCORE_RESPONSE.PF_LLC_RFO.LLC_HIT.SNOOP_MISS_N		0x2003C0100
		OFFCORE_RESPONSE.PF_LLC_RFO.LLC_MISS.DRAM_N		0x300400100

Non-architecture performance monitoring events in the processor core that are applicable only to Intel Xeon processor E5 family (and Intel Core i7-3930 processor) based on Intel microarchitecture Sandy Bridge, with CPUID signature of DisplayFamily\_DisplayModel 06\_2DH, are listed in Table 19-5.

**Table 19-5. Non-Architectural Performance Events Applicable only to the Processor Core of Intel® Xeon® Processor E5 Family**

Event Num.	Umask Value	Event Mask Mnemonic	Description	Comment
B7H/BBH	01H	OFF_CORE_RESPONSE_N	Sub-events of OFF_CORE_RESPONSE_N (suffix N = 0, 1) programmed using MSR 01A6H/01A7H with values shown in the comment column.	
		OFFCORE_RESPONSE.DEMAND_CODE_RD.LLC_MISS.ANY_RESPONSE_N		0x3FFFC0004
		OFFCORE_RESPONSE.DEMAND_CODE_RD.LLC_MISS.LOCAL_DRAM_N		0x600400004
		OFFCORE_RESPONSE.DEMAND_CODE_RD.LLC_MISS.REMOTE_DRAM_N		0x67F800004
		OFFCORE_RESPONSE.DEMAND_CODE_RD.LLC_MISS.REMOTE_HIT_FWD_N		0x87F800004
		OFFCORE_RESPONSE.DEMAND_CODE_RD.LLC_MISS.REMOTE_HITM_N		0x107FC0004
		OFFCORE_RESPONSE.DEMAND_DATA_RD.LLC_MISS.ANY_DRAM_N		0x67FC00001
		OFFCORE_RESPONSE.DEMAND_DATA_RD.LLC_MISS.ANY_RESPONSE_N		0x3F803C0001
		OFFCORE_RESPONSE.DEMAND_DATA_RD.LLC_MISS.LOCAL_DRAM_N		0x600400001
		OFFCORE_RESPONSE.DEMAND_DATA_RD.LLC_MISS.REMOTE_DRAM_N		0x67F800001
		OFFCORE_RESPONSE.DEMAND_DATA_RD.LLC_MISS.REMOTE_HIT_FWD_N		0x87F800001
		OFFCORE_RESPONSE.DEMAND_DATA_RD.LLC_MISS.REMOTE_HITM_N		0x107FC00001
		OFFCORE_RESPONSE.PF_L2_CODE_RD.LLC_MISS.ANY_RESPONSE_N		0x3F803C0040
		OFFCORE_RESPONSE.PF_L2_DATA_RD.LLC_MISS.ANY_DRAM_N		0x67FC00010
		OFFCORE_RESPONSE.PF_L2_DATA_RD.LLC_MISS.ANY_RESPONSE_N		0x3F803C0010
		OFFCORE_RESPONSE.PF_L2_DATA_RD.LLC_MISS.LOCAL_DRAM_N		0x600400010

**Table 19-5. Non-Architectural Performance Events Applicable only to the Processor Core of Intel® Xeon® Processor E5 Family**

Event Num.	Umask Value	Event Mask Mnemonic	Description	Comment
		OFFCORE_RESPONSE.PF_L2_DATA_RD.LLC_MISS.REMOTE_DRAM_N		0x67F800010
		OFFCORE_RESPONSE.PF_L2_DATA_RD.LLC_MISS.REMOTE_HIT_FWD_N		0x87F800010
		OFFCORE_RESPONSE.PF_L2_DATA_RD.LLC_MISS.REMOTE_HITM_N		0x107FC00010
		OFFCORE_RESPONSE.PF_LLC_CODE_RD.LLC_MISS.ANY_RESPONSE_N		0x3FFFC00200
		OFFCORE_RESPONSE.PF_LLC_DATA_RD.LLC_MISS.ANY_RESPONSE_N		0x3FFFC00080

Non-architectural Performance monitoring events that are located in the uncore subsystem are implementation specific between different platforms using processors based on Intel microarchitecture Sandy Bridge. Processors with CPUID signature of DisplayFamily\_DisplayModel 06\_2AH support performance events listed in Table 19-6.

**Table 19-6. Non-Architectural Performance Events in the Processor Uncore for 2nd Generation Intel® Core™ i7-2xxx, Intel® Core™ i5-2xxx, Intel® Core™ i3-2xxx Processor Series**

Event Num.	Umask Value	Event Mask Mnemonic	Description	Comment
22H	01H	UNC_CBO_XSNP_RESPONSE.RSPIHITI	Snoop responses received from processor cores to requests initiated by this Cbox.	Must combine with one of the umask values of 20H, 40H, 80H
22H	02H	UNC_CBO_XSNP_RESPONSE.RSPIHITFSE		
22H	04H	UNC_CBO_XSNP_RESPONSE.RSPSHITFSE		
22H	08H	UNC_CBO_XSNP_RESPONSE.RSPSFWDM		
22H	01H	UNC_CBO_XSNP_RESPONSE.RSPIFWDM		

**Table 19-6. Non-Architectural Performance Events In the Processor Uncore for 2nd Generation Intel® Core™ i7-2xxx, Intel® Core™ i5-2xxx, Intel® Core™ i3-2xxx Processor Series**

Event Num.	Umask Value	Event Mask Mnemonic	Description	Comment
22H	20H	UNC_CBO_XSNP_RESPONSE.AND_EXTERNAL	Filter on cross-core snoops resulted in external snoop request. Must combine with at least one of 01H, 02H, 04H, 08H, 10H	
22H	40H	UNC_CBO_XSNP_RESPONSE.AND_XCORE	Filter on cross-core snoops resulted in core request. Must combine with at least one of 01H, 02H, 04H, 08H, 10H	
22H	80H	UNC_CBO_XSNP_RESPONSE.AND_XCORE	Filter on cross-core snoops resulted in LLC evictions. Must combine with at least one of 01H, 02H, 04H, 08H, 10H	
34H	01H	UNC_CBO_CACHE_LOOKUP.M	LLC lookup request that access cache and found line in M-state.	Must combine with one of the umask values of 10H, 20H, 40H, 80H
34H	02H	UNC_CBO_CACHE_LOOKUP.E	LLC lookup request that access cache and found line in E-state.	
34H	04H	UNC_CBO_CACHE_LOOKUP.S	LLC lookup request that access cache and found line in S-state.	
34H	08H	UNC_CBO_CACHE_LOOKUP.I	LLC lookup request that access cache and found line in I-state.	
34H	10H	UNC_CBO_CACHE_LOOKUP.AND_READ	Filter on processor core initiated cacheable read requests. Must combine with at least one of 01H, 02H, 04H, 08H	
34H	20H	UNC_CBO_CACHE_LOOKUP.AND_READ	Filter on processor core initiated cacheable write requests. Must combine with at least one of 01H, 02H, 04H, 08H	
34H	40H	UNC_CBO_CACHE_LOOKUP.AND_EXTSNP	Filter on external snoop requests. Must combine with at least one of 01H, 02H, 04H, 08H	
34H	80H	UNC_CBO_CACHE_LOOKUP.AND_ANY	Filter on any IRQ or IPQ initiated requests including uncacheable, non-coherent requests. Must combine with at least one of 01H, 02H, 04H, 08H	

**Table 19-6. Non-Architectural Performance Events In the Processor Uncore for 2nd Generation Intel® Core™ i7-2xxx, Intel® Core™ i5-2xxx, Intel® Core™ i3-2xxx Processor Series**

Event Num.	Umask Value	Event Mask Mnemonic	Description	Comment
80H	01H	UNC_IMPH_CBO_TRK_OCCUPANCY.ALL	Counts cycles weighted by the number of core-outgoing valid entries. Valid entries are between allocation to the first of IDIO or DRSO messages. Accounts for coherent and in-coherent traffic	Counter 0 only
81H	01H	UNC_IMPH_CBO_TRK_REQUEST.ALL	Counts the number of core-outgoing entries. Accounts for coherent and in-coherent traffic	
81H	20H	UNC_IMPH_CBO_TRK_REQUEST.WRITES	Counts the number of allocated write entries, include full, partial, and evictions.	
81H	80H	UNC_IMPH_CBO_TRK_REQUEST.EVICTIONS	Counts the number of evictions allocated.	
83H	01H	UNC_IMPH_COH_TRK_OCCUPANCY.ALL	Counts cycles weighted by the number of core-outgoing valid entries in the coherent tracker queue.	Counter 0 only
84H	01H	UNC_IMPH_COH_TRK_REQUEST.ALL	Counts the number of core-outgoing entries in the coherent tracker queue.	

## 19.4 PERFORMANCE MONITORING EVENTS FOR INTEL® CORE™ I7 PROCESSOR FAMILY AND INTEL® XEON® PROCESSOR FAMILY

Processors based on the Intel microarchitecture code name Nehalem support the architectural and non-architectural performance-monitoring events listed in Table 19-1 and Table 19-7. The events in Table 19-7 generally applies to processors with CPUID signature of DisplayFamily\_DisplayModel encoding with the following values: 06\_1AH, 06\_1EH, 06\_1FH, and 06\_2EH. However, Intel Xeon processors with CPUID signature of DisplayFamily\_DisplayModel 06\_2EH have a small number of events that are not supported in processors with CPUID signature 06\_1AH, 06\_1EH, and 06\_1FH. These events are noted in the comment column.

## PERFORMANCE-MONITORING EVENTS

In addition, these processors (CUID signature of DisplayFamily\_DisplayModel 06\_1AH, 06\_1EH, 06\_1FH) also support the following non-architectural, product-specific uncore performance-monitoring events listed in Table 19-8.

Fixed counters in the core PMU support the architecture events defined in Table 19-12.

**Table 19-7. Non-Architectural Performance Events In the Processor Core for Intel® Core™ i7 Processor and Intel® Xeon® Processor 5500 Series**

Event Num.	Umask Value	Event Mask Mnemonic	Description	Comment
04H	07H	SB_DRAIN.ANY	Counts the number of store buffer drains.	
06H	04H	STORE_BLOCKS.AT_RET	Counts number of loads delayed with at-Retirement block code. The following loads need to be executed at retirement and wait for all senior stores on the same thread to be drained: load splitting across 4K boundary (page split), load accessing uncacheable (UC or USWC) memory, load lock, and load with page table in UC or USWC memory region.	
06H	08H	STORE_BLOCKS.L1D_BLOCK	Cacheable loads delayed with L1D block code.	
07H	01H	PARTIAL_ADDRESS_ALIAS	Counts false dependency due to partial address aliasing.	
08H	01H	DTLB_LOAD_MISSES.ANY	Counts all load misses that cause a page walk.	
08H	02H	DTLB_LOAD_MISSES.WALK_COMPLETED	Counts number of completed page walks due to load miss in the STLB.	
08H	10H	DTLB_LOAD_MISSES.STLB_HIT	Number of cache load STLB hits.	
08H	20H	DTLB_LOAD_MISSES.PDE_MISS	Number of DTLB cache load misses where the low part of the linear to physical address translation was missed.	
08H	80H	DTLB_LOAD_MISSES.LARGE_WALK_COMPLETED	Counts number of completed large page walks due to load miss in the STLB.	
0BH	01H	MEM_INST_RETIRED.LOADS	Counts the number of instructions with an architecturally-visible load retired on the architected path.	

**Table 19-7. Non-Architectural Performance Events In the Processor Core for Intel® Core™ i7 Processor and Intel® Xeon® Processor 5500 Series**

Event Num.	Umask Value	Event Mask Mnemonic	Description	Comment
OBH	02H	MEM_INST_RETIRED.STORES	Counts the number of instructions with an architecturally-visible store retired on the architected path.	
OBH	10H	MEM_INST_RETIRED.LATENCY_ABOVE_THRESHOLD	Counts the number of instructions exceeding the latency specified with Id_lat facility.	In conjunction with Id_lat facility
OCH	01H	MEM_STORE_RETIRE_D.DTLB_MISS	The event counts the number of retired stores that missed the DTLB. The DTLB miss is not counted if the store operation causes a fault. Does not counter prefetches. Counts both primary and secondary misses to the TLB.	
OEH	01H	UOPS_ISSUED.ANY	Counts the number of Uops issued by the Register Allocation Table to the Reservation Station, i.e. the UOPs issued from the front end to the back end.	
OEH	01H	UOPS_ISSUED.STALLED_CYCLES	Counts the number of cycles no Uops issued by the Register Allocation Table to the Reservation Station, i.e. the UOPs issued from the front end to the back end.	set "invert=1, cmask = 1"
OEH	02H	UOPS_ISSUED.FUSED	Counts the number of fused Uops that were issued from the Register Allocation Table to the Reservation Station.	
OFH	01H	MEM_UNCORE_RETIRED.L3_DATA_MISS_UNKNOWN	Counts number of memory load instructions retired where the memory reference missed L3 and data source is unknown.	Available only for CPUID signature 06_2EH
OFH	02H	MEM_UNCORE_RETIRED.OTHER_CORE_L2_HITM	Counts number of memory load instructions retired where the memory reference hit modified data in a sibling core residing on the same socket.	

**Table 19-7. Non-Architectural Performance Events In the Processor Core for Intel® Core™ i7 Processor and Intel® Xeon® Processor 5500 Series**

Event Num.	Umask Value	Event Mask Mnemonic	Description	Comment
0FH	08H	MEM_UNCORE_RETIRE.REMOTE_CACHE_LOCAL_HOME_HIT	Counts number of memory load instructions retired where the memory reference missed the L1, L2 and L3 caches and HIT in a remote socket's cache. Only counts locally homed lines.	
0FH	10H	MEM_UNCORE_RETIRE.REMOTE_DRAM	Counts number of memory load instructions retired where the memory reference missed the L1, L2 and L3 caches and was remotely homed. This includes both DRAM access and HITM in a remote socket's cache for remotely homed lines.	
0FH	20H	MEM_UNCORE_RETIRE.LOCAL_DRAM	Counts number of memory load instructions retired where the memory reference missed the L1, L2 and L3 caches and required a local socket memory reference. This includes locally homed cachelines that were in a modified state in another socket.	
0FH	80H	MEM_UNCORE_RETIRE.UNCACHEABLE	Counts number of memory load instructions retired where the memory reference missed the L1, L2 and L3 caches and to perform I/O.	Available only for CPUID signature 06_2EH
10H	01H	FP_COMP_OPS_EXE.X87	Counts the number of FP Computational Uops Executed. The number of FADD, FSUB, FCOM, FMULs, integer MULs and IMULs, FDIVs, FPREMs, FSQRTS, integer DIVs, and IDIVs. This event does not distinguish an FADD used in the middle of a transcendental flow from a separate FADD instruction.	
10H	02H	FP_COMP_OPS_EXE.MMX	Counts number of MMX Uops executed.	
10H	04H	FP_COMP_OPS_EXE.SSE_FP	Counts number of SSE and SSE2 FP uops executed.	



**Table 19-7. Non-Architectural Performance Events In the Processor Core for Intel® Core™ i7 Processor and Intel® Xeon® Processor 5500 Series**

Event Num.	Umask Value	Event Mask Mnemonic	Description	Comment
10H	08H	FP_COMP_OPS_EXE.SSE2_INTEGER	Counts number of SSE2 integer uops executed.	
10H	10H	FP_COMP_OPS_EXE.SSE_FP_PACKED	Counts number of SSE FP packed uops executed.	
10H	20H	FP_COMP_OPS_EXE.SSE_FP_SCALAR	Counts number of SSE FP scalar uops executed.	
10H	40H	FP_COMP_OPS_EXE.SSE_SINGLE_PRECISION	Counts number of SSE* FP single precision uops executed.	
10H	80H	FP_COMP_OPS_EXE.SSE_DOUBLE_PRECISION	Counts number of SSE* FP double precision uops executed.	
12H	01H	SIMD_INT_128.PACKED_MPY	Counts number of 128 bit SIMD integer multiply operations.	
12H	02H	SIMD_INT_128.PACKED_SHIFT	Counts number of 128 bit SIMD integer shift operations.	
12H	04H	SIMD_INT_128.PACK	Counts number of 128 bit SIMD integer pack operations.	
12H	08H	SIMD_INT_128.UNPACK	Counts number of 128 bit SIMD integer unpack operations.	
12H	10H	SIMD_INT_128.PACKED_LOGICAL	Counts number of 128 bit SIMD integer logical operations.	
12H	20H	SIMD_INT_128.PACKED_ARITH	Counts number of 128 bit SIMD integer arithmetic operations.	
12H	40H	SIMD_INT_128.SHUFFLE_MOVE	Counts number of 128 bit SIMD integer shuffle and move operations.	
13H	01H	LOAD_DISPATCH.RS	Counts number of loads dispatched from the Reservation Station that bypass the Memory Order Buffer.	
13H	02H	LOAD_DISPATCH.RS_DELAYED	Counts the number of delayed RS dispatches at the stage latch. If an RS dispatch can not bypass to LB, it has another chance to dispatch from the one-cycle delayed staging latch before it is written into the LB.	

**Table 19-7. Non-Architectural Performance Events In the Processor Core for Intel® Core™ i7 Processor and Intel® Xeon® Processor 5500 Series**

Event Num.	Umask Value	Event Mask Mnemonic	Description	Comment
13H	04H	LOAD_DISPATCH.MOB	Counts the number of loads dispatched from the Reservation Station to the Memory Order Buffer.	
13H	07H	LOAD_DISPATCH.ANY	Counts all loads dispatched from the Reservation Station.	
14H	01H	ARITH.CYCLES_DIV_BUSY	Counts the number of cycles the divider is busy executing divide or square root operations. The divide can be integer, X87 or Streaming SIMD Extensions (SSE). The square root operation can be either X87 or SSE.  Set 'edge =1, invert=1, cmask=1' to count the number of divides.	Count may be incorrect When SMT is on.
14H	02H	ARITH.MUL	Counts the number of multiply operations executed. This includes integer as well as floating point multiply operations but excludes DPPS mul and MPSAD.	Count may be incorrect When SMT is on
17H	01H	INST_QUEUE_WRITE_S	Counts the number of instructions written into the instruction queue every cycle.	
18H	01H	INST_DECODED.DECOD	Counts number of instructions that require decoder 0 to be decoded. Usually, this means that the instruction maps to more than 1 uop.	
19H	01H	TWO_UOP_INSTS_DECODED	An instruction that generates two uops was decoded.	

**Table 19-7. Non-Architectural Performance Events In the Processor Core for Intel® Core™ i7 Processor and Intel® Xeon® Processor 5500 Series**

Event Num.	Umask Value	Event Mask Mnemonic	Description	Comment
1EH	01H	INST_QUEUE_WRITE_CYCLES	This event counts the number of cycles during which instructions are written to the instruction queue. Dividing this counter by the number of instructions written to the instruction queue (INST_QUEUE_WRITES) yields the average number of instructions decoded each cycle. If this number is less than four and the pipe stalls, this indicates that the decoder is failing to decode enough instructions per cycle to sustain the 4-wide pipeline.	If SSE* instructions that are 6 bytes or longer arrive one after another, then front end throughput may limit execution speed. In such case,
20H	01H	LSD_OVERFLOW	Counts number of loops that can't stream from the instruction queue.	
24H	01H	L2_RQSTS.LD_HIT	Counts number of loads that hit the L2 cache. L2 loads include both L1D demand misses as well as L1D prefetches. L2 loads can be rejected for various reasons. Only non rejected loads are counted.	
24H	02H	L2_RQSTS.LD_MISS	Counts the number of loads that miss the L2 cache. L2 loads include both L1D demand misses as well as L1D prefetches.	
24H	03H	L2_RQSTS.LOADS	Counts all L2 load requests. L2 loads include both L1D demand misses as well as L1D prefetches.	
24H	04H	L2_RQSTS.RFO_HIT	Counts the number of store RFO requests that hit the L2 cache. L2 RFO requests include both L1D demand RFO misses as well as L1D RFO prefetches. Count includes WC memory requests, where the data is not fetched but the permission to write the line is required.	

**Table 19-7. Non-Architectural Performance Events In the Processor Core for Intel® Core™ i7 Processor and Intel® Xeon® Processor 5500 Series**

Event Num.	Umask Value	Event Mask Mnemonic	Description	Comment
24H	08H	L2_RQSTS.RFO_MISS	Counts the number of store RFO requests that miss the L2 cache. L2 RFO requests include both L1D demand RFO misses as well as L1D RFO prefetches.	
24H	0CH	L2_RQSTS.RFOS	Counts all L2 store RFO requests. L2 RFO requests include both L1D demand RFO misses as well as L1D RFO prefetches.	
24H	10H	L2_RQSTS.IFETCH_HIT	Counts number of instruction fetches that hit the L2 cache. L2 instruction fetches include both L1I demand misses as well as L1I instruction prefetches.	
24H	20H	L2_RQSTS.IFETCH_MISS	Counts number of instruction fetches that miss the L2 cache. L2 instruction fetches include both L1I demand misses as well as L1I instruction prefetches.	
24H	30H	L2_RQSTS.IFETCHES	Counts all instruction fetches. L2 instruction fetches include both L1I demand misses as well as L1I instruction prefetches.	
24H	40H	L2_RQSTS.PREFETCH_HIT	Counts L2 prefetch hits for both code and data.	
24H	80H	L2_RQSTS.PREFETCH_MISS	Counts L2 prefetch misses for both code and data.	
24H	COH	L2_RQSTS.PREFETCHES	Counts all L2 prefetches for both code and data.	
24H	AAH	L2_RQSTS.MISS	Counts all L2 misses for both code and data.	
24H	FFH	L2_RQSTS.REFERENCES	Counts all L2 requests for both code and data.	
26H	01H	L2_DATA_RQSTS.DEMAND_I_STATE	Counts number of L2 data demand loads where the cache line to be loaded is in the I (invalid) state, i.e. a cache miss. L2 demand loads are both L1D demand misses and L1D prefetches.	

**Table 19-7. Non-Architectural Performance Events In the Processor Core for Intel® Core™ i7 Processor and Intel® Xeon® Processor 5500 Series**

Event Num.	Umask Value	Event Mask Mnemonic	Description	Comment
26H	02H	L2_DATA_RQSTS.DEMAND.S_STATE	Counts number of L2 data demand loads where the cache line to be loaded is in the S (shared) state. L2 demand loads are both L1D demand misses and L1D prefetches.	
26H	04H	L2_DATA_RQSTS.DEMAND.E_STATE	Counts number of L2 data demand loads where the cache line to be loaded is in the E (exclusive) state. L2 demand loads are both L1D demand misses and L1D prefetches.	
26H	08H	L2_DATA_RQSTS.DEMAND.M_STATE	Counts number of L2 data demand loads where the cache line to be loaded is in the M (modified) state. L2 demand loads are both L1D demand misses and L1D prefetches.	
26H	0FH	L2_DATA_RQSTS.DEMAND.MESI	Counts all L2 data demand requests. L2 demand loads are both L1D demand misses and L1D prefetches.	
26H	10H	L2_DATA_RQSTS.PREFETCH.I_STATE	Counts number of L2 prefetch data loads where the cache line to be loaded is in the I (invalid) state, i.e. a cache miss.	
26H	20H	L2_DATA_RQSTS.PREFETCH.S_STATE	Counts number of L2 prefetch data loads where the cache line to be loaded is in the S (shared) state. A prefetch RFO will miss on an S state line, while a prefetch read will hit on an S state line.	
26H	40H	L2_DATA_RQSTS.PREFETCH.E_STATE	Counts number of L2 prefetch data loads where the cache line to be loaded is in the E (exclusive) state.	
26H	80H	L2_DATA_RQSTS.PREFETCH.M_STATE	Counts number of L2 prefetch data loads where the cache line to be loaded is in the M (modified) state.	
26H	F0H	L2_DATA_RQSTS.PREFETCH.MESI	Counts all L2 prefetch requests.	
26H	FFH	L2_DATA_RQSTS.ANY	Counts all L2 data requests.	

**Table 19-7. Non-Architectural Performance Events In the Processor Core for Intel® Core™ i7 Processor and Intel® Xeon® Processor 5500 Series**

Event Num.	Umask Value	Event Mask Mnemonic	Description	Comment
27H	01H	L2_WRITE.RFO.I_STATE	Counts number of L2 demand store RFO requests where the cache line to be loaded is in the I (invalid) state, i.e, a cache miss. The L1D prefetcher does not issue a RFO prefetch.	This is a demand RFO request
27H	02H	L2_WRITE.RFO.S_STATE	Counts number of L2 store RFO requests where the cache line to be loaded is in the S (shared) state. The L1D prefetcher does not issue a RFO prefetch.,.	This is a demand RFO request
27H	08H	L2_WRITE.RFO.M_STATE	Counts number of L2 store RFO requests where the cache line to be loaded is in the M (modified) state. The L1D prefetcher does not issue a RFO prefetch.	This is a demand RFO request
27H	0EH	L2_WRITE.RFO.HIT	Counts number of L2 store RFO requests where the cache line to be loaded is in either the S, E or M states. The L1D prefetcher does not issue a RFO prefetch.	This is a demand RFO request
27H	0FH	L2_WRITE.RFO.MESI	Counts all L2 store RFO requests. The L1D prefetcher does not issue a RFO prefetch.	This is a demand RFO request
27H	10H	L2_WRITE.LOCK.I_STATE	Counts number of L2 demand lock RFO requests where the cache line to be loaded is in the I (invalid) state, i.e. a cache miss.	
27H	20H	L2_WRITE.LOCK.S_STATE	Counts number of L2 lock RFO requests where the cache line to be loaded is in the S (shared) state.	
27H	40H	L2_WRITE.LOCK.E_STATE	Counts number of L2 demand lock RFO requests where the cache line to be loaded is in the E (exclusive) state.	
27H	80H	L2_WRITE.LOCK.M_STATE	Counts number of L2 demand lock RFO requests where the cache line to be loaded is in the M (modified) state.	

**Table 19-7. Non-Architectural Performance Events In the Processor Core for Intel® Core™ i7 Processor and Intel® Xeon® Processor 5500 Series**

Event Num.	Umask Value	Event Mask Mnemonic	Description	Comment
27H	E0H	L2_WRITE.LOCK.HIT	Counts number of L2 demand lock RFO requests where the cache line to be loaded is in either the S, E, or M state.	
27H	F0H	L2_WRITE.LOCK.MESI	Counts all L2 demand lock RFO requests.	
28H	01H	L1D_WB_L2.I_STATE	Counts number of L1 writebacks to the L2 where the cache line to be written is in the I (invalid) state, i.e. a cache miss.	
28H	02H	L1D_WB_L2.S_STAT E	Counts number of L1 writebacks to the L2 where the cache line to be written is in the S state.	
28H	04H	L1D_WB_L2.E_STAT E	Counts number of L1 writebacks to the L2 where the cache line to be written is in the E (exclusive) state.	
28H	08H	L1D_WB_L2.M_STAT E	Counts number of L1 writebacks to the L2 where the cache line to be written is in the M (modified) state.	
28H	0FH	L1D_WB_L2.MESI	Counts all L1 writebacks to the L2 .	
2EH	4FH	L3_LAT_CACHE.REFERENCE	This event counts requests originating from the core that reference a cache line in the last level cache. The event count includes speculative traffic but excludes cache line fills due to a L2 hardware-prefetch. Because cache hierarchy, cache sizes and other implementation-specific characteristics; value comparison to estimate performance differences is not recommended.	see Table 19-1

**Table 19-7. Non-Architectural Performance Events In the Processor Core for Intel® Core™ i7 Processor and Intel® Xeon® Processor 5500 Series**

Event Num.	Umask Value	Event Mask Mnemonic	Description	Comment
2EH	41H	L3_LAT_CACHE.MISS	This event counts each cache miss condition for references to the last level cache. The event count may include speculative traffic but excludes cache line fills due to L2 hardware-prefetches. Because cache hierarchy, cache sizes and other implementation-specific characteristics; value comparison to estimate performance differences is not recommended.	see Table 19-1
3CH	00H	CPU_CLK_UNHALTED.THREAD_P	Counts the number of thread cycles while the thread is not in a halt state. The thread enters the halt state when it is running the HLT instruction. The core frequency may change from time to time due to power or thermal throttling.	see Table 19-1
3CH	01H	CPU_CLK_UNHALTED.REF_P	Increments at the frequency of TSC when not halted.	see Table 19-1
40H	01H	L1D_CACHE_LD.I_STATE	Counts L1 data cache read requests where the cache line to be loaded is in the I (invalid) state, i.e. the read request missed the cache.	Counter 0, 1 only
40H	02H	L1D_CACHE_LD.S_STATE	Counts L1 data cache read requests where the cache line to be loaded is in the S (shared) state.	Counter 0, 1 only
40H	04H	L1D_CACHE_LD.E_STATE	Counts L1 data cache read requests where the cache line to be loaded is in the E (exclusive) state.	Counter 0, 1 only
40H	08H	L1D_CACHE_LD.M_STATE	Counts L1 data cache read requests where the cache line to be loaded is in the M (modified) state.	Counter 0, 1 only
40H	0FH	L1D_CACHE_LD.MESI	Counts L1 data cache read requests.	Counter 0, 1 only
41H	02H	L1D_CACHE_ST.S_STATE	Counts L1 data cache store RFO requests where the cache line to be loaded is in the S (shared) state.	Counter 0, 1 only



**Table 19-7. Non-Architectural Performance Events In the Processor Core for Intel® Core™ i7 Processor and Intel® Xeon® Processor 5500 Series**

Event Num.	Umask Value	Event Mask Mnemonic	Description	Comment
41H	04H	L1D_CACHE_ST.E_STATE	Counts L1 data cache store RFO requests where the cache line to be loaded is in the E (exclusive) state.	Counter 0, 1 only
41H	08H	L1D_CACHE_ST.M_STATE	Counts L1 data cache store RFO requests where cache line to be loaded is in the M (modified) state.	Counter 0, 1 only
42H	01H	L1D_CACHE_LOCK.HIT	Counts retired load locks that hit in the L1 data cache or hit in an already allocated fill buffer. The lock portion of the load lock transaction must hit in the L1D.	The initial load will pull the lock into the L1 data cache. Counter 0, 1 only
42H	02H	L1D_CACHE_LOCK.S_STATE	Counts L1 data cache retired load locks that hit the target cache line in the shared state.	Counter 0, 1 only
42H	04H	L1D_CACHE_LOCK.E_STATE	Counts L1 data cache retired load locks that hit the target cache line in the exclusive state.	Counter 0, 1 only
42H	08H	L1D_CACHE_LOCK.M_STATE	Counts L1 data cache retired load locks that hit the target cache line in the modified state.	Counter 0, 1 only
43H	01H	L1D_ALL_REF.ANY	Counts all references (uncached, speculated and retired) to the L1 data cache, including all loads and stores with any memory types. The event counts memory accesses only when they are actually performed. For example, a load blocked by unknown store address and later performed is only counted once.	The event does not include non-memory accesses, such as I/O accesses. Counter 0, 1 only
43H	02H	L1D_ALL_REF.CACHEABLE	Counts all data reads and writes (speculated and retired) from cacheable memory, including locked operations.	Counter 0, 1 only
49H	01H	DTLB_MISSES.ANY	Counts the number of misses in the STLB which causes a page walk.	
49H	02H	DTLB_MISSES.WALK_COMPLETED	Counts number of misses in the STLB which resulted in a completed page walk.	

**Table 19-7. Non-Architectural Performance Events In the Processor Core for Intel® Core™ i7 Processor and Intel® Xeon® Processor 5500 Series**

Event Num.	Umask Value	Event Mask Mnemonic	Description	Comment
49H	10H	DTLB_MISSES.STLB_HIT	Counts the number of DTLB first level misses that hit in the second level TLB. This event is only relevant if the core contains multiple DTLB levels.	
49H	20H	DTLB_MISSES.PDE_MISS	Number of DTLB misses caused by low part of address, includes references to 2M pages because 2M pages do not use the PDE.	
49H	80H	DTLB_MISSES.LARGE_WALK_COMPLETED	Counts number of misses in the STLB which resulted in a completed page walk for large pages.	
4CH	01H	LOAD_HIT_PRE	Counts load operations sent to the L1 data cache while a previous SSE prefetch instruction to the same cache line has started prefetching but has not yet finished.	
4EH	01H	L1D_PREFETCH.REQUESTS	Counts number of hardware prefetch requests dispatched out of the prefetch FIFO.	
4EH	02H	L1D_PREFETCH.MISS	Counts number of hardware prefetch requests that miss the L1D. There are two prefetchers in the L1D. A streamer, which predicts lines sequentially after this one should be fetched, and the IP prefetcher that remembers access patterns for the current instruction. The streamer prefetcher stops on an L1D hit, while the IP prefetcher does not.	
4EH	04H	L1D_PREFETCH.TRIGGERS	Counts number of prefetch requests triggered by the Finite State Machine and pushed into the prefetch FIFO. Some of the prefetch requests are dropped due to overwrites or competition between the IP index prefetcher and streamer prefetcher. The prefetch FIFO contains 4 entries.	

**Table 19-7. Non-Architectural Performance Events In the Processor Core for Intel® Core™ i7 Processor and Intel® Xeon® Processor 5500 Series**

Event Num.	Umask Value	Event Mask Mnemonic	Description	Comment
51H	01H	L1D.REPL	Counts the number of lines brought into the L1 data cache.	Counter 0, 1 only
51H	02H	L1D.M_REPL	Counts the number of modified lines brought into the L1 data cache.	Counter 0, 1 only
51H	04H	L1D.M_EVICT	Counts the number of modified lines evicted from the L1 data cache due to replacement.	Counter 0, 1 only
51H	08H	L1D.M_SNOOP_EVICT	Counts the number of modified lines evicted from the L1 data cache due to snoop HITM intervention.	Counter 0, 1 only
52H	01H	L1D_CACHE_PREFETCH_LOCK_FB_HIT	Counts the number of cacheable load lock speculated instructions accepted into the fill buffer.	
53H	01H	L1D_CACHE_LOCK_FB_HIT	Counts the number of cacheable load lock speculated or retired instructions accepted into the fill buffer.	
63H	01H	CACHE_LOCK_CYCLE S.L1D_L2	Cycle count during which the L1D and L2 are locked. A lock is asserted when there is a locked memory access, due to uncacheable memory, a locked operation that spans two cache lines, or a page walk from an uncacheable page table.	Counter 0, 1 only. L1D and L2 locks have a very high performance penalty and it is highly recommended to avoid such accesses.
63H	02H	CACHE_LOCK_CYCLE S.L1D	Counts the number of cycles that cacheline in the L1 data cache unit is locked.	Counter 0, 1 only.
6CH	01H	IO_TRANSACTIONS	Counts the number of completed I/O transactions.	
80H	01H	L1I.HITS	Counts all instruction fetches that hit the L1 instruction cache.	

**Table 19-7. Non-Architectural Performance Events In the Processor Core for Intel® Core™ i7 Processor and Intel® Xeon® Processor 5500 Series**

Event Num.	Umask Value	Event Mask Mnemonic	Description	Comment
80H	02H	L1I.MISSES	Counts all instruction fetches that miss the L1I cache. This includes instruction cache misses, streaming buffer misses, victim cache misses and uncacheable fetches. An instruction fetch miss is counted only once and not once for every cycle it is outstanding.	
80H	03H	L1I.READS	Counts all instruction fetches, including uncacheable fetches that bypass the L1I.	
80H	04H	L1I.CYCLES_STALLED	Cycle counts for which an instruction fetch stalls due to a L1I cache miss, ITLB miss or ITLB fault.	
82H	01H	LARGE_ITLB.HIT	Counts number of large ITLB hits.	
85H	01H	ITLB_MISSES.ANY	Counts the number of misses in all levels of the ITLB which causes a page walk.	
85H	02H	ITLB_MISSES.WALK_COMPLETED	Counts number of misses in all levels of the ITLB which resulted in a completed page walk.	
87H	01H	ILD_STALL.LCP	Cycles Instruction Length Decoder stalls due to length changing prefixes: 66, 67 or REX.W (for EM64T) instructions which change the length of the decoded instruction.	
87H	02H	ILD_STALL.MRU	Instruction Length Decoder stall cycles due to Branch Prediction Unit (PBU) Most Recently Used (MRU) bypass.	
87H	04H	ILD_STALL.IQ_FULL	Stall cycles due to a full instruction queue.	
87H	08H	ILD_STALL.REGEN	Counts the number of regen stalls.	
87H	0FH	ILD_STALL.ANY	Counts any cycles the Instruction Length Decoder is stalled.	

**Table 19-7. Non-Architectural Performance Events In the Processor Core for Intel® Core™ i7 Processor and Intel® Xeon® Processor 5500 Series**

Event Num.	Umask Value	Event Mask Mnemonic	Description	Comment
88H	01H	BR_INST_EXEC.COND	Counts the number of conditional near branch instructions executed, but not necessarily retired.	
88H	02H	BR_INST_EXEC.DIRECT	Counts all unconditional near branch instructions excluding calls and indirect branches.	
88H	04H	BR_INST_EXEC.INDIRECT_NON_CALL	Counts the number of executed indirect near branch instructions that are not calls.	
88H	07H	BR_INST_EXEC.NON_CALLS	Counts all non call near branch instructions executed, but not necessarily retired.	
88H	08H	BR_INST_EXEC.RETURN_NEAR	Counts indirect near branches that have a return mnemonic.	
88H	10H	BR_INST_EXEC.DIRECT_NEAR_CALL	Counts unconditional near call branch instructions, excluding non call branch, executed.	
88H	20H	BR_INST_EXEC.INDIRECT_NEAR_CALL	Counts indirect near calls, including both register and memory indirect, executed.	
88H	30H	BR_INST_EXEC.NEAR_CALLS	Counts all near call branches executed, but not necessarily retired.	
88H	40H	BR_INST_EXEC.TAKEN	Counts taken near branches executed, but not necessarily retired.	
88H	7FH	BR_INST_EXEC.ANY	Counts all near executed branches (not necessarily retired). This includes only instructions and not micro-op branches. Frequent branching is not necessarily a major performance issue. However frequent branch mispredictions may be a problem.	
89H	01H	BR_MISP_EXEC.COND	Counts the number of mispredicted conditional near branch instructions executed, but not necessarily retired.	

**Table 19-7. Non-Architectural Performance Events In the Processor Core for Intel® Core™ i7 Processor and Intel® Xeon® Processor 5500 Series**

Event Num.	Umask Value	Event Mask Mnemonic	Description	Comment
89H	02H	BR_MISP_EXEC.DIRECT	Counts mispredicted macro unconditional near branch instructions, excluding calls and indirect branches (should always be 0).	
89H	04H	BR_MISP_EXEC.INDIRECT_NON_CALL	Counts the number of executed mispredicted indirect near branch instructions that are not calls.	
89H	07H	BR_MISP_EXEC.NON_CALLS	Counts mispredicted non call near branches executed, but not necessarily retired.	
89H	08H	BR_MISP_EXEC.RETURN_NEAR	Counts mispredicted indirect branches that have a rear return mnemonic.	
89H	10H	BR_MISP_EXEC.DIRECT_NEAR_CALL	Counts mispredicted non-indirect near calls executed, (should always be 0).	
89H	20H	BR_MISP_EXEC.INDIRECT_NEAR_CALL	Counts mispredicted indirect near calls executed, including both register and memory indirect.	
89H	30H	BR_MISP_EXEC.NEAR_CALLS	Counts all mispredicted near call branches executed, but not necessarily retired.	
89H	40H	BR_MISP_EXEC.TAKEN	Counts executed mispredicted near branches that are taken, but not necessarily retired.	
89H	7FH	BR_MISP_EXEC.ANY	Counts the number of mispredicted near branch instructions that were executed, but not necessarily retired.	

**Table 19-7. Non-Architectural Performance Events In the Processor Core for Intel® Core™ i7 Processor and Intel® Xeon® Processor 5500 Series**

Event Num.	Umask Value	Event Mask Mnemonic	Description	Comment
A2H	01H	RESOURCE_STALLS.ANY	Counts the number of Allocator resource related stalls. Includes register renaming buffer entries, memory buffer entries. In addition to resource related stalls, this event counts some other events. Includes stalls arising during branch misprediction recovery, such as if retirement of the mispredicted branch is delayed and stalls arising while store buffer is draining from synchronizing operations.	Does not include stalls due to SuperQ (off core) queue full, too many cache misses, etc.
A2H	02H	RESOURCE_STALLS.LOAD	Counts the cycles of stall due to lack of load buffer for load operation.	
A2H	04H	RESOURCE_STALLS.RES_FULL	This event counts the number of cycles when the number of instructions in the pipeline waiting for execution reaches the limit the processor can handle. A high count of this event indicates that there are long latency operations in the pipe (possibly load and store operations that miss the L2 cache, or instructions dependent upon instructions further down the pipeline that have yet to retire.	When RS is full, new instructions can not enter the reservation station and start execution.
A2H	08H	RESOURCE_STALLS.STORE	This event counts the number of cycles that a resource related stall will occur due to the number of store instructions reaching the limit of the pipeline, (i.e. all store buffers are used). The stall ends when a store instruction commits its data to the cache or memory.	
A2H	10H	RESOURCE_STALLS.REORDER_FULL	Counts the cycles of stall due to re-order buffer full.	
A2H	20H	RESOURCE_STALLS.FPCW	Counts the number of cycles while execution was stalled due to writing the floating-point unit (FPU) control word.	

**Table 19-7. Non-Architectural Performance Events In the Processor Core for Intel® Core™ i7 Processor and Intel® Xeon® Processor 5500 Series**

Event Num.	Umask Value	Event Mask Mnemonic	Description	Comment
A2H	40H	RESOURCE_STALLS.MXCSR	Stalls due to the MXCSR register rename occurring to close to a previous MXCSR rename. The MXCSR provides control and status for the MMX registers.	
A2H	80H	RESOURCE_STALLS.OTHER	Counts the number of cycles while execution was stalled due to other resource issues.	
A6H	01H	MACRO_INSTS.FUSIONNS_DECODED	Counts the number of instructions decoded that are macro-fused but not necessarily executed or retired.	
A7H	01H	BACLEAR_FORCE_IQ	Counts number of times a BACLEAR was forced by the Instruction Queue. The IQ is also responsible for providing conditional branch prediction direction based on a static scheme and dynamic data provided by the L2 Branch Prediction Unit. If the conditional branch target is not found in the Target Array and the IQ predicts that the branch is taken, then the IQ will force the Branch Address Calculator to issue a BACLEAR. Each BACLEAR asserted by the BAC generates approximately an 8 cycle bubble in the instruction fetch pipeline.	
A8H	01H	LSD.UOPS	Counts the number of micro-ops delivered by loop stream detector.	Use cmask=1 and invert to count cycles
AEH	01H	ITLB_FLUSH	Counts the number of ITLB flushes.	
BOH	40H	OFFCORE_REQUESTS.L1D_WRITEBACK	Counts number of L1D writebacks to the uncore.	
B1H	01H	UOPS_EXECUTED.PORT0	Counts number of Uops executed that were issued on port 0. Port 0 handles integer arithmetic, SIMD and FP add Uops.	



**Table 19-7. Non-Architectural Performance Events In the Processor Core for Intel® Core™ i7 Processor and Intel® Xeon® Processor 5500 Series**

Event Num.	Umask Value	Event Mask Mnemonic	Description	Comment
B1H	02H	UOPS_EXECUTED.PORT1	Counts number of Uops executed that were issued on port 1. Port 1 handles integer arithmetic, SIMD, integer shift, FP multiply and FP divide Uops.	
B1H	04H	UOPS_EXECUTED.PORT2_CORE	Counts number of Uops executed that were issued on port 2. Port 2 handles the load Uops. This is a core count only and can not be collected per thread.	
B1H	08H	UOPS_EXECUTED.PORT3_CORE	Counts number of Uops executed that were issued on port 3. Port 3 handles store Uops. This is a core count only and can not be collected per thread.	
B1H	10H	UOPS_EXECUTED.PORT4_CORE	Counts number of Uops executed that where issued on port 4. Port 4 handles the value to be stored for the store Uops issued on port 3. This is a core count only and can not be collected per thread.	
B1H	1FH	UOPS_EXECUTED.CORE_ACTIVE_CYCLES_NO_PORT5	Counts cycles when the Uops executed were issued from any ports except port 5. Use Cmask=1 for active cycles; Cmask=0 for weighted cycles; Use CMask=1, Invert=1 to count PO-4 stalled cycles Use Cmask=1, Edge=1, Invert=1 to count PO-4 stalls.	
B1H	20H	UOPS_EXECUTED.PORT5	Counts number of Uops executed that where issued on port 5.	
B1H	3FH	UOPS_EXECUTED.CORE_ACTIVE_CYCLES	Counts cycles when the Uops are executing . Use Cmask=1 for active cycles; Cmask=0 for weighted cycles; Use CMask=1, Invert=1 to count PO-4 stalled cycles Use Cmask=1, Edge=1, Invert=1 to count PO-4 stalls.	

**Table 19-7. Non-Architectural Performance Events In the Processor Core for Intel® Core™ i7 Processor and Intel® Xeon® Processor 5500 Series**

Event Num.	Umask Value	Event Mask Mnemonic	Description	Comment
B1H	40H	UOPS_EXECUTED.PORT015	Counts number of Uops executed that were issued on port 0, 1, or 5.	use cmask=1, invert=1 to count stall cycles
B1H	80H	UOPS_EXECUTED.PORT234	Counts number of Uops executed that were issued on port 2, 3, or 4.	
B2H	01H	OFFCORE_REQUESTS_SQ_FULL	Counts number of cycles the SQ is full to handle off-core requests.	
B7H	01H	OFF_CORE_RESPONSE_0	see Section 18.6.1.3, "Off-core Response Performance Monitoring in the Processor Core".	Requires programming MSR 01A6H
B8H	01H	SNOOP_RESPONSE_HIT	Counts HIT snoop response sent by this thread in response to a snoop request.	
B8H	02H	SNOOP_RESPONSE_HIT_E	Counts HIT E snoop response sent by this thread in response to a snoop request.	
B8H	04H	SNOOP_RESPONSE_HIT_M	Counts HIT M snoop response sent by this thread in response to a snoop request.	
BBH	01H	OFF_CORE_RESPONSE_1	See Section 18.7, "Performance Monitoring for Processors Based on Intel® Microarchitecture Code Name Westmere".	Requires programming MSR 01A7H
COH	00H	INST_RETIRED.ANY_P	See Table 19-1 Notes: INST_RETIRED.ANY is counted by a designated fixed counter. INST_RETIRED.ANY_P is counted by a programmable counter and is an architectural performance event. Event is supported if CPUID.A.EBX[1] = 0.	Counting: Faulting executions of GETSEC/VM entry/VM Exit/MWait will not count as retired instructions.
COH	02H	INST_RETIRED.X87	Counts the number of MMX instructions retired.	

**Table 19-7. Non-Architectural Performance Events In the Processor Core for Intel® Core™ i7 Processor and Intel® Xeon® Processor 5500 Series**

Event Num.	Umask Value	Event Mask Mnemonic	Description	Comment
C0H	04H	INST_RETIRED.MMX	Counts the number of floating point computational operations retired: floating point computational operations executed by the assist handler and sub-operations of complex floating point instructions like transcendental instructions.	
C2H	01H	UOPS_RETIRED.ANY	Counts the number of micro-ops retired, (macro-fused=1, micro-fused=2, others=1; maximum count of 8 per cycle). Most instructions are composed of one or two micro-ops. Some instructions are decoded into longer sequences such as repeat instructions, floating point transcendental instructions, and assists.	Use cmask=1 and invert to count active cycles or stalled cycles
C2H	02H	UOPS_RETIRED.RETI RE_SLOTS	Counts the number of retirement slots used each cycle.	
C2H	04H	UOPS_RETIRED.MAC RO_FUSED	Counts number of macro-fused uops retired.	
C3H	01H	MACHINE_CLEAR.S CYCLES	Counts the cycles machine clear is asserted.	
C3H	02H	MACHINE_CLEAR.M EM_ORDER	Counts the number of machine clears due to memory order conflicts.	
C3H	04H	MACHINE_CLEAR.S MC	Counts the number of times that a program writes to a code section. Self-modifying code causes a severe penalty in all Intel 64 and IA-32 processors. The modified cache line is written back to the L2 and L3caches.	
C4H	00H	BR_INST_RETIRED.A LL_BRANCHES	Branch instructions at retirement	See Table 19-1
C4H	01H	BR_INST_RETIRED.C ONDITIONAL	Counts the number of conditional branch instructions retired.	

**Table 19-7. Non-Architectural Performance Events In the Processor Core for Intel® Core™ i7 Processor and Intel® Xeon® Processor 5500 Series**

Event Num.	Umask Value	Event Mask Mnemonic	Description	Comment
C4H	02H	BR_INST_RETIRED.NEAR_CALL	Counts the number of direct & indirect near unconditional calls retired.	
C5H	00H	BR_MISP_RETIRED.ALL_BRANCHES	Mispredicted branch instructions at retirement	See Table 19-1
C5H	02H	BR_MISP_RETIRED.NEAR_CALL	Counts mispredicted direct & indirect near unconditional retired calls.	
C7H	01H	SSEX_UOPS_RETIREDD.PACKED_SINGLE	Counts SIMD packed single-precision floating point Uops retired.	
C7H	02H	SSEX_UOPS_RETIREDD.SCALAR_SINGLE	Counts SIMD calar single-precision floating point Uops retired.	
C7H	04H	SSEX_UOPS_RETIREDD.PACKED_DOUBLE	Counts SIMD packed double-precision floating point Uops retired.	
C7H	08H	SSEX_UOPS_RETIREDD.SCALAR_DOUBLE	Counts SIMD scalar double-precision floating point Uops retired.	
C7H	10H	SSEX_UOPS_RETIREDD.VECTOR_INTEGER	Counts 128-bit SIMD vector integer Uops retired.	
C8H	20H	ITLB_MISS_RETIRED	Counts the number of retired instructions that missed the ITLB when the instruction was fetched.	
CBH	01H	MEM_LOAD_RETIRED.L1D_HIT	Counts number of retired loads that hit the L1 data cache.	
CBH	02H	MEM_LOAD_RETIRED.L2_HIT	Counts number of retired loads that hit the L2 data cache.	
CBH	04H	MEM_LOAD_RETIRED.L3_UNSHARED_HIT	Counts number of retired loads that hit their own, unshared lines in the L3 cache.	
CBH	08H	MEM_LOAD_RETIRED.OTHER_CORE_L2_HIT_HITM	Counts number of retired loads that hit in a sibling core's L2 (on die core). Since the L3 is inclusive of all cores on the package, this is an L3 hit. This counts both clean or modified hits.	
CBH	10H	MEM_LOAD_RETIRED.L3_MISS	Counts number of retired loads that miss the L3 cache. The load was satisfied by a remote socket, local memory or an IOH.	

**Table 19-7. Non-Architectural Performance Events In the Processor Core for Intel® Core™ i7 Processor and Intel® Xeon® Processor 5500 Series**

Event Num.	Umask Value	Event Mask Mnemonic	Description	Comment
CBH	40H	MEM_LOAD_RETIRED.HIT_LFB	Counts number of retired loads that miss the L1D and the address is located in an allocated line fill buffer and will soon be committed to cache. This is counting secondary L1D misses.	
CBH	80H	MEM_LOAD_RETIRED.DTLB_MISS	Counts the number of retired loads that missed the DTLB. The DTLB miss is not counted if the load operation causes a fault. This event counts loads from cacheable memory only. The event does not count loads by software prefetches. Counts both primary and secondary misses to the TLB.	
CCH	01H	FP_MMX_TRANS.TO_FP	Counts the first floating-point instruction following any MMX instruction. You can use this event to estimate the penalties for the transitions between floating-point and MMX technology states.	
CCH	02H	FP_MMX_TRANS.TO_MMX	Counts the first MMX instruction following a floating-point instruction. You can use this event to estimate the penalties for the transitions between floating-point and MMX technology states.	
CCH	03H	FP_MMX_TRANS.ANY	Counts all transitions from floating point to MMX instructions and from MMX instructions to floating point instructions. You can use this event to estimate the penalties for the transitions between floating-point and MMX technology states.	
DOH	01H	MACRO_INSTS.DECODED	Counts the number of instructions decoded, (but not necessarily executed or retired).	

**Table 19-7. Non-Architectural Performance Events In the Processor Core for Intel® Core™ i7 Processor and Intel® Xeon® Processor 5500 Series**

Event Num.	Umask Value	Event Mask Mnemonic	Description	Comment
D1H	02H	UOPS_DECODED.MS	Counts the number of Uops decoded by the Microcode Sequencer, MS. The MS delivers uops when the instruction is more than 4 uops long or a microcode assist is occurring.	
D1H	04H	UOPS_DECODED.ESP_FOLDING	Counts number of stack pointer (ESP) instructions decoded: push , pop , call , ret, etc. ESP instructions do not generate a Uop to increment or decrement ESP. Instead, they update an ESP_Offset register that keeps track of the delta to the current value of the ESP register.	
D1H	08H	UOPS_DECODED.ESP_SYNC	Counts number of stack pointer (ESP) sync operations where an ESP instruction is corrected by adding the ESP offset register to the current value of the ESP register.	
D2H	01H	RAT_STALLS.FLAGS	Counts the number of cycles during which execution stalled due to several reasons, one of which is a partial flag register stall. A partial register stall may occur when two conditions are met: 1) an instruction modifies some, but not all, of the flags in the flag register and 2) the next instruction, which depends on flags, depends on flags that were not modified by this instruction.	
D2H	02H	RAT_STALLS.REGISTERS	This event counts the number of cycles instruction execution latency became longer than the defined latency because the instruction used a register that was partially written by previous instruction.	

**Table 19-7. Non-Architectural Performance Events In the Processor Core for Intel® Core™ i7 Processor and Intel® Xeon® Processor 5500 Series**

Event Num.	Umask Value	Event Mask Mnemonic	Description	Comment
D2H	04H	RAT_STALLS.ROB_READ_PORT	Counts the number of cycles when ROB read port stalls occurred, which did not allow new micro-ops to enter the out-of-order pipeline. Note that, at this stage in the pipeline, additional stalls may occur at the same cycle and prevent the stalled micro-ops from entering the pipe. In such a case, micro-ops retry entering the execution pipe in the next cycle and the ROB-read port stall is counted again.	
D2H	08H	RAT_STALLS.SCOREBOARD	Counts the cycles where we stall due to microarchitecturally required serialization. Microcode scoreboarding stalls.	
D2H	0FH	RAT_STALLS.ANY	Counts all Register Allocation Table stall cycles due to: Cycles when ROB read port stalls occurred, which did not allow new micro-ops to enter the execution pipe. Cycles when partial register stalls occurred Cycles when flag stalls occurred Cycles floating-point unit (FPU) status word stalls occurred. To count each of these conditions separately use the events: RAT_STALLS.ROB_READ_PORT, RAT_STALLS.PARTIAL, RAT_STALLS.FLAGS, and RAT_STALLS.FPSW.	
D4H	01H	SEG_RENAME_STALLS	Counts the number of stall cycles due to the lack of renaming resources for the ES, DS, FS, and GS segment registers. If a segment is renamed but not retired and a second update to the same segment occurs, a stall occurs in the front-end of the pipeline until the renamed segment retires.	

**Table 19-7. Non-Architectural Performance Events In the Processor Core for Intel® Core™ i7 Processor and Intel® Xeon® Processor 5500 Series**

Event Num.	Umask Value	Event Mask Mnemonic	Description	Comment
D5H	01H	ES_REG_RENAMES	Counts the number of times the ES segment register is renamed.	
DBH	01H	UOP_UNFUSION	Counts unfusion events due to floating point exception to a fused uop.	
E0H	01H	BR_INST_DECODED	Counts the number of branch instructions decoded.	
E5H	01H	BPU_MISSED_CALL_RET	Counts number of times the Branch Prediction Unit missed predicting a call or return branch.	
E6H	01H	BACLEAR.CLEAR	Counts the number of times the front end is resteeered, mainly when the Branch Prediction Unit cannot provide a correct prediction and this is corrected by the Branch Address Calculator at the front end. This can occur if the code has many branches such that they cannot be consumed by the BPU. Each BACLEAR asserted by the BAC generates approximately an 8 cycle bubble in the instruction fetch pipeline. The effect on total execution time depends on the surrounding code.	
E6H	02H	BACLEAR.BAD_TARGET	Counts number of Branch Address Calculator clears (BACLEAR) asserted due to conditional branch instructions in which there was a target hit but the direction was wrong. Each BACLEAR asserted by the BAC generates approximately an 8 cycle bubble in the instruction fetch pipeline.	
E8H	01H	BPU_CLEAR.EARLY	Counts early (normal) Branch Prediction Unit clears: BPU predicted a taken branch after incorrectly assuming that it was not taken.	The BPU clear leads to 2 cycle bubble in the Front End.



**Table 19-7. Non-Architectural Performance Events In the Processor Core for Intel® Core™ i7 Processor and Intel® Xeon® Processor 5500 Series**

Event Num.	Umask Value	Event Mask Mnemonic	Description	Comment
E8H	02H	BPU_CLEAR.S.LATE	Counts late Branch Prediction Unit clears due to Most Recently Used conflicts. The PBU clear leads to a 3 cycle bubble in the Front End.	
FOH	01H	L2_TRANSACTION.S.LOAD	Counts L2 load operations due to HW prefetch or demand loads.	
FOH	02H	L2_TRANSACTION.S.RFO	Counts L2 RFO operations due to HW prefetch or demand RFOs.	
FOH	04H	L2_TRANSACTION.S.FETCH	Counts L2 instruction fetch operations due to HW prefetch or demand ifetch.	
FOH	08H	L2_TRANSACTION.S.PREFETCH	Counts L2 prefetch operations.	
FOH	10H	L2_TRANSACTION.S.L1D_WB	Counts L1D writeback operations to the L2.	
FOH	20H	L2_TRANSACTION.S.FILL	Counts L2 cache line fill operations due to load, RFO, L1D writeback or prefetch.	
FOH	40H	L2_TRANSACTION.S.WB	Counts L2 writeback operations to the L3.	
FOH	80H	L2_TRANSACTION.S.ANY	Counts all L2 cache operations.	
F1H	02H	L2_LINES_IN.S.STATE	Counts the number of cache lines allocated in the L2 cache in the S (shared) state.	
F1H	04H	L2_LINES_IN.E.STATE	Counts the number of cache lines allocated in the L2 cache in the E (exclusive) state.	
F1H	07H	L2_LINES_IN.ANY	Counts the number of cache lines allocated in the L2 cache.	
F2H	01H	L2_LINES_OUT.DEMAND_CLEAN	Counts L2 clean cache lines evicted by a demand request.	
F2H	02H	L2_LINES_OUT.DEMAND_DIRTY	Counts L2 dirty (modified) cache lines evicted by a demand request.	
F2H	04H	L2_LINES_OUT.PREFETCH_CLEAN	Counts L2 clean cache line evicted by a prefetch request.	

**Table 19-7. Non-Architectural Performance Events In the Processor Core for Intel® Core™ i7 Processor and Intel® Xeon® Processor 5500 Series**

Event Num.	Umask Value	Event Mask Mnemonic	Description	Comment
F2H	08H	L2_LINES_OUT.PREFETCH_DIRTY	Counts L2 modified cache line evicted by a prefetch request.	
F2H	0FH	L2_LINES_OUT.ANY	Counts all L2 cache lines evicted for any reason.	
F4H	10H	SQ_MISC.SPLIT_LOCK	Counts the number of SQ lock splits across a cache line.	
F6H	01H	SQ_FULL_STALL_CYCLES	Counts cycles the Super Queue is full. Neither of the threads on this core will be able to access the uncore.	
F7H	01H	FP_ASSIST.ALL	Counts the number of floating point operations executed that required micro-code assist intervention. Assists are required in the following cases: SSE instructions, (Denormal input when the DAZ flag is off or Underflow result when the FTZ flag is off); x87 instructions, (NaN or denormal are loaded to a register or used as input from memory, Division by 0 or Underflow output).	
F7H	02H	FP_ASSIST.OUTPUT	Counts number of floating point micro-code assist when the output value (destination register) is invalid.	
F7H	04H	FP_ASSIST.INPUT	Counts number of floating point micro-code assist when the input value (one of the source operands to an FP instruction) is invalid.	
FDH	01H	SIMD_INT_64.PACKED_MPY	Counts number of SIMD integer 64 bit packed multiply operations.	
FDH	02H	SIMD_INT_64.PACKED_SHIFT	Counts number of SIMD integer 64 bit packed shift operations.	
FDH	04H	SIMD_INT_64.PACK	Counts number of SIMD integer 64 bit pack operations.	
FDH	08H	SIMD_INT_64.UNPACK	Counts number of SIMD integer 64 bit unpack operations.	

**Table 19-7. Non-Architectural Performance Events In the Processor Core for Intel® Core™ i7 Processor and Intel® Xeon® Processor 5500 Series**

Event Num.	Umask Value	Event Mask Mnemonic	Description	Comment
FDH	10H	SIMD_INT_64.PACKED_LOGICAL	Counts number of SIMD integer 64 bit logical operations.	
FDH	20H	SIMD_INT_64.PACKED_ARITH	Counts number of SIMD integer 64 bit arithmetic operations.	
FDH	40H	SIMD_INT_64.SHUFFLE_MOVE	Counts number of SIMD integer 64 bit shift or move operations.	

Non-architectural Performance monitoring events that are located in the uncore subsystem are implementation specific between different platforms using processors based on Intel microarchitecture code name Nehalem. Processors with CPUID signature of DisplayFamily\_DisplayModel 06\_1AH, 06\_1EH, and 06\_1FH support performance events listed in Table 19-8.

**Table 19-8. Non-Architectural Performance Events In the Processor Uncore for Intel® Core™ i7 Processor and Intel® Xeon® Processor 5500 Series**

Event Num.	Umask Value	Event Mask Mnemonic	Description	Comment
00H	01H	UNC_GQ_CYCLES_FULL.READ_TRACKER	Uncore cycles Global Queue read tracker is full.	
00H	02H	UNC_GQ_CYCLES_FULL.WRITE_TRACKER	Uncore cycles Global Queue write tracker is full.	
00H	04H	UNC_GQ_CYCLES_FULL.PEER_PROBE_TRACKER	Uncore cycles Global Queue peer probe tracker is full. The peer probe tracker queue tracks snoops from the IOH and remote sockets.	
01H	01H	UNC_GQ_CYCLES_NOT_EMPTY.READ_TRACKER	Uncore cycles were Global Queue read tracker has at least one valid entry.	
01H	02H	UNC_GQ_CYCLES_NOT_EMPTY.WRITE_TRACKER	Uncore cycles were Global Queue write tracker has at least one valid entry.	
01H	04H	UNC_GQ_CYCLES_NOT_EMPTY.PEER_PROBE_TRACKER	Uncore cycles were Global Queue peer probe tracker has at least one valid entry. The peer probe tracker queue tracks IOH and remote socket snoops.	

**Table 19-8. Non-Architectural Performance Events In the Processor Uncore for Intel® Core™ i7 Processor and Intel® Xeon® Processor 5500 Series**

Event Num.	Umask Value	Event Mask Mnemonic	Description	Comment
03H	01H	UNC_GQ_ALLOC.REA D_TRACKER	Counts the number of tread tracker allocate to deallocate entries. The GQ read tracker allocate to deallocate occupancy count is divided by the count to obtain the average read tracker latency.	
03H	02H	UNC_GQ_ALLOC.RT_ L3_MISS	Counts the number GQ read tracker entries for which a full cache line read has missed the L3. The GQ read tracker L3 miss to fill occupancy count is divided by this count to obtain the average cache line read L3 miss latency. The latency represents the time after which the L3 has determined that the cache line has missed. The time between a GQ read tracker allocation and the L3 determining that the cache line has missed is the average L3 hit latency. The total L3 cache line read miss latency is the hit latency + L3 miss latency.	
03H	04H	UNC_GQ_ALLOC.RT_ TO_L3_RESP	Counts the number of GQ read tracker entries that are allocated in the read tracker queue that hit or miss the L3. The GQ read tracker L3 hit occupancy count is divided by this count to obtain the average L3 hit latency.	
03H	08H	UNC_GQ_ALLOC.RT_ TO_RTID_ACQUIRED	Counts the number of GQ read tracker entries that are allocated in the read tracker, have missed in the L3 and have not acquired a Request Transaction ID. The GQ read tracker L3 miss to RTID acquired occupancy count is divided by this count to obtain the average latency for a read L3 miss to acquire an RTID.	

**Table 19-8. Non-Architectural Performance Events In the Processor Uncore for Intel® Core™ i7 Processor and Intel® Xeon® Processor 5500 Series**

Event Num.	Umask Value	Event Mask Mnemonic	Description	Comment
03H	10H	UNC_GQ_ALLOC.WT_TO_RTID_ACQUIRED	Counts the number of GQ write tracker entries that are allocated in the write tracker, have missed in the L3 and have not acquired a Request Transaction ID. The GQ write tracker L3 miss to RTID occupancy count is divided by this count to obtain the average latency for a write L3 miss to acquire an RTID.	
03H	20H	UNC_GQ_ALLOC.WRITE_TRACKER	Counts the number of GQ write tracker entries that are allocated in the write tracker queue that miss the L3. The GQ write tracker occupancy count is divided by the this count to obtain the average L3 write miss latency.	
03H	40H	UNC_GQ_ALLOC.PEER_PROBE_TRACKER	Counts the number of GQ peer probe tracker (snoop) entries that are allocated in the peer probe tracker queue that miss the L3. The GQ peer probe occupancy count is divided by this count to obtain the average L3 peer probe miss latency.	
04H	01H	UNC_GQ_DATA.FROM_QPI	Cycles Global Queue Quickpath Interface input data port is busy importing data from the Quickpath Interface. Each cycle the input port can transfer 8 or 16 bytes of data.	
04H	02H	UNC_GQ_DATA.FROM_QMC	Cycles Global Queue Quickpath Memory Interface input data port is busy importing data from the Quickpath Memory Interface. Each cycle the input port can transfer 8 or 16 bytes of data.	
04H	04H	UNC_GQ_DATA.FROM_L3	Cycles GQ L3 input data port is busy importing data from the Last Level Cache. Each cycle the input port can transfer 32 bytes of data.	

**Table 19-8. Non-Architectural Performance Events In the Processor Uncore for Intel® Core™ i7 Processor and Intel® Xeon® Processor 5500 Series**

Event Num.	Umask Value	Event Mask Mnemonic	Description	Comment
04H	08H	UNC_GQ_DATA.FROM_CORES_02	Cycles GQ Core 0 and 2 input data port is busy importing data from processor cores 0 and 2. Each cycle the input port can transfer 32 bytes of data.	
04H	10H	UNC_GQ_DATA.FROM_CORES_13	Cycles GQ Core 1 and 3 input data port is busy importing data from processor cores 1 and 3. Each cycle the input port can transfer 32 bytes of data.	
05H	01H	UNC_GQ_DATA.TO_QPI_QMC	Cycles GQ QPI and QMC output data port is busy sending data to the Quickpath Interface or Quickpath Memory Interface. Each cycle the output port can transfer 32 bytes of data.	
05H	02H	UNC_GQ_DATA.TO_L3	Cycles GQ L3 output data port is busy sending data to the Last Level Cache. Each cycle the output port can transfer 32 bytes of data.	
05H	04H	UNC_GQ_DATA.TO_CORES	Cycles GQ Core output data port is busy sending data to the Cores. Each cycle the output port can transfer 32 bytes of data.	
06H	01H	UNC_SNP_RESP_TO_LOCAL_HOME.E_STATE	Number of snoop responses to the local home that L3 does not have the referenced cache line.	
06H	02H	UNC_SNP_RESP_TO_LOCAL_HOME.S_STATE	Number of snoop responses to the local home that L3 has the referenced line cached in the S state.	
06H	04H	UNC_SNP_RESP_TO_LOCAL_HOME.FWD_S_STATE	Number of responses to code or data read snoops to the local home that the L3 has the referenced cache line in the E state. The L3 cache line state is changed to the S state and the line is forwarded to the local home in the S state.	

**Table 19-8. Non-Architectural Performance Events In the Processor Uncore for Intel® Core™ i7 Processor and Intel® Xeon® Processor 5500 Series**

Event Num.	Umask Value	Event Mask Mnemonic	Description	Comment
06H	08H	UNC_SNP_RESP_TO_LOCAL_HOME.FWD_I_STATE	Number of responses to read invalidate snoops to the local home that the L3 has the referenced cache line in the M state. The L3 cache line state is invalidated and the line is forwarded to the local home in the M state.	
06H	10H	UNC_SNP_RESP_TO_LOCAL_HOME.CONFLICT	Number of conflict snoop responses sent to the local home.	
06H	20H	UNC_SNP_RESP_TO_LOCAL_HOME.WB	Number of responses to code or data read snoops to the local home that the L3 has the referenced line cached in the M state.	
07H	01H	UNC_SNP_RESP_TO_REMOTE_HOME.I_STATE	Number of snoop responses to a remote home that L3 does not have the referenced cache line.	
07H	02H	UNC_SNP_RESP_TO_REMOTE_HOME.S_STATE	Number of snoop responses to a remote home that L3 has the referenced line cached in the S state.	
07H	04H	UNC_SNP_RESP_TO_REMOTE_HOME.FWD_S_STATE	Number of responses to code or data read snoops to a remote home that the L3 has the referenced cache line in the E state. The L3 cache line state is changed to the S state and the line is forwarded to the remote home in the S state.	
07H	08H	UNC_SNP_RESP_TO_REMOTE_HOME.FWD_I_STATE	Number of responses to read invalidate snoops to a remote home that the L3 has the referenced cache line in the M state. The L3 cache line state is invalidated and the line is forwarded to the remote home in the M state.	
07H	10H	UNC_SNP_RESP_TO_REMOTE_HOME.CONFLICT	Number of conflict snoop responses sent to the local home.	

**Table 19-8. Non-Architectural Performance Events In the Processor Uncore for Intel® Core™ i7 Processor and Intel® Xeon® Processor 5500 Series**

Event Num.	Umask Value	Event Mask Mnemonic	Description	Comment
07H	20H	UNC_SNP_RESP_TO_REMOTE_HOME.WB	Number of responses to code or data read snoops to a remote home that the L3 has the referenced line cached in the M state.	
07H	24H	UNC_SNP_RESP_TO_REMOTE_HOME.HITM	Number of HITM snoop responses to a remote home	
08H	01H	UNC_L3_HITS.READ	Number of code read, data read and RFO requests that hit in the L3	
08H	02H	UNC_L3_HITS.WRITE	Number of writeback requests that hit in the L3. Writebacks from the cores will always result in L3 hits due to the inclusive property of the L3.	
08H	04H	UNC_L3_HITS.PROBE	Number of snoops from IOH or remote sockets that hit in the L3.	
08H	03H	UNC_L3_HITS.ANY	Number of reads and writes that hit the L3.	
09H	01H	UNC_L3_MISS.READ	Number of code read, data read and RFO requests that miss the L3.	
09H	02H	UNC_L3_MISS.WRITE	Number of writeback requests that miss the L3. Should always be zero as writebacks from the cores will always result in L3 hits due to the inclusive property of the L3.	
09H	04H	UNC_L3_MISS.PROBE	Number of snoops from IOH or remote sockets that miss the L3.	
09H	03H	UNC_L3_MISS.ANY	Number of reads and writes that miss the L3.	
0AH	01H	UNC_L3_LINES_IN.M_STATE	Counts the number of L3 lines allocated in M state. The only time a cache line is allocated in the M state is when the line was forwarded in M state is forwarded due to a Snoop Read Invalidate Own request.	
0AH	02H	UNC_L3_LINES_IN.E_STATE	Counts the number of L3 lines allocated in E state.	
0AH	04H	UNC_L3_LINES_IN.S_STATE	Counts the number of L3 lines allocated in S state.	



**Table 19-8. Non-Architectural Performance Events In the Processor Uncore for Intel® Core™ i7 Processor and Intel® Xeon® Processor 5500 Series**

Event Num.	Umask Value	Event Mask Mnemonic	Description	Comment
0AH	08H	UNC_L3_LINES_IN.F_STATE	Counts the number of L3 lines allocated in F state.	
0AH	0FH	UNC_L3_LINES_IN.ANY	Counts the number of L3 lines allocated in any state.	
0BH	01H	UNC_L3_LINES_OUT.M_STATE	Counts the number of L3 lines victimized that were in the M state. When the victim cache line is in M state, the line is written to its home cache agent which can be either local or remote.	
0BH	02H	UNC_L3_LINES_OUT.E_STATE	Counts the number of L3 lines victimized that were in the E state.	
0BH	04H	UNC_L3_LINES_OUT.S_STATE	Counts the number of L3 lines victimized that were in the S state.	
0BH	08H	UNC_L3_LINES_OUT.I_STATE	Counts the number of L3 lines victimized that were in the I state.	
0BH	10H	UNC_L3_LINES_OUT.F_STATE	Counts the number of L3 lines victimized that were in the F state.	
0BH	1FH	UNC_L3_LINES_OUT.ANY	Counts the number of L3 lines victimized in any state.	
20H	01H	UNC_QHL_REQUEST S.IOH_READS	Counts number of Quickpath Home Logic read requests from the IOH.	
20H	02H	UNC_QHL_REQUEST S.IOH_WRITES	Counts number of Quickpath Home Logic write requests from the IOH.	
20H	04H	UNC_QHL_REQUEST S.REMOTE_READS	Counts number of Quickpath Home Logic read requests from a remote socket.	
20H	08H	UNC_QHL_REQUEST S.REMOTE_WRITES	Counts number of Quickpath Home Logic write requests from a remote socket.	
20H	10H	UNC_QHL_REQUEST S.LOCAL_READS	Counts number of Quickpath Home Logic read requests from the local socket.	
20H	20H	UNC_QHL_REQUEST S.LOCAL_WRITES	Counts number of Quickpath Home Logic write requests from the local socket.	

**Table 19-8. Non-Architectural Performance Events In the Processor Uncore for Intel® Core™ i7 Processor and Intel® Xeon® Processor 5500 Series**

Event Num.	Umask Value	Event Mask Mnemonic	Description	Comment
21H	01H	UNC_QHL_CYCLES_FULL.IOH	Counts uclk cycles all entries in the Quickpath Home Logic IOH are full.	
21H	02H	UNC_QHL_CYCLES_FULL.REMOTE	Counts uclk cycles all entries in the Quickpath Home Logic remote tracker are full.	
21H	04H	UNC_QHL_CYCLES_FULL.LOCAL	Counts uclk cycles all entries in the Quickpath Home Logic local tracker are full.	
22H	01H	UNC_QHL_CYCLES_NOT_EMPTY.IOH	Counts uclk cycles all entries in the Quickpath Home Logic IOH is busy.	
22H	02H	UNC_QHL_CYCLES_NOT_EMPTY.REMOTE	Counts uclk cycles all entries in the Quickpath Home Logic remote tracker is busy.	
22H	04H	UNC_QHL_CYCLES_NOT_EMPTY.LOCAL	Counts uclk cycles all entries in the Quickpath Home Logic local tracker is busy.	
23H	01H	UNC_QHL_OCCUPANCY.IOH	QHL IOH tracker allocate to deallocate read occupancy.	
23H	02H	UNC_QHL_OCCUPANCY.REMOTE	QHL remote tracker allocate to deallocate read occupancy.	
23H	04H	UNC_QHL_OCCUPANCY.LOCAL	QHL local tracker allocate to deallocate read occupancy.	
24H	02H	UNC_QHL_ADDRESS_CONFLICTS.2WAY	Counts number of QHL Active Address Table (AAT) entries that saw a max of 2 conflicts. The AAT is a structure that tracks requests that are in conflict. The requests themselves are in the home tracker entries. The count is reported when an AAT entry deallocates.	
24H	04H	UNC_QHL_ADDRESS_CONFLICTS.3WAY	Counts number of QHL Active Address Table (AAT) entries that saw a max of 3 conflicts. The AAT is a structure that tracks requests that are in conflict. The requests themselves are in the home tracker entries. The count is reported when an AAT entry deallocates.	

**Table 19-8. Non-Architectural Performance Events In the Processor Uncore for Intel® Core™ i7 Processor and Intel® Xeon® Processor 5500 Series**

Event Num.	Umask Value	Event Mask Mnemonic	Description	Comment
25H	01H	UNC_QHL_CONFLICT_CYCLES.IOH	Counts cycles the Quickpath Home Logic IOH Tracker contains two or more requests with an address conflict. A max of 3 requests can be in conflict.	
25H	02H	UNC_QHL_CONFLICT_CYCLES.REMOTE	Counts cycles the Quickpath Home Logic Remote Tracker contains two or more requests with an address conflict. A max of 3 requests can be in conflict.	
25H	04H	UNC_QHL_CONFLICT_CYCLES.LOCAL	Counts cycles the Quickpath Home Logic Local Tracker contains two or more requests with an address conflict. A max of 3 requests can be in conflict.	
26H	01H	UNC_QHL_TO_QMC_BYPASS	Counts number or requests to the Quickpath Memory Controller that bypass the Quickpath Home Logic. All local accesses can be bypassed. For remote requests, only read requests can be bypassed.	
27H	01H	UNC_QMC_NORMAL_FULL.READ.CH0	Uncore cycles all the entries in the DRAM channel 0 medium or low priority queue are occupied with read requests.	
27H	02H	UNC_QMC_NORMAL_FULL.READ.CH1	Uncore cycles all the entries in the DRAM channel 1 medium or low priority queue are occupied with read requests.	
27H	04H	UNC_QMC_NORMAL_FULL.READ.CH2	Uncore cycles all the entries in the DRAM channel 2 medium or low priority queue are occupied with read requests.	
27H	08H	UNC_QMC_NORMAL_FULL.WRITE.CH0	Uncore cycles all the entries in the DRAM channel 0 medium or low priority queue are occupied with write requests.	

**Table 19-8. Non-Architectural Performance Events In the Processor Uncore for Intel® Core™ i7 Processor and Intel® Xeon® Processor 5500 Series**

Event Num.	Umask Value	Event Mask Mnemonic	Description	Comment
27H	10H	UNC_QMC_NORMAL_FULL.WRITE.CH1	Counts cycles all the entries in the DRAM channel 1 medium or low priority queue are occupied with write requests.	
27H	20H	UNC_QMC_NORMAL_FULL.WRITE.CH2	Uncore cycles all the entries in the DRAM channel 2 medium or low priority queue are occupied with write requests.	
28H	01H	UNC_QMC_ISOC_FULL.READ.CH0	Counts cycles all the entries in the DRAM channel 0 high priority queue are occupied with isochronous read requests.	
28H	02H	UNC_QMC_ISOC_FULL.READ.CH1	Counts cycles all the entries in the DRAM channel 1 high priority queue are occupied with isochronous read requests.	
28H	04H	UNC_QMC_ISOC_FULL.READ.CH2	Counts cycles all the entries in the DRAM channel 2 high priority queue are occupied with isochronous read requests.	
28H	08H	UNC_QMC_ISOC_FULL.WRITE.CH0	Counts cycles all the entries in the DRAM channel 0 high priority queue are occupied with isochronous write requests.	
28H	10H	UNC_QMC_ISOC_FULL.WRITE.CH1	Counts cycles all the entries in the DRAM channel 1 high priority queue are occupied with isochronous write requests.	
28H	20H	UNC_QMC_ISOC_FULL.WRITE.CH2	Counts cycles all the entries in the DRAM channel 2 high priority queue are occupied with isochronous write requests.	
29H	01H	UNC_QMC_BUSY.READ.CH0	Counts cycles where Quickpath Memory Controller has at least 1 outstanding read request to DRAM channel 0.	

**Table 19-8. Non-Architectural Performance Events In the Processor Uncore for Intel® Core™ i7 Processor and Intel® Xeon® Processor 5500 Series**

Event Num.	Umask Value	Event Mask Mnemonic	Description	Comment
29H	02H	UNC_QMC_BUSY.READ.CH1	Counts cycles where Quickpath Memory Controller has at least 1 outstanding read request to DRAM channel 1.	
29H	04H	UNC_QMC_BUSY.READ.CH2	Counts cycles where Quickpath Memory Controller has at least 1 outstanding read request to DRAM channel 2.	
29H	08H	UNC_QMC_BUSY.WRITE.CH0	Counts cycles where Quickpath Memory Controller has at least 1 outstanding write request to DRAM channel 0.	
29H	10H	UNC_QMC_BUSY.WRITE.CH1	Counts cycles where Quickpath Memory Controller has at least 1 outstanding write request to DRAM channel 1.	
29H	20H	UNC_QMC_BUSY.WRITE.CH2	Counts cycles where Quickpath Memory Controller has at least 1 outstanding write request to DRAM channel 2.	
2AH	01H	UNC_QMC_OCCUPANCY.CH0	IMC channel 0 normal read request occupancy.	
2AH	02H	UNC_QMC_OCCUPANCY.CH1	IMC channel 1 normal read request occupancy.	
2AH	04H	UNC_QMC_OCCUPANCY.CH2	IMC channel 2 normal read request occupancy.	
2BH	01H	UNC_QMC_ISSOC_OCCUPANCY.CH0	IMC channel 0 issoc read request occupancy.	
2BH	02H	UNC_QMC_ISSOC_OCCUPANCY.CH1	IMC channel 1 issoc read request occupancy.	
2BH	04H	UNC_QMC_ISSOC_OCCUPANCY.CH2	IMC channel 2 issoc read request occupancy.	
2BH	07H	UNC_QMC_ISSOC_READS.ANY	IMC issoc read request occupancy.	

**Table 19-8. Non-Architectural Performance Events In the Processor Uncore for Intel® Core™ i7 Processor and Intel® Xeon® Processor 5500 Series**

Event Num.	Umask Value	Event Mask Mnemonic	Description	Comment
2CH	01H	UNC_QMC_NORMAL_READS.CHO	Counts the number of Quickpath Memory Controller channel 0 medium and low priority read requests. The QMC channel 0 normal read occupancy divided by this count provides the average QMC channel 0 read latency.	
2CH	02H	UNC_QMC_NORMAL_READS.CH1	Counts the number of Quickpath Memory Controller channel 1 medium and low priority read requests. The QMC channel 1 normal read occupancy divided by this count provides the average QMC channel 1 read latency.	
2CH	04H	UNC_QMC_NORMAL_READS.CH2	Counts the number of Quickpath Memory Controller channel 2 medium and low priority read requests. The QMC channel 2 normal read occupancy divided by this count provides the average QMC channel 2 read latency.	
2CH	07H	UNC_QMC_NORMAL_READS.ANY	Counts the number of Quickpath Memory Controller medium and low priority read requests. The QMC normal read occupancy divided by this count provides the average QMC read latency.	
2DH	01H	UNC_QMC_HIGH_PRIORITY_READS.CHO	Counts the number of Quickpath Memory Controller channel 0 high priority isochronous read requests.	
2DH	02H	UNC_QMC_HIGH_PRIORITY_READS.CH1	Counts the number of Quickpath Memory Controller channel 1 high priority isochronous read requests.	
2DH	04H	UNC_QMC_HIGH_PRIORITY_READS.CH2	Counts the number of Quickpath Memory Controller channel 2 high priority isochronous read requests.	
2DH	07H	UNC_QMC_HIGH_PRIORITY_READS.ANY	Counts the number of Quickpath Memory Controller high priority isochronous read requests.	

**Table 19-8. Non-Architectural Performance Events In the Processor Uncore for Intel® Core™ i7 Processor and Intel® Xeon® Processor 5500 Series**

Event Num.	Umask Value	Event Mask Mnemonic	Description	Comment
2EH	01H	UNC_QMC_CRITICAL_PRIORITY_READS.CH0	Counts the number of Quickpath Memory Controller channel 0 critical priority isochronous read requests.	
2EH	02H	UNC_QMC_CRITICAL_PRIORITY_READS.CH1	Counts the number of Quickpath Memory Controller channel 1 critical priority isochronous read requests.	
2EH	04H	UNC_QMC_CRITICAL_PRIORITY_READS.CH2	Counts the number of Quickpath Memory Controller channel 2 critical priority isochronous read requests.	
2EH	07H	UNC_QMC_CRITICAL_PRIORITY_READS.ANY	Counts the number of Quickpath Memory Controller critical priority isochronous read requests.	
2FH	01H	UNC_QMC_WRITES.FULL.CH0	Counts number of full cache line writes to DRAM channel 0.	
2FH	02H	UNC_QMC_WRITES.FULL.CH1	Counts number of full cache line writes to DRAM channel 1.	
2FH	04H	UNC_QMC_WRITES.FULL.CH2	Counts number of full cache line writes to DRAM channel 2.	
2FH	07H	UNC_QMC_WRITES.FULL.ANY	Counts number of full cache line writes to DRAM.	
2FH	08H	UNC_QMC_WRITES.PARTIAL.CH0	Counts number of partial cache line writes to DRAM channel 0.	
2FH	10H	UNC_QMC_WRITES.PARTIAL.CH1	Counts number of partial cache line writes to DRAM channel 1.	
2FH	20H	UNC_QMC_WRITES.PARTIAL.CH2	Counts number of partial cache line writes to DRAM channel 2.	
2FH	38H	UNC_QMC_WRITES.PARTIAL.ANY	Counts number of partial cache line writes to DRAM.	
30H	01H	UNC_QMC_CANCEL.CH0	Counts number of DRAM channel 0 cancel requests.	
30H	02H	UNC_QMC_CANCEL.CH1	Counts number of DRAM channel 1 cancel requests.	
30H	04H	UNC_QMC_CANCEL.CH2	Counts number of DRAM channel 2 cancel requests.	
30H	07H	UNC_QMC_CANCEL.ANY	Counts number of DRAM cancel requests.	

**Table 19-8. Non-Architectural Performance Events In the Processor Uncore for Intel® Core™ i7 Processor and Intel® Xeon® Processor 5500 Series**

Event Num.	Umask Value	Event Mask Mnemonic	Description	Comment
31H	01H	UNC_QMC_PRIORITY_UPDATES.CHO	Counts number of DRAM channel 0 priority updates. A priority update occurs when an ISOC high or critical request is received by the QHL and there is a matching request with normal priority that has already been issued to the QMC. In this instance, the QHL will send a priority update to QMC to expedite the request.	
31H	02H	UNC_QMC_PRIORITY_UPDATES.CH1	Counts number of DRAM channel 1 priority updates. A priority update occurs when an ISOC high or critical request is received by the QHL and there is a matching request with normal priority that has already been issued to the QMC. In this instance, the QHL will send a priority update to QMC to expedite the request.	
31H	04H	UNC_QMC_PRIORITY_UPDATES.CH2	Counts number of DRAM channel 2 priority updates. A priority update occurs when an ISOC high or critical request is received by the QHL and there is a matching request with normal priority that has already been issued to the QMC. In this instance, the QHL will send a priority update to QMC to expedite the request.	
31H	07H	UNC_QMC_PRIORITY_UPDATES.ANY	Counts number of DRAM priority updates. A priority update occurs when an ISOC high or critical request is received by the QHL and there is a matching request with normal priority that has already been issued to the QMC. In this instance, the QHL will send a priority update to QMC to expedite the request.	
33H	04H	UNC_QHL_FRC_ACK_CNFLTS.LOCAL	Counts number of Force Acknowledge Conflict messages sent by the Quickpath Home Logic to the local home.	



**Table 19-8. Non-Architectural Performance Events In the Processor Uncore for Intel® Core™ i7 Processor and Intel® Xeon® Processor 5500 Series**

Event Num.	Umask Value	Event Mask Mnemonic	Description	Comment
40H	01H	UNC_QPI_TX_STALL ED_SINGLE_FLIT.HO ME.LINK_0	Counts cycles the Quickpath outbound link 0 HOME virtual channel is stalled due to lack of a VNA and VNO credit. Note that this event does not filter out when a flit would not have been selected for arbitration because another virtual channel is getting arbitrated.	
40H	02H	UNC_QPI_TX_STALL ED_SINGLE_FLIT.SNO OP.LINK_0	Counts cycles the Quickpath outbound link 0 SNOOP virtual channel is stalled due to lack of a VNA and VNO credit. Note that this event does not filter out when a flit would not have been selected for arbitration because another virtual channel is getting arbitrated.	
40H	04H	UNC_QPI_TX_STALL ED_SINGLE_FLIT.NDR .LINK_0	Counts cycles the Quickpath outbound link 0 non-data response virtual channel is stalled due to lack of a VNA and VNO credit. Note that this event does not filter out when a flit would not have been selected for arbitration because another virtual channel is getting arbitrated.	
40H	08H	UNC_QPI_TX_STALL ED_SINGLE_FLIT.HO ME.LINK_1	Counts cycles the Quickpath outbound link 1 HOME virtual channel is stalled due to lack of a VNA and VNO credit. Note that this event does not filter out when a flit would not have been selected for arbitration because another virtual channel is getting arbitrated.	
40H	10H	UNC_QPI_TX_STALL ED_SINGLE_FLIT.SNO OP.LINK_1	Counts cycles the Quickpath outbound link 1 SNOOP virtual channel is stalled due to lack of a VNA and VNO credit. Note that this event does not filter out when a flit would not have been selected for arbitration because another virtual channel is getting arbitrated.	

**Table 19-8. Non-Architectural Performance Events In the Processor Uncore for Intel® Core™ i7 Processor and Intel® Xeon® Processor 5500 Series**

Event Num.	Umask Value	Event Mask Mnemonic	Description	Comment
40H	20H	UNC_QPI_TX_STALL ED_SINGLE_FLIT.NDR. LINK_1	Counts cycles the Quickpath outbound link 1 non-data response virtual channel is stalled due to lack of a VNA and VNO credit. Note that this event does not filter out when a flit would not have been selected for arbitration because another virtual channel is getting arbitrated.	
40H	07H	UNC_QPI_TX_STALL ED_SINGLE_FLIT.LIN K_0	Counts cycles the Quickpath outbound link 0 virtual channels are stalled due to lack of a VNA and VNO credit. Note that this event does not filter out when a flit would not have been selected for arbitration because another virtual channel is getting arbitrated.	
40H	38H	UNC_QPI_TX_STALL ED_SINGLE_FLIT.LIN K_1	Counts cycles the Quickpath outbound link 1 virtual channels are stalled due to lack of a VNA and VNO credit. Note that this event does not filter out when a flit would not have been selected for arbitration because another virtual channel is getting arbitrated.	
41H	01H	UNC_QPI_TX_STALL ED_MULTI_FLIT.DRS. LINK_0	Counts cycles the Quickpath outbound link 0 Data ResponSe virtual channel is stalled due to lack of VNA and VNO credits. Note that this event does not filter out when a flit would not have been selected for arbitration because another virtual channel is getting arbitrated.	
41H	02H	UNC_QPI_TX_STALL ED_MULTI_FLIT.NCB. LINK_0	Counts cycles the Quickpath outbound link 0 Non-Coherent Bypass virtual channel is stalled due to lack of VNA and VNO credits. Note that this event does not filter out when a flit would not have been selected for arbitration because another virtual channel is getting arbitrated.	

**Table 19-8. Non-Architectural Performance Events In the Processor Uncore for Intel® Core™ i7 Processor and Intel® Xeon® Processor 5500 Series**

Event Num.	Umask Value	Event Mask Mnemonic	Description	Comment
41H	04H	UNC_QPI_TX_STALL ED_MULTI_FLIT.NCS. LINK_0	Counts cycles the Quickpath outbound link 0 Non-Coherent Standard virtual channel is stalled due to lack of VNA and VNO credits. Note that this event does not filter out when a flit would not have been selected for arbitration because another virtual channel is getting arbitrated.	
41H	08H	UNC_QPI_TX_STALL ED_MULTI_FLIT.DRS. LINK_1	Counts cycles the Quickpath outbound link 1 Data ResponSe virtual channel is stalled due to lack of VNA and VNO credits. Note that this event does not filter out when a flit would not have been selected for arbitration because another virtual channel is getting arbitrated.	
41H	10H	UNC_QPI_TX_STALL ED_MULTI_FLIT.NCB. LINK_1	Counts cycles the Quickpath outbound link 1 Non-Coherent Bypass virtual channel is stalled due to lack of VNA and VNO credits. Note that this event does not filter out when a flit would not have been selected for arbitration because another virtual channel is getting arbitrated.	
41H	20H	UNC_QPI_TX_STALL ED_MULTI_FLIT.NCS. LINK_1	Counts cycles the Quickpath outbound link 1 Non-Coherent Standard virtual channel is stalled due to lack of VNA and VNO credits. Note that this event does not filter out when a flit would not have been selected for arbitration because another virtual channel is getting arbitrated.	
41H	07H	UNC_QPI_TX_STALL ED_MULTI_FLIT.LINK _0	Counts cycles the Quickpath outbound link 0 virtual channels are stalled due to lack of VNA and VNO credits. Note that this event does not filter out when a flit would not have been selected for arbitration because another virtual channel is getting arbitrated.	

**Table 19-8. Non-Architectural Performance Events In the Processor Uncore for Intel® Core™ i7 Processor and Intel® Xeon® Processor 5500 Series**

Event Num.	Umask Value	Event Mask Mnemonic	Description	Comment
41H	38H	UNC_QPI_TX_STALL ED_MULTI_FLIT.LINK_1	Counts cycles the Quickpath outbound link 1 virtual channels are stalled due to lack of VNA and VNO credits. Note that this event does not filter out when a flit would not have been selected for arbitration because another virtual channel is getting arbitrated.	
42H	02H	UNC_QPI_TX_HEADE R.BUSY.LINK_0	Number of cycles that the header buffer in the Quickpath Interface outbound link 0 is busy.	
42H	08H	UNC_QPI_TX_HEADE R.BUSY.LINK_1	Number of cycles that the header buffer in the Quickpath Interface outbound link 1 is busy.	
43H	01H	UNC_QPI_RX_NO_PP T_CREDIT.STALLS.LIN K_0	Number of cycles that snoop packets incoming to the Quickpath Interface link 0 are stalled and not sent to the GQ because the GQ Peer Probe Tracker (PPT) does not have any available entries.	
43H	02H	UNC_QPI_RX_NO_PP T_CREDIT.STALLS.LIN K_1	Number of cycles that snoop packets incoming to the Quickpath Interface link 1 are stalled and not sent to the GQ because the GQ Peer Probe Tracker (PPT) does not have any available entries.	
60H	01H	UNC_DRAM_OPEN.C H0	Counts number of DRAM Channel 0 open commands issued either for read or write. To read or write data, the referenced DRAM page must first be opened.	
60H	02H	UNC_DRAM_OPEN.C H1	Counts number of DRAM Channel 1 open commands issued either for read or write. To read or write data, the referenced DRAM page must first be opened.	

**Table 19-8. Non-Architectural Performance Events In the Processor Uncore for Intel® Core™ i7 Processor and Intel® Xeon® Processor 5500 Series**

Event Num.	Umask Value	Event Mask Mnemonic	Description	Comment
60H	04H	UNC_DRAM_OPEN.C H2	Counts number of DRAM Channel 2 open commands issued either for read or write. To read or write data, the referenced DRAM page must first be opened.	
61H	01H	UNC_DRAM_PAGE_C LOSE.CH0	DRAM channel 0 command issued to CLOSE a page due to page idle timer expiration. Closing a page is done by issuing a precharge.	
61H	02H	UNC_DRAM_PAGE_C LOSE.CH1	DRAM channel 1 command issued to CLOSE a page due to page idle timer expiration. Closing a page is done by issuing a precharge.	
61H	04H	UNC_DRAM_PAGE_C LOSE.CH2	DRAM channel 2 command issued to CLOSE a page due to page idle timer expiration. Closing a page is done by issuing a precharge.	
62H	01H	UNC_DRAM_PAGE_M ISS.CH0	Counts the number of precharges (PRE) that were issued to DRAM channel 0 because there was a page miss. A page miss refers to a situation in which a page is currently open and another page from the same bank needs to be opened. The new page experiences a page miss. Closing of the old page is done by issuing a precharge.	
62H	02H	UNC_DRAM_PAGE_M ISS.CH1	Counts the number of precharges (PRE) that were issued to DRAM channel 1 because there was a page miss. A page miss refers to a situation in which a page is currently open and another page from the same bank needs to be opened. The new page experiences a page miss. Closing of the old page is done by issuing a precharge.	

**Table 19-8. Non-Architectural Performance Events In the Processor Uncore for Intel® Core™ i7 Processor and Intel® Xeon® Processor 5500 Series**

Event Num.	Umask Value	Event Mask Mnemonic	Description	Comment
62H	04H	UNC_DRAM_PAGE_MISS.CH2	Counts the number of precharges (PRE) that were issued to DRAM channel 2 because there was a page miss. A page miss refers to a situation in which a page is currently open and another page from the same bank needs to be opened. The new page experiences a page miss. Closing of the old page is done by issuing a precharge.	
63H	01H	UNC_DRAM_READ_CAS.CH0	Counts the number of times a read CAS command was issued on DRAM channel 0.	
63H	02H	UNC_DRAM_READ_CAS.AUTOPRE_CH0	Counts the number of times a read CAS command was issued on DRAM channel 0 where the command issued used the auto-precharge (auto page close) mode.	
63H	04H	UNC_DRAM_READ_CAS.CH1	Counts the number of times a read CAS command was issued on DRAM channel 1.	
63H	08H	UNC_DRAM_READ_CAS.AUTOPRE_CH1	Counts the number of times a read CAS command was issued on DRAM channel 1 where the command issued used the auto-precharge (auto page close) mode.	
63H	10H	UNC_DRAM_READ_CAS.CH2	Counts the number of times a read CAS command was issued on DRAM channel 2.	
63H	20H	UNC_DRAM_READ_CAS.AUTOPRE_CH2	Counts the number of times a read CAS command was issued on DRAM channel 2 where the command issued used the auto-precharge (auto page close) mode.	
64H	01H	UNC_DRAM_WRITE_CAS.CH0	Counts the number of times a write CAS command was issued on DRAM channel 0.	

**Table 19-8. Non-Architectural Performance Events In the Processor Uncore for Intel® Core™ i7 Processor and Intel® Xeon® Processor 5500 Series**

Event Num.	Umask Value	Event Mask Mnemonic	Description	Comment
64H	02H	UNC_DRAM_WRITE_CAS.AUTOPRE_CH0	Counts the number of times a write CAS command was issued on DRAM channel 0 where the command issued used the auto-precharge (auto page close) mode.	
64H	04H	UNC_DRAM_WRITE_CAS.CH1	Counts the number of times a write CAS command was issued on DRAM channel 1.	
64H	08H	UNC_DRAM_WRITE_CAS.AUTOPRE_CH1	Counts the number of times a write CAS command was issued on DRAM channel 1 where the command issued used the auto-precharge (auto page close) mode.	
64H	10H	UNC_DRAM_WRITE_CAS.CH2	Counts the number of times a write CAS command was issued on DRAM channel 2.	
64H	20H	UNC_DRAM_WRITE_CAS.AUTOPRE_CH2	Counts the number of times a write CAS command was issued on DRAM channel 2 where the command issued used the auto-precharge (auto page close) mode.	
65H	01H	UNC_DRAM_REFRES H.CH0	Counts number of DRAM channel 0 refresh commands. DRAM loses data content over time. In order to keep correct data content, the data values have to be refreshed periodically.	
65H	02H	UNC_DRAM_REFRES H.CH1	Counts number of DRAM channel 1 refresh commands. DRAM loses data content over time. In order to keep correct data content, the data values have to be refreshed periodically.	
65H	04H	UNC_DRAM_REFRES H.CH2	Counts number of DRAM channel 2 refresh commands. DRAM loses data content over time. In order to keep correct data content, the data values have to be refreshed periodically.	

**Table 19-8. Non-Architectural Performance Events In the Processor Uncore for Intel® Core™ i7 Processor and Intel® Xeon® Processor 5500 Series**

Event Num.	Umask Value	Event Mask Mnemonic	Description	Comment
66H	01H	UNC_DRAM_PRE_AL L.CH0	Counts number of DRAM Channel 0 precharge-all (PREALL) commands that close all open pages in a rank. PREALL is issued when the DRAM needs to be refreshed or needs to go into a power down mode.	
66H	02H	UNC_DRAM_PRE_AL L.CH1	Counts number of DRAM Channel 1 precharge-all (PREALL) commands that close all open pages in a rank. PREALL is issued when the DRAM needs to be refreshed or needs to go into a power down mode.	
66H	04H	UNC_DRAM_PRE_AL L.CH2	Counts number of DRAM Channel 2 precharge-all (PREALL) commands that close all open pages in a rank. PREALL is issued when the DRAM needs to be refreshed or needs to go into a power down mode.	

Intel Xeon processors with CPUID signature of DisplayFamily\_DisplayModel 06\_2EH have a distinct uncore sub-system that is significantly different from the uncore found in processors with CPUID signature 06\_1AH, 06\_1EH, and 06\_1FH. Non-architectural Performance monitoring events for its uncore will be available in future documentation.

## 19.5 PERFORMANCE MONITORING EVENTS FOR PROCESSORS BASED ON INTEL® MICROARCHITECTURE CODE NAME WESTMERE

Intel 64 processors based on Intel® microarchitecture code name Westmere support the architectural and non-architectural performance-monitoring events listed in Table 19-1 and Table 19-9. Table 19-9 applies to processors with CPUID signature of DisplayFamily\_DisplayModel encoding with the following values: 06\_25H, 06\_2CH. In addition, these processors (CPUID signature of DisplayFamily\_DisplayModel 06\_25H, 06\_2CH) also support the following non-architectural, product-specific uncore performance-monitoring events listed in Table 19-10. Fixed counters support the architecture events defined in Table 19-12.



**Table 19-9. Non-Architectural Performance Events In the Processor Core for Processors Based on Intel® Microarchitecture Code Name Westmere**

Event Num.	Umask Value	Event Mask Mnemonic	Description	Comment
03H	02H	LOAD_BLOCK.OVERLAP_STORE	Loads that partially overlap an earlier store.	
04H	07H	SB_DRAIN.ANY	All Store buffer stall cycles.	
05H	02H	MISALIGN_MEMORY.STORE	All store referenced with misaligned address.	
06H	04H	STORE_BLOCKS.AT_RET	Counts number of loads delayed with at-Retirement block code. The following loads need to be executed at retirement and wait for all senior stores on the same thread to be drained: load splitting across 4K boundary (page split), load accessing uncacheable (UC or USWC) memory, load lock, and load with page table in UC or USWC memory region.	
06H	08H	STORE_BLOCKS.L1D_BLOCK	Cacheable loads delayed with L1D block code.	
07H	01H	PARTIAL_ADDRESS_ALIAS	Counts false dependency due to partial address aliasing.	
08H	01H	DTLB_LOAD_MISSES.ANY	Counts all load misses that cause a page walk.	
08H	02H	DTLB_LOAD_MISSES.WALK_COMPLETED	Counts number of completed page walks due to load miss in the STLB.	
08H	04H	DTLB_LOAD_MISSES.WALK_CYCLES	Cycles PMH is busy with a page walk due to a load miss in the STLB.	
08H	10H	DTLB_LOAD_MISSES.STLB_HIT	Number of cache load STLB hits.	
08H	20H	DTLB_LOAD_MISSES.PDE_MISS	Number of DTLB cache load misses where the low part of the linear to physical address translation was missed.	
0BH	01H	MEM_INST_RETIRED.LOADS	Counts the number of instructions with an architecturally-visible load retired on the architected path.	
0BH	02H	MEM_INST_RETIRED.STORES	Counts the number of instructions with an architecturally-visible store retired on the architected path.	

**Table 19-9. Non-Architectural Performance Events In the Processor Core for Processors Based on Intel® Microarchitecture Code Name Westmere**

Event Num.	Umask Value	Event Mask Mnemonic	Description	Comment
OBH	10H	MEM_INST_RETIRED.LATENCY_ABOVE_THRESHOLD	Counts the number of instructions exceeding the latency specified with Id_lat facility.	In conjunction with Id_lat facility
OCH	01H	MEM_STORE_RETIRED.DTLB_MISS	The event counts the number of retired stores that missed the DTLB. The DTLB miss is not counted if the store operation causes a fault. Does not counter prefetches. Counts both primary and secondary misses to the TLB.	
OEH	01H	UOPS_ISSUED.ANY	Counts the number of Uops issued by the Register Allocation Table to the Reservation Station, i.e. the UOPs issued from the front end to the back end.	
OEH	01H	UOPS_ISSUED.STALLED_CYCLES	Counts the number of cycles no Uops issued by the Register Allocation Table to the Reservation Station, i.e. the UOPs issued from the front end to the back end.	set "invert=1, cmask = 1"
OEH	02H	UOPS_ISSUED.FUSED	Counts the number of fused Uops that were issued from the Register Allocation Table to the Reservation Station.	
OFH	01H	MEM_UNCORE_RETIRED.UNKNOWN_SOURCE	Load instructions retired with unknown LLC miss (Precise Event).	Applicable to one and two sockets
OFH	02H	MEM_UNCORE_RETIRED.OTHER_CORE_L2_HIT	Load instructions retired that HIT modified data in sibling core (Precise Event).	Applicable to one and two sockets
OFH	04H	MEM_UNCORE_RETIRED.REMOTE_HITM	Load instructions retired that HIT modified data in remote socket (Precise Event).	Applicable to two sockets only
OFH	08H	MEM_UNCORE_RETIRED.LOCAL_DRAM_AND_REMOTE_CACHE_HIT	Load instructions retired local dram and remote cache HIT data sources (Precise Event).	Applicable to one and two sockets

**Table 19-9. Non-Architectural Performance Events In the Processor Core for Processors Based on Intel® Microarchitecture Code Name Westmere**

Event Num.	Umask Value	Event Mask Mnemonic	Description	Comment
0FH	10H	MEM_UNCORE_RETIRED.REMOTE_DRAM	Load instructions retired remote DRAM and remote home-remote cache HITM (Precise Event).	Applicable to two sockets only
0FH	20H	MEM_UNCORE_RETIRED.OTHER_LLC_MISSES	Load instructions retired other LLC miss (Precise Event).	Applicable to two sockets only
0FH	80H	MEM_UNCORE_RETIRED.UNCACHEABLE	Load instructions retired I/O (Precise Event).	Applicable to one and two sockets
10H	01H	FP_COMP_OPS_EXE.X87	Counts the number of FP Computational Uops Executed. The number of FADD, FSUB, FCOM, FMULs, integer MULs and IMULs, FDIVs, FPREMs, FSQRTS, integer DIVs, and IDIVs. This event does not distinguish an FADD used in the middle of a transcendental flow from a separate FADD instruction.	
10H	02H	FP_COMP_OPS_EXE.MMX	Counts number of MMX Uops executed.	
10H	04H	FP_COMP_OPS_EXE.SSE_FP	Counts number of SSE and SSE2 FP uops executed.	
10H	08H	FP_COMP_OPS_EXE.SSE2_INTEGER	Counts number of SSE2 integer uops executed.	
10H	10H	FP_COMP_OPS_EXE.SSE_FP_PACKED	Counts number of SSE FP packed uops executed.	
10H	20H	FP_COMP_OPS_EXE.SSE_FP_SCALAR	Counts number of SSE FP scalar uops executed.	
10H	40H	FP_COMP_OPS_EXE.SSE_SINGLE_PRECISION	Counts number of SSE* FP single precision uops executed.	
10H	80H	FP_COMP_OPS_EXE.SSE_DOUBLE_PRECISION	Counts number of SSE* FP double precision uops executed.	
12H	01H	SIMD_INT_128.PACKED_MPY	Counts number of 128 bit SIMD integer multiply operations.	
12H	02H	SIMD_INT_128.PACKED_SHIFT	Counts number of 128 bit SIMD integer shift operations.	

**Table 19-9. Non-Architectural Performance Events In the Processor Core for Processors Based on Intel® Microarchitecture Code Name Westmere**

Event Num.	Umask Value	Event Mask Mnemonic	Description	Comment
12H	04H	SIMD_INT_128.PACK	Counts number of 128 bit SIMD integer pack operations.	
12H	08H	SIMD_INT_128.UNPACK	Counts number of 128 bit SIMD integer unpack operations.	
12H	10H	SIMD_INT_128.PACKED_LOGICAL	Counts number of 128 bit SIMD integer logical operations.	
12H	20H	SIMD_INT_128.PACKED_ARITH	Counts number of 128 bit SIMD integer arithmetic operations.	
12H	40H	SIMD_INT_128.SHUFFLE_MOVE	Counts number of 128 bit SIMD integer shuffle and move operations.	
13H	01H	LOAD_DISPATCH.RS	Counts number of loads dispatched from the Reservation Station that bypass the Memory Order Buffer.	
13H	02H	LOAD_DISPATCH.RS_DELAYED	Counts the number of delayed RS dispatches at the stage latch. If an RS dispatch can not bypass to LB, it has another chance to dispatch from the one-cycle delayed staging latch before it is written into the LB.	
13H	04H	LOAD_DISPATCH.MOB	Counts the number of loads dispatched from the Reservation Station to the Memory Order Buffer.	
13H	07H	LOAD_DISPATCH.ANY	Counts all loads dispatched from the Reservation Station.	
14H	01H	ARITH.CYCLES_DIV_BUSY	Counts the number of cycles the divider is busy executing divide or square root operations. The divide can be integer, X87 or Streaming SIMD Extensions (SSE). The square root operation can be either X87 or SSE.  Set 'edge =1, invert=1, cmask=1' to count the number of divides.	Count may be incorrect When SMT is on

**Table 19-9. Non-Architectural Performance Events In the Processor Core for Processors Based on Intel® Microarchitecture Code Name Westmere**

Event Num.	Umask Value	Event Mask Mnemonic	Description	Comment
14H	02H	ARITH.MUL	Counts the number of multiply operations executed. This includes integer as well as floating point multiply operations but excludes DPPS mul and MPSAD.	Count may be incorrect When SMT is on
17H	01H	INST_QUEUE_WRITE S	Counts the number of instructions written into the instruction queue every cycle.	
18H	01H	INST_DECODED.DECO	Counts number of instructions that require decoder 0 to be decoded. Usually, this means that the instruction maps to more than 1 uop.	
19H	01H	TWO_UOP_INSTS_D ECODED	An instruction that generates two uops was decoded.	
1EH	01H	INST_QUEUE_WRITE _CYCLES	This event counts the number of cycles during which instructions are written to the instruction queue. Dividing this counter by the number of instructions written to the instruction queue (INST_QUEUE_WRITES) yields the average number of instructions decoded each cycle. If this number is less than four and the pipe stalls, this indicates that the decoder is failing to decode enough instructions per cycle to sustain the 4-wide pipeline.	If SSE* instructions that are 6 bytes or longer arrive one after another, then front end throughput may limit execution speed.
20H	01H	LSD_OVERFLOW	Number of loops that can not stream from the instruction queue.	
24H	01H	L2_RQSTS.LD_HIT	Counts number of loads that hit the L2 cache. L2 loads include both L1D demand misses as well as L1D prefetches. L2 loads can be rejected for various reasons. Only non rejected loads are counted.	

**Table 19-9. Non-Architectural Performance Events In the Processor Core for Processors Based on Intel® Microarchitecture Code Name Westmere**

Event Num.	Umask Value	Event Mask Mnemonic	Description	Comment
24H	02H	L2_RQSTS.LD_MISS	Counts the number of loads that miss the L2 cache. L2 loads include both L1D demand misses as well as L1D prefetches.	
24H	03H	L2_RQSTS.LOADS	Counts all L2 load requests. L2 loads include both L1D demand misses as well as L1D prefetches.	
24H	04H	L2_RQSTS.RFO_HIT	Counts the number of store RFO requests that hit the L2 cache. L2 RFO requests include both L1D demand RFO misses as well as L1D RFO prefetches. Count includes WC memory requests, where the data is not fetched but the permission to write the line is required.	
24H	08H	L2_RQSTS.RFO_MISS	Counts the number of store RFO requests that miss the L2 cache. L2 RFO requests include both L1D demand RFO misses as well as L1D RFO prefetches.	
24H	0CH	L2_RQSTS.RFOS	Counts all L2 store RFO requests. L2 RFO requests include both L1D demand RFO misses as well as L1D RFO prefetches..	
24H	10H	L2_RQSTS.IFETCH_HIT	Counts number of instruction fetches that hit the L2 cache. L2 instruction fetches include both L1I demand misses as well as L1I instruction prefetches.	
24H	20H	L2_RQSTS.IFETCH_MISS	Counts number of instruction fetches that miss the L2 cache. L2 instruction fetches include both L1I demand misses as well as L1I instruction prefetches.	
24H	30H	L2_RQSTS.IFETCHES	Counts all instruction fetches. L2 instruction fetches include both L1I demand misses as well as L1I instruction prefetches.	

**Table 19-9. Non-Architectural Performance Events In the Processor Core for Processors Based on Intel® Microarchitecture Code Name Westmere**

Event Num.	Umask Value	Event Mask Mnemonic	Description	Comment
24H	40H	L2_RQSTS.PREFETCH_HIT	Counts L2 prefetch hits for both code and data.	
24H	80H	L2_RQSTS.PREFETCH_MISS	Counts L2 prefetch misses for both code and data.	
24H	C0H	L2_RQSTS.PREFETCHES	Counts all L2 prefetches for both code and data.	
24H	AAH	L2_RQSTS.MISS	Counts all L2 misses for both code and data.	
24H	FFH	L2_RQSTS.REFERENCES	Counts all L2 requests for both code and data.	
26H	01H	L2_DATA_RQSTS.DEMAND.I_STATE	Counts number of L2 data demand loads where the cache line to be loaded is in the I (invalid) state, i.e. a cache miss. L2 demand loads are both L1D demand misses and L1D prefetches.	
26H	02H	L2_DATA_RQSTS.DEMAND.S_STATE	Counts number of L2 data demand loads where the cache line to be loaded is in the S (shared) state. L2 demand loads are both L1D demand misses and L1D prefetches.	
26H	04H	L2_DATA_RQSTS.DEMAND.E_STATE	Counts number of L2 data demand loads where the cache line to be loaded is in the E (exclusive) state. L2 demand loads are both L1D demand misses and L1D prefetches.	
26H	08H	L2_DATA_RQSTS.DEMAND.M_STATE	Counts number of L2 data demand loads where the cache line to be loaded is in the M (modified) state. L2 demand loads are both L1D demand misses and L1D prefetches.	
26H	0FH	L2_DATA_RQSTS.DEMAND.MESI	Counts all L2 data demand requests. L2 demand loads are both L1D demand misses and L1D prefetches.	
26H	10H	L2_DATA_RQSTS.PREFETCH.I_STATE	Counts number of L2 prefetch data loads where the cache line to be loaded is in the I (invalid) state, i.e. a cache miss.	

**Table 19-9. Non-Architectural Performance Events In the Processor Core for Processors Based on Intel® Microarchitecture Code Name Westmere**

Event Num.	Umask Value	Event Mask Mnemonic	Description	Comment
26H	20H	L2_DATA_RQSTS.PREFETCH.S_STATE	Counts number of L2 prefetch data loads where the cache line to be loaded is in the S (shared) state. A prefetch RFO will miss on an S state line, while a prefetch read will hit on an S state line.	
26H	40H	L2_DATA_RQSTS.PREFETCH.E_STATE	Counts number of L2 prefetch data loads where the cache line to be loaded is in the E (exclusive) state.	
26H	80H	L2_DATA_RQSTS.PREFETCH.M_STATE	Counts number of L2 prefetch data loads where the cache line to be loaded is in the M (modified) state.	
26H	FOH	L2_DATA_RQSTS.PREFETCH.MESI	Counts all L2 prefetch requests.	
26H	FFH	L2_DATA_RQSTS.ANY	Counts all L2 data requests.	
27H	01H	L2_WRITE.RFO.I_STATE	Counts number of L2 demand store RFO requests where the cache line to be loaded is in the I (invalid) state, i.e, a cache miss. The L1D prefetcher does not issue a RFO prefetch.	This is a demand RFO request
27H	02H	L2_WRITE.RFO.S_STATE	Counts number of L2 store RFO requests where the cache line to be loaded is in the S (shared) state. The L1D prefetcher does not issue a RFO prefetch.	This is a demand RFO request
27H	08H	L2_WRITE.RFO.M_STATE	Counts number of L2 store RFO requests where the cache line to be loaded is in the M (modified) state. The L1D prefetcher does not issue a RFO prefetch.	This is a demand RFO request
27H	0EH	L2_WRITE.RFO.HIT	Counts number of L2 store RFO requests where the cache line to be loaded is in either the S, E or M states. The L1D prefetcher does not issue a RFO prefetch.	This is a demand RFO request
27H	0FH	L2_WRITE.RFO.MESI	Counts all L2 store RFO requests. The L1D prefetcher does not issue a RFO prefetch.	This is a demand RFO request



**Table 19-9. Non-Architectural Performance Events In the Processor Core for Processors Based on Intel® Microarchitecture Code Name Westmere**

Event Num.	Umask Value	Event Mask Mnemonic	Description	Comment
27H	10H	L2_WRITE.LOCK.I_STATE	Counts number of L2 demand lock RFO requests where the cache line to be loaded is in the I (invalid) state, i.e. a cache miss.	
27H	20H	L2_WRITE.LOCK.S_STATE	Counts number of L2 lock RFO requests where the cache line to be loaded is in the S (shared) state.	
27H	40H	L2_WRITE.LOCK.E_STATE	Counts number of L2 demand lock RFO requests where the cache line to be loaded is in the E (exclusive) state.	
27H	80H	L2_WRITE.LOCK.M_STATE	Counts number of L2 demand lock RFO requests where the cache line to be loaded is in the M (modified) state.	
27H	E0H	L2_WRITE.LOCK.HIT	Counts number of L2 demand lock RFO requests where the cache line to be loaded is in either the S, E, or M state.	
27H	F0H	L2_WRITE.LOCK.MESI	Counts all L2 demand lock RFO requests.	
28H	01H	L1D_WB_L2.I_STATE	Counts number of L1 writebacks to the L2 where the cache line to be written is in the I (invalid) state, i.e. a cache miss.	
28H	02H	L1D_WB_L2.S_STATE	Counts number of L1 writebacks to the L2 where the cache line to be written is in the S state.	
28H	04H	L1D_WB_L2.E_STATE	Counts number of L1 writebacks to the L2 where the cache line to be written is in the E (exclusive) state.	
28H	08H	L1D_WB_L2.M_STATE	Counts number of L1 writebacks to the L2 where the cache line to be written is in the M (modified) state.	
28H	0FH	L1D_WB_L2.MESI	Counts all L1 writebacks to the L2 .	

**Table 19-9. Non-Architectural Performance Events In the Processor Core for Processors Based on Intel® Microarchitecture Code Name Westmere**

Event Num.	Umask Value	Event Mask Mnemonic	Description	Comment
2EH	41H	L3_LAT_CACHE.MISS	Counts uncore Last Level Cache misses. Because cache hierarchy, cache sizes and other implementation-specific characteristics; value comparison to estimate performance differences is not recommended.	see Table 19-1
2EH	4FH	L3_LAT_CACHE.REFERENCE	Counts uncore Last Level Cache references. Because cache hierarchy, cache sizes and other implementation-specific characteristics; value comparison to estimate performance differences is not recommended.	see Table 19-1
3CH	00H	CPU_CLK_UNHALTED.THREAD_P	Counts the number of thread cycles while the thread is not in a halt state. The thread enters the halt state when it is running the HLT instruction. The core frequency may change from time to time due to power or thermal throttling.	see Table 19-1
3CH	01H	CPU_CLK_UNHALTED.REF_P	Increments at the frequency of TSC when not halted.	see Table 19-1
49H	01H	DTLB_MISSES.ANY	Counts the number of misses in the STLB which causes a page walk.	
49H	02H	DTLB_MISSES.WALK_COMPLETED	Counts number of misses in the STLB which resulted in a completed page walk.	
49H	04H	DTLB_MISSES.WALK_CYCLES	Counts cycles of page walk due to misses in the STLB.	
49H	10H	DTLB_MISSES.STLB_HIT	Counts the number of DTLB first level misses that hit in the second level TLB. This event is only relevant if the core contains multiple DTLB levels.	
49H	20H	DTLB_MISSES.PDE_MISS	Number of DTLB misses caused by low part of address, includes references to 2M pages because 2M pages do not use the PDE.	

**Table 19-9. Non-Architectural Performance Events In the Processor Core for Processors Based on Intel® Microarchitecture Code Name Westmere**

Event Num.	Umask Value	Event Mask Mnemonic	Description	Comment
49H	80H	DTLB_MISSES.LARGE_WALK_COMPLETED	Counts number of completed large page walks due to misses in the STLB.	
4CH	01H	LOAD_HIT_PRE	Counts load operations sent to the L1 data cache while a previous SSE prefetch instruction to the same cache line has started prefetching but has not yet finished.	Counter 0, 1 only
4EH	01H	L1D_PREFETCH.REQUESTS	Counts number of hardware prefetch requests dispatched out of the prefetch FIFO.	Counter 0, 1 only
4EH	02H	L1D_PREFETCH.MISS	Counts number of hardware prefetch requests that miss the L1D. There are two prefetchers in the L1D. A streamer, which predicts lines sequentially after this one should be fetched, and the IP prefetcher that remembers access patterns for the current instruction. The streamer prefetcher stops on an L1D hit, while the IP prefetcher does not.	Counter 0, 1 only
4EH	04H	L1D_PREFETCH.TRIGGERS	Counts number of prefetch requests triggered by the Finite State Machine and pushed into the prefetch FIFO. Some of the prefetch requests are dropped due to overwrites or competition between the IP index prefetcher and streamer prefetcher. The prefetch FIFO contains 4 entries.	Counter 0, 1 only
4FH	10H	EPT.WALK_CYCLES	Counts Extended Page walk cycles.	
51H	01H	L1D.REPL	Counts the number of lines brought into the L1 data cache.	Counter 0, 1 only
51H	02H	L1D.M_REPL	Counts the number of modified lines brought into the L1 data cache.	Counter 0, 1 only
51H	04H	L1D.M_EVICT	Counts the number of modified lines evicted from the L1 data cache due to replacement.	Counter 0, 1 only

**Table 19-9. Non-Architectural Performance Events In the Processor Core for Processors Based on Intel® Microarchitecture Code Name Westmere**

Event Num.	Umask Value	Event Mask Mnemonic	Description	Comment
51H	08H	L1D.M_SNOOP_EVICT	Counts the number of modified lines evicted from the L1 data cache due to snoop HITM intervention.	Counter 0, 1 only
52H	01H	L1D_CACHE_PREFETCH_LOCK_FB_HIT	Counts the number of cacheable load lock speculated instructions accepted into the fill buffer.	
60H	01H	OFFCORE_REQUESTS_OUTSTANDING.DEMAND.READ_DATA	Counts weighted cycles of offcore demand data read requests. Does not include L2 prefetch requests.	counter 0
60H	02H	OFFCORE_REQUESTS_OUTSTANDING.DEMAND.READ_CODE	Counts weighted cycles of offcore demand code read requests. Does not include L2 prefetch requests.	counter 0
60H	04H	OFFCORE_REQUESTS_OUTSTANDING.DEMAND.RFO	Counts weighted cycles of offcore demand RFO requests. Does not include L2 prefetch requests.	counter 0
60H	08H	OFFCORE_REQUESTS_OUTSTANDING.ANY.READ	Counts weighted cycles of offcore read requests of any kind. Include L2 prefetch requests.	counter 0
63H	01H	CACHE_LOCK_CYCLE.S.L1D_L2	Cycle count during which the L1D and L2 are locked. A lock is asserted when there is a locked memory access, due to uncacheable memory, a locked operation that spans two cache lines, or a page walk from an uncacheable page table. This event does not cause locks, it merely detects them.	Counter 0, 1 only. L1D and L2 locks have a very high performance penalty and it is highly recommended to avoid such accesses.
63H	02H	CACHE_LOCK_CYCLE.S.L1D	Counts the number of cycles that cacheline in the L1 data cache unit is locked.	Counter 0, 1 only.
6CH	01H	IO_TRANSACTIONS	Counts the number of completed I/O transactions.	
80H	01H	L1I.HITS	Counts all instruction fetches that hit the L1 instruction cache.	

**Table 19-9. Non-Architectural Performance Events In the Processor Core for Processors Based on Intel® Microarchitecture Code Name Westmere**

Event Num.	Umask Value	Event Mask Mnemonic	Description	Comment
80H	02H	L1I.MISSES	Counts all instruction fetches that miss the L1I cache. This includes instruction cache misses, streaming buffer misses, victim cache misses and uncacheable fetches. An instruction fetch miss is counted only once and not once for every cycle it is outstanding.	
80H	03H	L1I.READS	Counts all instruction fetches, including uncacheable fetches that bypass the L1I.	
80H	04H	L1I.CYCLES_STALLED	Cycle counts for which an instruction fetch stalls due to a L1I cache miss, ITLB miss or ITLB fault.	
82H	01H	LARGE_ITLB.HIT	Counts number of large ITLB hits.	
85H	01H	ITLB_MISSES.ANY	Counts the number of misses in all levels of the ITLB which causes a page walk.	
85H	02H	ITLB_MISSES.WALK_COMPLETED	Counts number of misses in all levels of the ITLB which resulted in a completed page walk.	
85H	04H	ITLB_MISSES.WALK_CYCLES	Counts ITLB miss page walk cycles.	
85H	80H	ITLB_MISSES.LARGE_WALK_COMPLETED	Counts number of completed large page walks due to misses in the STLB.	
87H	01H	ILD_STALL.LCP	Cycles Instruction Length Decoder stalls due to length changing prefixes: 66, 67 or REX.W (for EM64T) instructions which change the length of the decoded instruction.	
87H	02H	ILD_STALL.MRU	Instruction Length Decoder stall cycles due to Branch Prediction Unit (PBU) Most Recently Used (MRU) bypass.	
87H	04H	ILD_STALL.IQ_FULL	Stall cycles due to a full instruction queue.	

**Table 19-9. Non-Architectural Performance Events In the Processor Core for Processors Based on Intel® Microarchitecture Code Name Westmere**

Event Num.	Umask Value	Event Mask Mnemonic	Description	Comment
87H	08H	ILD_STALL.REGEN	Counts the number of regen stalls.	
87H	0FH	ILD_STALL.ANY	Counts any cycles the Instruction Length Decoder is stalled.	
88H	01H	BR_INST_EXEC.COND	Counts the number of conditional near branch instructions executed, but not necessarily retired.	
88H	02H	BR_INST_EXEC.DIRECT	Counts all unconditional near branch instructions excluding calls and indirect branches.	
88H	04H	BR_INST_EXEC.INDIRECT_NON_CALL	Counts the number of executed indirect near branch instructions that are not calls.	
88H	07H	BR_INST_EXEC.NON_CALLS	Counts all non call near branch instructions executed, but not necessarily retired.	
88H	08H	BR_INST_EXEC.RETURN_NEAR	Counts indirect near branches that have a return mnemonic.	
88H	10H	BR_INST_EXEC.DIRECT_NEAR_CALL	Counts unconditional near call branch instructions, excluding non call branch, executed.	
88H	20H	BR_INST_EXEC.INDIRECT_NEAR_CALL	Counts indirect near calls, including both register and memory indirect, executed.	
88H	30H	BR_INST_EXEC.NEAR_CALLS	Counts all near call branches executed, but not necessarily retired.	
88H	40H	BR_INST_EXEC.TAKEN	Counts taken near branches executed, but not necessarily retired.	
88H	7FH	BR_INST_EXEC.ANY	Counts all near executed branches (not necessarily retired). This includes only instructions and not micro-op branches. Frequent branching is not necessarily a major performance issue. However frequent branch mispredictions may be a problem.	

**Table 19-9. Non-Architectural Performance Events In the Processor Core for Processors Based on Intel® Microarchitecture Code Name Westmere**

Event Num.	Umask Value	Event Mask Mnemonic	Description	Comment
89H	01H	BR_MISP_EXEC.COND	Counts the number of mispredicted conditional near branch instructions executed, but not necessarily retired.	
89H	02H	BR_MISP_EXEC.DIRECT	Counts mispredicted macro unconditional near branch instructions, excluding calls and indirect branches (should always be 0).	
89H	04H	BR_MISP_EXEC.INDIRECT_NON_CALL	Counts the number of executed mispredicted indirect near branch instructions that are not calls.	
89H	07H	BR_MISP_EXEC.NON_CALLS	Counts mispredicted non call near branches executed, but not necessarily retired.	
89H	08H	BR_MISP_EXEC.RETURN_NEAR	Counts mispredicted indirect branches that have a rear return mnemonic.	
89H	10H	BR_MISP_EXEC.DIRECT_NEAR_CALL	Counts mispredicted non-indirect near calls executed, (should always be 0).	
89H	20H	BR_MISP_EXEC.INDIRECT_NEAR_CALL	Counts mispredicted indirect near calls executed, including both register and memory indirect.	
89H	30H	BR_MISP_EXEC.NEAR_CALLS	Counts all mispredicted near call branches executed, but not necessarily retired.	
89H	40H	BR_MISP_EXEC.TAKEN	Counts executed mispredicted near branches that are taken, but not necessarily retired.	
89H	7FH	BR_MISP_EXEC.ANY	Counts the number of mispredicted near branch instructions that were executed, but not necessarily retired.	

**Table 19-9. Non-Architectural Performance Events In the Processor Core for Processors Based on Intel® Microarchitecture Code Name Westmere**

Event Num.	Umask Value	Event Mask Mnemonic	Description	Comment
A2H	01H	RESOURCE_STALLS.ANY	Counts the number of Allocator resource related stalls. Includes register renaming buffer entries, memory buffer entries. In addition to resource related stalls, this event counts some other events. Includes stalls arising during branch misprediction recovery, such as if retirement of the mispredicted branch is delayed and stalls arising while store buffer is draining from synchronizing operations.	Does not include stalls due to SuperQ (off core) queue full, too many cache misses, etc.
A2H	02H	RESOURCE_STALLS.LOAD	Counts the cycles of stall due to lack of load buffer for load operation.	
A2H	04H	RESOURCE_STALLS.RS_FULL	This event counts the number of cycles when the number of instructions in the pipeline waiting for execution reaches the limit the processor can handle. A high count of this event indicates that there are long latency operations in the pipe (possibly load and store operations that miss the L2 cache, or instructions dependent upon instructions further down the pipeline that have yet to retire.	When RS is full, new instructions can not enter the reservation station and start execution.
A2H	08H	RESOURCE_STALLS.STORE	This event counts the number of cycles that a resource related stall will occur due to the number of store instructions reaching the limit of the pipeline, (i.e. all store buffers are used). The stall ends when a store instruction commits its data to the cache or memory.	
A2H	10H	RESOURCE_STALLS.REORDER_BUFFER_FULL	Counts the cycles of stall due to re-order buffer full.	
A2H	20H	RESOURCE_STALLS.FPU_PCW	Counts the number of cycles while execution was stalled due to writing the floating-point unit (FPU) control word.	



**Table 19-9. Non-Architectural Performance Events In the Processor Core for Processors Based on Intel® Microarchitecture Code Name Westmere**

Event Num.	Umask Value	Event Mask Mnemonic	Description	Comment
A2H	40H	RESOURCE_STALLS.MXCSR	Stalls due to the MXCSR register rename occurring to close to a previous MXCSR rename. The MXCSR provides control and status for the MMX registers.	
A2H	80H	RESOURCE_STALLS.OTHER	Counts the number of cycles while execution was stalled due to other resource issues.	
A6H	01H	MACRO_INSTS.FUSIONS_DECODED	Counts the number of instructions decoded that are macro-fused but not necessarily executed or retired.	
A7H	01H	BACLEAR_FORCE_IQ	Counts number of times a BACLEAR was forced by the Instruction Queue. The IQ is also responsible for providing conditional branch prediction direction based on a static scheme and dynamic data provided by the L2 Branch Prediction Unit. If the conditional branch target is not found in the Target Array and the IQ predicts that the branch is taken, then the IQ will force the Branch Address Calculator to issue a BACLEAR. Each BACLEAR asserted by the BAC generates approximately an 8 cycle bubble in the instruction fetch pipeline.	
A8H	01H	LSD.UOPS	Counts the number of micro-ops delivered by loop stream detector.	Use cmask=1 and invert to count cycles
AEH	01H	ITLB_FLUSH	Counts the number of ITLB flushes.	
BOH	01H	OFFCORE_REQUESTS.DEMAND.READ_DATA	Counts number of offcore demand data read requests. Does not count L2 prefetch requests.	
BOH	02H	OFFCORE_REQUESTS.DEMAND.READ_CODE	Counts number of offcore demand code read requests. Does not count L2 prefetch requests.	

**Table 19-9. Non-Architectural Performance Events In the Processor Core for Processors Based on Intel® Microarchitecture Code Name Westmere**

Event Num.	Umask Value	Event Mask Mnemonic	Description	Comment
BOH	04H	OFFCORE_REQUEST S.DEMAND.RFO	Counts number of offcore demand RFO requests. Does not count L2 prefetch requests.	
BOH	08H	OFFCORE_REQUEST S.ANY.READ	Counts number of offcore read requests. Includes L2 prefetch requests.	
BOH	10H	OFFCORE_REQUEST S.ANY.RFO	Counts number of offcore RFO requests. Includes L2 prefetch requests.	
BOH	40H	OFFCORE_REQUEST S.L1D_WRITEBACK	Counts number of L1D writebacks to the uncore.	
BOH	80H	OFFCORE_REQUEST S.ANY	Counts all offcore requests.	
B1H	01H	UOPS_EXECUTED.PO RT0	Counts number of Uops executed that were issued on port 0. Port 0 handles integer arithmetic, SIMD and FP add Uops.	
B1H	02H	UOPS_EXECUTED.PO RT1	Counts number of Uops executed that were issued on port 1. Port 1 handles integer arithmetic, SIMD, integer shift, FP multiply and FP divide Uops.	
B1H	04H	UOPS_EXECUTED.PO RT2_CORE	Counts number of Uops executed that were issued on port 2. Port 2 handles the load Uops. This is a core count only and can not be collected per thread.	
B1H	08H	UOPS_EXECUTED.PO RT3_CORE	Counts number of Uops executed that were issued on port 3. Port 3 handles store Uops. This is a core count only and can not be collected per thread.	
B1H	10H	UOPS_EXECUTED.PO RT4_CORE	Counts number of Uops executed that where issued on port 4. Port 4 handles the value to be stored for the store Uops issued on port 3. This is a core count only and can not be collected per thread.	

**Table 19-9. Non-Architectural Performance Events In the Processor Core for Processors Based on Intel® Microarchitecture Code Name Westmere**

Event Num.	Umask Value	Event Mask Mnemonic	Description	Comment
B1H	1FH	UOPS_EXECUTED.CORE_ACTIVE_CYCLES_NO_PORTS	Counts number of cycles there are one or more uops being executed and were issued on ports 0-4. This is a core count only and can not be collected per thread.	
B1H	20H	UOPS_EXECUTED.PORT5	Counts number of Uops executed that where issued on port 5.	
B1H	3FH	UOPS_EXECUTED.CORE_ACTIVE_CYCLES	Counts number of cycles there are one or more uops being executed on any ports. This is a core count only and can not be collected per thread.	
B1H	40H	UOPS_EXECUTED.PORT015	Counts number of Uops executed that where issued on port 0, 1, or 5.	use cmask=1, invert=1 to count stall cycles
B1H	80H	UOPS_EXECUTED.PORT234	Counts number of Uops executed that where issued on port 2, 3, or 4.	
B2H	01H	OFFCORE_REQUESTS_SQ_FULL	Counts number of cycles the SQ is full to handle off-core requests.	
B3H	01H	SNOOPQ_REQUESTS_OUTSTANDING.DATA	Counts weighted cycles of snoopq requests for data. Counter 0 only.	Use cmask=1 to count cycles not empty.
B3H	02H	SNOOPQ_REQUESTS_OUTSTANDING.INVALIDATE	Counts weighted cycles of snoopq invalidate requests. Counter 0 only.	Use cmask=1 to count cycles not empty.
B3H	04H	SNOOPQ_REQUESTS_OUTSTANDING.CODE	Counts weighted cycles of snoopq requests for code. Counter 0 only.	Use cmask=1 to count cycles not empty.
B4H	01H	SNOOPQ_REQUESTS.CODE	Counts the number of snoop code requests.	
B4H	02H	SNOOPQ_REQUESTS.DATA	Counts the number of snoop data requests.	
B4H	04H	SNOOPQ_REQUESTS.INVALIDATE	Counts the number of snoop invalidate requests.	
B7H	01H	OFF_CORE_RESPONSE_0	see Section 18.6.1.3, "Off-core Response Performance Monitoring in the Processor Core"	Requires programming MSR 01A6H

**Table 19-9. Non-Architectural Performance Events In the Processor Core for Processors Based on Intel® Microarchitecture Code Name Westmere**

Event Num.	Umask Value	Event Mask Mnemonic	Description	Comment
B8H	01H	SNOOP_RESPONSE.HIT	Counts HIT snoop response sent by this thread in response to a snoop request.	
B8H	02H	SNOOP_RESPONSE.HITE	Counts HIT E snoop response sent by this thread in response to a snoop request.	
B8H	04H	SNOOP_RESPONSE.HITM	Counts HIT M snoop response sent by this thread in response to a snoop request.	
BBH	01H	OFF_CORE_RESPONSE.E_1	see Section 18.6.1.3, "Off-core Response Performance Monitoring in the Processor Core"	Use MSR 01A7H
COH	00H	INST_RETIRED.ANY_P	See Table 19-1 Notes: INST_RETIRED.ANY is counted by a designated fixed counter. INST_RETIRED.ANY_P is counted by a programmable counter and is an architectural performance event. Event is supported if CPUID.A.EBX[1] = 0.	Counting: Faulting executions of GETSEC/VM entry/VM Exit/MWait will not count as retired instructions.
COH	02H	INST_RETIRED.X87	Counts the number of floating point computational operations retired: floating point computational operations executed by the assist handler and sub-operations of complex floating point instructions like transcendental instructions.	
COH	04H	INST_RETIRED.MMX	Counts the number of retired: MMX instructions.	
C2H	01H	UOPS_RETIRED.ANY	Counts the number of micro-ops retired, (macro-fused=1, micro-fused=2, others=1; maximum count of 8 per cycle). Most instructions are composed of one or two micro-ops. Some instructions are decoded into longer sequences such as repeat instructions, floating point transcendental instructions, and assists.	Use cmask=1 and invert to count active cycles or stalled cycles

**Table 19-9. Non-Architectural Performance Events In the Processor Core for Processors Based on Intel® Microarchitecture Code Name Westmere**

Event Num.	Umask Value	Event Mask Mnemonic	Description	Comment
C2H	02H	UOPS_RETIRED.RETIRE_SLOTS	Counts the number of retirement slots used each cycle	
C2H	04H	UOPS_RETIRED.MACRO_FUSED	Counts number of macro-fused uops retired.	
C3H	01H	MACHINE_CLEAR.CYCLES	Counts the cycles machine clear is asserted.	
C3H	02H	MACHINE_CLEAR.MEM_ORDER	Counts the number of machine clears due to memory order conflicts.	
C3H	04H	MACHINE_CLEAR.SMC	Counts the number of times that a program writes to a code section. Self-modifying code causes a severe penalty in all Intel 64 and IA-32 processors. The modified cache line is written back to the L2 and L3 caches.	
C4H	00H	BR_INST_RETIRED.ALL_BRANCHES	Branch instructions at retirement	See Table 19-1
C4H	01H	BR_INST_RETIRED.CONDITIONAL	Counts the number of conditional branch instructions retired.	
C4H	02H	BR_INST_RETIRED.NEAR_CALL	Counts the number of direct & indirect near unconditional calls retired.	
C5H	00H	BR_MISP_RETIRED.ALL_BRANCHES	Mispredicted branch instructions at retirement	See Table 19-1
C5H	01H	BR_MISP_RETIRED.CONDITIONAL	Counts mispredicted conditional retired calls.	
C5H	02H	BR_MISP_RETIRED.NEAR_CALL	Counts mispredicted direct & indirect near unconditional retired calls.	
C5H	04H	BR_MISP_RETIRED.ALL_BRANCHES	Counts all mispredicted retired calls.	
C7H	01H	SSEX_UOPS_RETIRED.PACKED_SINGLE	Counts SIMD packed single-precision floating point Uops retired.	
C7H	02H	SSEX_UOPS_RETIRED.SCALAR_SINGLE	Counts SIMD scalar single-precision floating point Uops retired.	

**Table 19-9. Non-Architectural Performance Events In the Processor Core for Processors Based on Intel® Microarchitecture Code Name Westmere**

Event Num.	Umask Value	Event Mask Mnemonic	Description	Comment
C7H	04H	SSEX_UOPS_RETIRE D.PACKED_DOUBLE	Counts SIMD packed double-precision floating point Uops retired.	
C7H	08H	SSEX_UOPS_RETIRE D.SCALAR_DOUBLE	Counts SIMD scalar double-precision floating point Uops retired.	
C7H	10H	SSEX_UOPS_RETIRE D.VECTOR_INTEGER	Counts 128-bit SIMD vector integer Uops retired.	
C8H	20H	ITLB_MISS_RETIRE	Counts the number of retired instructions that missed the ITLB when the instruction was fetched.	
CBH	01H	MEM_LOAD_RETIRE .L1D_HIT	Counts number of retired loads that hit the L1 data cache.	
CBH	02H	MEM_LOAD_RETIRE .L2_HIT	Counts number of retired loads that hit the L2 data cache.	
CBH	04H	MEM_LOAD_RETIRE .L3_UNSHARED_HIT	Counts number of retired loads that hit their own, unshared lines in the L3 cache.	
CBH	08H	MEM_LOAD_RETIRE .OTHER_CORE_L2_HIT_HITM	Counts number of retired loads that hit in a sibling core's L2 (on die core). Since the L3 is inclusive of all cores on the package, this is an L3 hit. This counts both clean or modified hits.	
CBH	10H	MEM_LOAD_RETIRE .L3_MISS	Counts number of retired loads that miss the L3 cache. The load was satisfied by a remote socket, local memory or an IOH.	
CBH	40H	MEM_LOAD_RETIRE .HIT_LFB	Counts number of retired loads that miss the L1D and the address is located in an allocated line fill buffer and will soon be committed to cache. This is counting secondary L1D misses.	

**Table 19-9. Non-Architectural Performance Events In the Processor Core for Processors Based on Intel® Microarchitecture Code Name Westmere**

Event Num.	Umask Value	Event Mask Mnemonic	Description	Comment
CBH	80H	MEM_LOAD_RETIRED.DTLB_MISS	Counts the number of retired loads that missed the DTLB. The DTLB miss is not counted if the load operation causes a fault. This event counts loads from cacheable memory only. The event does not count loads by software prefetches. Counts both primary and secondary misses to the TLB.	
CCH	01H	FP_MMX_TRANS.TO_FP	Counts the first floating-point instruction following any MMX instruction. You can use this event to estimate the penalties for the transitions between floating-point and MMX technology states.	
CCH	02H	FP_MMX_TRANS.TO_MMX	Counts the first MMX instruction following a floating-point instruction. You can use this event to estimate the penalties for the transitions between floating-point and MMX technology states.	
CCH	03H	FP_MMX_TRANS.ANY	Counts all transitions from floating point to MMX instructions and from MMX instructions to floating point instructions. You can use this event to estimate the penalties for the transitions between floating-point and MMX technology states.	
DOH	01H	MACRO_INSTS.DECODED	Counts the number of instructions decoded, (but not necessarily executed or retired).	
D1H	01H	UOPS_DECODED.STALL_CYCLES	Counts the cycles of decoder stalls. INV=1, Cmask= 1	
D1H	02H	UOPS_DECODED.MS	Counts the number of Uops decoded by the Microcode Sequencer, MS. The MS delivers uops when the instruction is more than 4 uops long or a microcode assist is occurring.	

**Table 19-9. Non-Architectural Performance Events In the Processor Core for Processors Based on Intel® Microarchitecture Code Name Westmere**

Event Num.	Umask Value	Event Mask Mnemonic	Description	Comment
D1H	04H	UOPS_DECODED.ESP_FOLDING	Counts number of stack pointer (ESP) instructions decoded: push , pop , call , ret, etc. ESP instructions do not generate a Uop to increment or decrement ESP. Instead, they update an ESP_Offset register that keeps track of the delta to the current value of the ESP register.	
D1H	08H	UOPS_DECODED.ESP_SYNC	Counts number of stack pointer (ESP) sync operations where an ESP instruction is corrected by adding the ESP offset register to the current value of the ESP register.	
D2H	01H	RAT_STALLS.FLAGS	Counts the number of cycles during which execution stalled due to several reasons, one of which is a partial flag register stall. A partial register stall may occur when two conditions are met: 1) an instruction modifies some, but not all, of the flags in the flag register and 2) the next instruction, which depends on flags, depends on flags that were not modified by this instruction.	
D2H	02H	RAT_STALLS.REGISTERS	This event counts the number of cycles instruction execution latency became longer than the defined latency because the instruction used a register that was partially written by previous instruction.	



**Table 19-9. Non-Architectural Performance Events In the Processor Core for Processors Based on Intel® Microarchitecture Code Name Westmere**

Event Num.	Umask Value	Event Mask Mnemonic	Description	Comment
D2H	04H	RAT_STALLS.ROB_READ_PORT	Counts the number of cycles when ROB read port stalls occurred, which did not allow new micro-ops to enter the out-of-order pipeline. Note that, at this stage in the pipeline, additional stalls may occur at the same cycle and prevent the stalled micro-ops from entering the pipe. In such a case, micro-ops retry entering the execution pipe in the next cycle and the ROB-read port stall is counted again.	
D2H	08H	RAT_STALLS.SCOREBOARD	Counts the cycles where we stall due to microarchitecturally required serialization. Microcode scoreboarding stalls.	
D2H	0FH	RAT_STALLS.ANY	Counts all Register Allocation Table stall cycles due to: Cycles when ROB read port stalls occurred, which did not allow new micro-ops to enter the execution pipe. Cycles when partial register stalls occurred Cycles when flag stalls occurred Cycles floating-point unit (FPU) status word stalls occurred. To count each of these conditions separately use the events: RAT_STALLS.ROB_READ_PORT, RAT_STALLS.PARTIAL, RAT_STALLS.FLAGS, and RAT_STALLS.FPSW.	
D4H	01H	SEG_RENAME_STALLS	Counts the number of stall cycles due to the lack of renaming resources for the ES, DS, FS, and GS segment registers. If a segment is renamed but not retired and a second update to the same segment occurs, a stall occurs in the front-end of the pipeline until the renamed segment retires.	

**Table 19-9. Non-Architectural Performance Events In the Processor Core for Processors Based on Intel® Microarchitecture Code Name Westmere**

Event Num.	Umask Value	Event Mask Mnemonic	Description	Comment
D5H	01H	ES_REG_RENAMES	Counts the number of times the ES segment register is renamed.	
DBH	01H	UOP_UNFUSION	Counts unfusion events due to floating point exception to a fused uop.	
E0H	01H	BR_INST_DECODED	Counts the number of branch instructions decoded.	
E5H	01H	BPU_MISSED_CALL_RET	Counts number of times the Branch Prediction Unit missed predicting a call or return branch.	
E6H	01H	BACLEAR.CLEAR	Counts the number of times the front end is resteeered, mainly when the Branch Prediction Unit cannot provide a correct prediction and this is corrected by the Branch Address Calculator at the front end. This can occur if the code has many branches such that they cannot be consumed by the BPU. Each BACLEAR asserted by the BAC generates approximately an 8 cycle bubble in the instruction fetch pipeline. The effect on total execution time depends on the surrounding code.	
E6H	02H	BACLEAR.BAD_TARGET	Counts number of Branch Address Calculator clears (BACLEAR) asserted due to conditional branch instructions in which there was a target hit but the direction was wrong. Each BACLEAR asserted by the BAC generates approximately an 8 cycle bubble in the instruction fetch pipeline.	
E8H	01H	BPU_CLEAR.EARLY	Counts early (normal) Branch Prediction Unit clears: BPU predicted a taken branch after incorrectly assuming that it was not taken.	The BPU clear leads to 2 cycle bubble in the Front End.

**Table 19-9. Non-Architectural Performance Events In the Processor Core for Processors Based on Intel® Microarchitecture Code Name Westmere**

Event Num.	Umask Value	Event Mask Mnemonic	Description	Comment
E8H	02H	BPU_CLEAR.S.LATE	Counts late Branch Prediction Unit clears due to Most Recently Used conflicts. The PBU clear leads to a 3 cycle bubble in the Front End.	
ECH	01H	THREAD_ACTIVE	Counts cycles threads are active.	
FOH	01H	L2_TRANSACTIONS.LOAD	Counts L2 load operations due to HW prefetch or demand loads.	
FOH	02H	L2_TRANSACTIONS.RFO	Counts L2 RFO operations due to HW prefetch or demand RFOs.	
FOH	04H	L2_TRANSACTIONS.IFETCH	Counts L2 instruction fetch operations due to HW prefetch or demand ifetch.	
FOH	08H	L2_TRANSACTIONS.PREFETCH	Counts L2 prefetch operations.	
FOH	10H	L2_TRANSACTIONS.L1D_WB	Counts L1D writeback operations to the L2.	
FOH	20H	L2_TRANSACTIONS.FILL	Counts L2 cache line fill operations due to load, RFO, L1D writeback or prefetch.	
FOH	40H	L2_TRANSACTIONS.WB	Counts L2 writeback operations to the L3.	
FOH	80H	L2_TRANSACTIONS.ANY	Counts all L2 cache operations.	
F1H	02H	L2_LINES_IN.S_STATE	Counts the number of cache lines allocated in the L2 cache in the S (shared) state.	
F1H	04H	L2_LINES_IN.E_STATE	Counts the number of cache lines allocated in the L2 cache in the E (exclusive) state.	
F1H	07H	L2_LINES_IN.ANY	Counts the number of cache lines allocated in the L2 cache.	
F2H	01H	L2_LINES_OUT.DEMAND_CLEAN	Counts L2 clean cache lines evicted by a demand request.	
F2H	02H	L2_LINES_OUT.DEMAND_DIRTY	Counts L2 dirty (modified) cache lines evicted by a demand request.	
F2H	04H	L2_LINES_OUT.PREFETCH_CLEAN	Counts L2 clean cache line evicted by a prefetch request.	

**Table 19-9. Non-Architectural Performance Events In the Processor Core for Processors Based on Intel® Microarchitecture Code Name Westmere**

Event Num.	Umask Value	Event Mask Mnemonic	Description	Comment
F2H	08H	L2_LINES_OUT.PREFETCH_DIRTY	Counts L2 modified cache line evicted by a prefetch request.	
F2H	0FH	L2_LINES_OUT.ANY	Counts all L2 cache lines evicted for any reason.	
F4H	04H	SQ_MISC.LRU_HINTS	Counts number of Super Queue LRU hints sent to L3.	
F4H	10H	SQ_MISC.SPLIT_LOCK	Counts the number of SQ lock splits across a cache line.	
F6H	01H	SQ_FULL_STALL_CYCLES	Counts cycles the Super Queue is full. Neither of the threads on this core will be able to access the uncore.	
F7H	01H	FP_ASSIST.ALL	Counts the number of floating point operations executed that required micro-code assist intervention. Assists are required in the following cases: SSE instructions, (Denormal input when the DAZ flag is off or Underflow result when the FTZ flag is off); x87 instructions, (NaN or denormal are loaded to a register or used as input from memory, Division by 0 or Underflow output).	
F7H	02H	FP_ASSIST.OUTPUT	Counts number of floating point micro-code assist when the output value (destination register) is invalid.	
F7H	04H	FP_ASSIST.INPUT	Counts number of floating point micro-code assist when the input value (one of the source operands to an FP instruction) is invalid.	
FDH	01H	SIMD_INT_64.PACKED_MPY	Counts number of SIMD integer 64 bit packed multiply operations.	
FDH	02H	SIMD_INT_64.PACKED_SHIFT	Counts number of SIMD integer 64 bit packed shift operations.	
FDH	04H	SIMD_INT_64.PACK	Counts number of SIMD integer 64 bit pack operations.	
FDH	08H	SIMD_INT_64.UNPACK	Counts number of SIMD integer 64 bit unpack operations.	

**Table 19-9. Non-Architectural Performance Events In the Processor Core for Processors Based on Intel® Microarchitecture Code Name Westmere**

Event Num.	Umask Value	Event Mask Mnemonic	Description	Comment
FDH	10H	SIMD_INT_64.PACKED_LOGICAL	Counts number of SIMD integer 64 bit logical operations.	
FDH	20H	SIMD_INT_64.PACKED_ARITH	Counts number of SIMD integer 64 bit arithmetic operations.	
FDH	40H	SIMD_INT_64.SHUFFLE_MOVE	Counts number of SIMD integer 64 bit shift or move operations.	

Non-architectural Performance monitoring events of the uncore sub-system for Processors with CPUID signature of DisplayFamily\_DisplayModel 06\_25H, 06\_2CH, and 06\_1FH support performance events listed in Table 19-10.

**Table 19-10. Non-Architectural Performance Events In the Processor Uncore for Processors Based on Intel® Microarchitecture Code Name Westmere**

Event Num.	Umask Value	Event Mask Mnemonic	Description	Comment
00H	01H	UNC_GQ_CYCLES_FULL.READ_TRACKER	Uncore cycles Global Queue read tracker is full.	
00H	02H	UNC_GQ_CYCLES_FULL.WRITE_TRACKER	Uncore cycles Global Queue write tracker is full.	
00H	04H	UNC_GQ_CYCLES_FULL.PEER_PROBE_TRACKER	Uncore cycles Global Queue peer probe tracker is full. The peer probe tracker queue tracks snoops from the IOH and remote sockets.	
01H	01H	UNC_GQ_CYCLES_NOT_EMPTY.READ_TRACKER	Uncore cycles were Global Queue read tracker has at least one valid entry.	
01H	02H	UNC_GQ_CYCLES_NOT_EMPTY.WRITE_TRACKER	Uncore cycles were Global Queue write tracker has at least one valid entry.	
01H	04H	UNC_GQ_CYCLES_NOT_EMPTY.PEER_PROBE_TRACKER	Uncore cycles were Global Queue peer probe tracker has at least one valid entry. The peer probe tracker queue tracks IOH and remote socket snoops.	

**Table 19-10. Non-Architectural Performance Events In the Processor Uncore for Processors Based on Intel® Microarchitecture Code Name Westmere**

Event Num.	Umask Value	Event Mask Mnemonic	Description	Comment
02H	01H	UNC_GQ_OCCUPANCY.READ_TRACKER	Increments the number of queue entries (code read, data read, and RFOs) in the tread tracker. The GQ read tracker allocate to deallocate occupancy count is divided by the count to obtain the average read tracker latency.	
03H	01H	UNC_GQ_ALLOC.READ_TRACKER	Counts the number of tread tracker allocate to deallocate entries. The GQ read tracker allocate to deallocate occupancy count is divided by the count to obtain the average read tracker latency.	
03H	02H	UNC_GQ_ALLOC.RT_L3_MISS	Counts the number GQ read tracker entries for which a full cache line read has missed the L3. The GQ read tracker L3 miss to fill occupancy count is divided by this count to obtain the average cache line read L3 miss latency. The latency represents the time after which the L3 has determined that the cache line has missed. The time between a GQ read tracker allocation and the L3 determining that the cache line has missed is the average L3 hit latency. The total L3 cache line read miss latency is the hit latency + L3 miss latency.	
03H	04H	UNC_GQ_ALLOC.RT_TO_L3_RESP	Counts the number of GQ read tracker entries that are allocated in the read tracker queue that hit or miss the L3. The GQ read tracker L3 hit occupancy count is divided by this count to obtain the average L3 hit latency.	

**Table 19-10. Non-Architectural Performance Events In the Processor Uncore for Processors Based on Intel® Microarchitecture Code Name Westmere**

Event Num.	Umask Value	Event Mask Mnemonic	Description	Comment
03H	08H	UNC_GQ_ALLOC.RT_TO_RTID_ACQUIRED	Counts the number of GQ read tracker entries that are allocated in the read tracker, have missed in the L3 and have not acquired a Request Transaction ID. The GQ read tracker L3 miss to RTID acquired occupancy count is divided by this count to obtain the average latency for a read L3 miss to acquire an RTID.	
03H	10H	UNC_GQ_ALLOC.WT_TO_RTID_ACQUIRED	Counts the number of GQ write tracker entries that are allocated in the write tracker, have missed in the L3 and have not acquired a Request Transaction ID. The GQ write tracker L3 miss to RTID occupancy count is divided by this count to obtain the average latency for a write L3 miss to acquire an RTID.	
03H	20H	UNC_GQ_ALLOC.WRITE_TRACKER	Counts the number of GQ write tracker entries that are allocated in the write tracker queue that miss the L3. The GQ write tracker occupancy count is divided by the this count to obtain the average L3 write miss latency.	
03H	40H	UNC_GQ_ALLOC.PEER_PROBE_TRACKER	Counts the number of GQ peer probe tracker (snoop) entries that are allocated in the peer probe tracker queue that miss the L3. The GQ peer probe occupancy count is divided by this count to obtain the average L3 peer probe miss latency.	
04H	01H	UNC_GQ_DATA.FROM_QPI	Cycles Global Queue Quickpath Interface input data port is busy importing data from the Quickpath Interface. Each cycle the input port can transfer 8 or 16 bytes of data.	

**Table 19-10. Non-Architectural Performance Events In the Processor Uncore for Processors Based on Intel® Microarchitecture Code Name Westmere**

Event Num.	Umask Value	Event Mask Mnemonic	Description	Comment
04H	02H	UNC_GQ_DATA.FROM_QMC	Cycles Global Queue Quickpath Memory Interface input data port is busy importing data from the Quickpath Memory Interface. Each cycle the input port can transfer 8 or 16 bytes of data.	
04H	04H	UNC_GQ_DATA.FROM_L3	Cycles GQ L3 input data port is busy importing data from the Last Level Cache. Each cycle the input port can transfer 32 bytes of data.	
04H	08H	UNC_GQ_DATA.FROM_CORES_02	Cycles GQ Core 0 and 2 input data port is busy importing data from processor cores 0 and 2. Each cycle the input port can transfer 32 bytes of data.	
04H	10H	UNC_GQ_DATA.FROM_CORES_13	Cycles GQ Core 1 and 3 input data port is busy importing data from processor cores 1 and 3. Each cycle the input port can transfer 32 bytes of data.	
05H	01H	UNC_GQ_DATA.TO_QPI_QMC	Cycles GQ QPI and QMC output data port is busy sending data to the Quickpath Interface or Quickpath Memory Interface. Each cycle the output port can transfer 32 bytes of data.	
05H	02H	UNC_GQ_DATA.TO_L3	Cycles GQ L3 output data port is busy sending data to the Last Level Cache. Each cycle the output port can transfer 32 bytes of data.	
05H	04H	UNC_GQ_DATA.TO_CORES	Cycles GQ Core output data port is busy sending data to the Cores. Each cycle the output port can transfer 32 bytes of data.	
06H	01H	UNC_SNP_RESP_TO_LOCAL_HOME.I_STAT_E	Number of snoop responses to the local home that L3 does not have the referenced cache line.	



**Table 19-10. Non-Architectural Performance Events In the Processor Uncore for Processors Based on Intel® Microarchitecture Code Name Westmere**

Event Num.	Umask Value	Event Mask Mnemonic	Description	Comment
06H	02H	UNC_SNP_RESP_TO_LOCAL_HOME.S_STATE	Number of snoop responses to the local home that L3 has the referenced line cached in the S state.	
06H	04H	UNC_SNP_RESP_TO_LOCAL_HOME.FWD_S_STATE	Number of responses to code or data read snoops to the local home that the L3 has the referenced cache line in the E state. The L3 cache line state is changed to the S state and the line is forwarded to the local home in the S state.	
06H	08H	UNC_SNP_RESP_TO_LOCAL_HOME.FWD_I_STATE	Number of responses to read invalidate snoops to the local home that the L3 has the referenced cache line in the M state. The L3 cache line state is invalidated and the line is forwarded to the local home in the M state.	
06H	10H	UNC_SNP_RESP_TO_LOCAL_HOME.CONFLICT	Number of conflict snoop responses sent to the local home.	
06H	20H	UNC_SNP_RESP_TO_LOCAL_HOME.WB	Number of responses to code or data read snoops to the local home that the L3 has the referenced line cached in the M state.	
07H	01H	UNC_SNP_RESP_TO_REMOTE_HOME.I_STATE	Number of snoop responses to a remote home that L3 does not have the referenced cache line.	
07H	02H	UNC_SNP_RESP_TO_REMOTE_HOME.S_STATE	Number of snoop responses to a remote home that L3 has the referenced line cached in the S state.	
07H	04H	UNC_SNP_RESP_TO_REMOTE_HOME.FWD_S_STATE	Number of responses to code or data read snoops to a remote home that the L3 has the referenced cache line in the E state. The L3 cache line state is changed to the S state and the line is forwarded to the remote home in the S state.	

**Table 19-10. Non-Architectural Performance Events In the Processor Uncore for Processors Based on Intel® Microarchitecture Code Name Westmere**

Event Num.	Umask Value	Event Mask Mnemonic	Description	Comment
07H	08H	UNC_SNP_RESP_TO_REMOTE_HOME.FWD_I_STATE	Number of responses to read invalidate snoops to a remote home that the L3 has the referenced cache line in the M state. The L3 cache line state is invalidated and the line is forwarded to the remote home in the M state.	
07H	10H	UNC_SNP_RESP_TO_REMOTE_HOME.CONFLICT	Number of conflict snoop responses sent to the local home.	
07H	20H	UNC_SNP_RESP_TO_REMOTE_HOME.WB	Number of responses to code or data read snoops to a remote home that the L3 has the referenced line cached in the M state.	
07H	24H	UNC_SNP_RESP_TO_REMOTE_HOME.HITM	Number of HITM snoop responses to a remote home	
08H	01H	UNC_L3_HITS.READ	Number of code read, data read and RFO requests that hit in the L3	
08H	02H	UNC_L3_HITS.WRITE	Number of writeback requests that hit in the L3. Writebacks from the cores will always result in L3 hits due to the inclusive property of the L3.	
08H	04H	UNC_L3_HITS.PROBE	Number of snoops from IOH or remote sockets that hit in the L3.	
08H	03H	UNC_L3_HITS.ANY	Number of reads and writes that hit the L3.	
09H	01H	UNC_L3_MISS.READ	Number of code read, data read and RFO requests that miss the L3.	
09H	02H	UNC_L3_MISS.WRITE	Number of writeback requests that miss the L3. Should always be zero as writebacks from the cores will always result in L3 hits due to the inclusive property of the L3.	
09H	04H	UNC_L3_MISS.PROBE	Number of snoops from IOH or remote sockets that miss the L3.	
09H	03H	UNC_L3_MISS.ANY	Number of reads and writes that miss the L3.	

**Table 19-10. Non-Architectural Performance Events In the Processor Uncore for Processors Based on Intel® Microarchitecture Code Name Westmere**

Event Num.	Umask Value	Event Mask Mnemonic	Description	Comment
OAH	01H	UNC_L3_LINES_IN.M_STATE	Counts the number of L3 lines allocated in M state. The only time a cache line is allocated in the M state is when the line was forwarded in M state is forwarded due to a Snoop Read Invalidate Own request.	
OAH	02H	UNC_L3_LINES_IN.E_STATE	Counts the number of L3 lines allocated in E state.	
OAH	04H	UNC_L3_LINES_IN.S_STATE	Counts the number of L3 lines allocated in S state.	
OAH	08H	UNC_L3_LINES_IN.F_STATE	Counts the number of L3 lines allocated in F state.	
OAH	0FH	UNC_L3_LINES_IN.ANY	Counts the number of L3 lines allocated in any state.	
OBH	01H	UNC_L3_LINES_OUT.M_STATE	Counts the number of L3 lines victimized that were in the M state. When the victim cache line is in M state, the line is written to its home cache agent which can be either local or remote.	
OBH	02H	UNC_L3_LINES_OUT.E_STATE	Counts the number of L3 lines victimized that were in the E state.	
OBH	04H	UNC_L3_LINES_OUT.S_STATE	Counts the number of L3 lines victimized that were in the S state.	
OBH	08H	UNC_L3_LINES_OUT.I_STATE	Counts the number of L3 lines victimized that were in the I state.	
OBH	10H	UNC_L3_LINES_OUT.F_STATE	Counts the number of L3 lines victimized that were in the F state.	
OBH	1FH	UNC_L3_LINES_OUT.ANY	Counts the number of L3 lines victimized in any state.	
OCH	01H	UNC_GQ_SNOOP.GOTO_S	Counts the number of remote snoops that have requested a cache line be set to the S state.	
OCH	02H	UNC_GQ_SNOOP.GOTO_I	Counts the number of remote snoops that have requested a cache line be set to the I state.	

**Table 19-10. Non-Architectural Performance Events In the Processor Uncore for Processors Based on Intel® Microarchitecture Code Name Westmere**

Event Num.	Umask Value	Event Mask Mnemonic	Description	Comment
0CH	04H	UNC_GQ_SNOOP.GOT O_S_HIT_E	Counts the number of remote snoops that have requested a cache line be set to the S state from E state.	Requires writing MSR 301H with mask = 2H
0CH	04H	UNC_GQ_SNOOP.GOT O_S_HIT_F	Counts the number of remote snoops that have requested a cache line be set to the S state from F (forward) state.	Requires writing MSR 301H with mask = 8H
0CH	04H	UNC_GQ_SNOOP.GOT O_S_HIT_M	Counts the number of remote snoops that have requested a cache line be set to the S state from M state.	Requires writing MSR 301H with mask = 1H
0CH	04H	UNC_GQ_SNOOP.GOT O_S_HIT_S	Counts the number of remote snoops that have requested a cache line be set to the S state from S state.	Requires writing MSR 301H with mask = 4H
0CH	08H	UNC_GQ_SNOOP.GOT O_I_HIT_E	Counts the number of remote snoops that have requested a cache line be set to the I state from E state.	Requires writing MSR 301H with mask = 2H
0CH	08H	UNC_GQ_SNOOP.GOT O_I_HIT_F	Counts the number of remote snoops that have requested a cache line be set to the I state from F (forward) state.	Requires writing MSR 301H with mask = 8H
0CH	08H	UNC_GQ_SNOOP.GOT O_I_HIT_M	Counts the number of remote snoops that have requested a cache line be set to the I state from M state.	Requires writing MSR 301H with mask = 1H
0CH	08H	UNC_GQ_SNOOP.GOT O_I_HIT_S	Counts the number of remote snoops that have requested a cache line be set to the I state from S state.	Requires writing MSR 301H with mask = 4H
20H	01H	UNC_QHL_REQUEST S.IOH_READS	Counts number of Quickpath Home Logic read requests from the IOH.	
20H	02H	UNC_QHL_REQUEST S.IOH_WRITES	Counts number of Quickpath Home Logic write requests from the IOH.	
20H	04H	UNC_QHL_REQUEST S.REMOTE_READS	Counts number of Quickpath Home Logic read requests from a remote socket.	

**Table 19-10. Non-Architectural Performance Events In the Processor Uncore for Processors Based on Intel® Microarchitecture Code Name Westmere**

Event Num.	Umask Value	Event Mask Mnemonic	Description	Comment
20H	08H	UNC_QHL_REQUEST S.REMOTE_WRITES	Counts number of Quickpath Home Logic write requests from a remote socket.	
20H	10H	UNC_QHL_REQUEST S.LOCAL_READS	Counts number of Quickpath Home Logic read requests from the local socket.	
20H	20H	UNC_QHL_REQUEST S.LOCAL_WRITES	Counts number of Quickpath Home Logic write requests from the local socket.	
21H	01H	UNC_QHL_CYCLES_F ULL.IOH	Counts uclk cycles all entries in the Quickpath Home Logic IOH are full.	
21H	02H	UNC_QHL_CYCLES_F ULL.REMOTE	Counts uclk cycles all entries in the Quickpath Home Logic remote tracker are full.	
21H	04H	UNC_QHL_CYCLES_F ULL.LOCAL	Counts uclk cycles all entries in the Quickpath Home Logic local tracker are full.	
22H	01H	UNC_QHL_CYCLES_N OT_EMPTY.IOH	Counts uclk cycles all entries in the Quickpath Home Logic IOH is busy.	
22H	02H	UNC_QHL_CYCLES_N OT_EMPTY.REMOTE	Counts uclk cycles all entries in the Quickpath Home Logic remote tracker is busy.	
22H	04H	UNC_QHL_CYCLES_N OT_EMPTY.LOCAL	Counts uclk cycles all entries in the Quickpath Home Logic local tracker is busy.	
23H	01H	UNC_QHL_OCCUPAN CY.IOH	QHL IOH tracker allocate to deallocate read occupancy.	
23H	02H	UNC_QHL_OCCUPAN CY.REMOTE	QHL remote tracker allocate to deallocate read occupancy.	
23H	04H	UNC_QHL_OCCUPAN CY.LOCAL	QHL local tracker allocate to deallocate read occupancy.	

**Table 19-10. Non-Architectural Performance Events In the Processor Uncore for Processors Based on Intel® Microarchitecture Code Name Westmere**

Event Num.	Umask Value	Event Mask Mnemonic	Description	Comment
24H	02H	UNC_QHL_ADDRESS_CONFLICTS.2WAY	Counts number of QHL Active Address Table (AAT) entries that saw a max of 2 conflicts. The AAT is a structure that tracks requests that are in conflict. The requests themselves are in the home tracker entries. The count is reported when an AAT entry deallocates.	
24H	04H	UNC_QHL_ADDRESS_CONFLICTS.3WAY	Counts number of QHL Active Address Table (AAT) entries that saw a max of 3 conflicts. The AAT is a structure that tracks requests that are in conflict. The requests themselves are in the home tracker entries. The count is reported when an AAT entry deallocates.	
25H	01H	UNC_QHL_CONFLICT_CYCLES.IOH	Counts cycles the Quickpath Home Logic IOH Tracker contains two or more requests with an address conflict. A max of 3 requests can be in conflict.	
25H	02H	UNC_QHL_CONFLICT_CYCLES.REMOTE	Counts cycles the Quickpath Home Logic Remote Tracker contains two or more requests with an address conflict. A max of 3 requests can be in conflict.	
25H	04H	UNC_QHL_CONFLICT_CYCLES.LOCAL	Counts cycles the Quickpath Home Logic Local Tracker contains two or more requests with an address conflict. A max of 3 requests can be in conflict.	
26H	01H	UNC_QHL_TO_QMC_BYPASS	Counts number of requests to the Quickpath Memory Controller that bypass the Quickpath Home Logic. All local accesses can be bypassed. For remote requests, only read requests can be bypassed.	

**Table 19-10. Non-Architectural Performance Events In the Processor Uncore for Processors Based on Intel® Microarchitecture Code Name Westmere**

Event Num.	Umask Value	Event Mask Mnemonic	Description	Comment
28H	01H	UNC_QMC_ISOC_FUL L.READ.CH0	Counts cycles all the entries in the DRAM channel 0 high priority queue are occupied with isochronous read requests.	
28H	02H	UNC_QMC_ISOC_FUL L.READ.CH1	Counts cycles all the entries in the DRAM channel 1 high priority queue are occupied with isochronous read requests.	
28H	04H	UNC_QMC_ISOC_FUL L.READ.CH2	Counts cycles all the entries in the DRAM channel 2 high priority queue are occupied with isochronous read requests.	
28H	08H	UNC_QMC_ISOC_FUL L.WRITE.CH0	Counts cycles all the entries in the DRAM channel 0 high priority queue are occupied with isochronous write requests.	
28H	10H	UNC_QMC_ISOC_FUL L.WRITE.CH1	Counts cycles all the entries in the DRAM channel 1 high priority queue are occupied with isochronous write requests.	
28H	20H	UNC_QMC_ISOC_FUL L.WRITE.CH2	Counts cycles all the entries in the DRAM channel 2 high priority queue are occupied with isochronous write requests.	
29H	01H	UNC_QMC_BUSY.REA D.CH0	Counts cycles where Quickpath Memory Controller has at least 1 outstanding read request to DRAM channel 0.	
29H	02H	UNC_QMC_BUSY.REA D.CH1	Counts cycles where Quickpath Memory Controller has at least 1 outstanding read request to DRAM channel 1.	
29H	04H	UNC_QMC_BUSY.REA D.CH2	Counts cycles where Quickpath Memory Controller has at least 1 outstanding read request to DRAM channel 2.	

**Table 19-10. Non-Architectural Performance Events In the Processor Uncore for Processors Based on Intel® Microarchitecture Code Name Westmere**

Event Num.	Umask Value	Event Mask Mnemonic	Description	Comment
29H	08H	UNC_QMC_BUSY.WRITE.CH0	Counts cycles where Quickpath Memory Controller has at least 1 outstanding write request to DRAM channel 0.	
29H	10H	UNC_QMC_BUSY.WRITE.CH1	Counts cycles where Quickpath Memory Controller has at least 1 outstanding write request to DRAM channel 1.	
29H	20H	UNC_QMC_BUSY.WRITE.CH2	Counts cycles where Quickpath Memory Controller has at least 1 outstanding write request to DRAM channel 2.	
2AH	01H	UNC_QMC_OCCUPANCY.CH0	IMC channel 0 normal read request occupancy.	
2AH	02H	UNC_QMC_OCCUPANCY.CH1	IMC channel 1 normal read request occupancy.	
2AH	04H	UNC_QMC_OCCUPANCY.CH2	IMC channel 2 normal read request occupancy.	
2AH	07H	UNC_QMC_OCCUPANCY.ANY	Normal read request occupancy for any channel.	
2BH	01H	UNC_QMC_ISSOC_OCCUPANCY.CH0	IMC channel 0 issoc read request occupancy.	
2BH	02H	UNC_QMC_ISSOC_OCCUPANCY.CH1	IMC channel 1 issoc read request occupancy.	
2BH	04H	UNC_QMC_ISSOC_OCCUPANCY.CH2	IMC channel 2 issoc read request occupancy.	
2BH	07H	UNC_QMC_ISSOC_READS.ANY	IMC issoc read request occupancy.	
2CH	01H	UNC_QMC_NORMAL_READS.CH0	Counts the number of Quickpath Memory Controller channel 0 medium and low priority read requests. The QMC channel 0 normal read occupancy divided by this count provides the average QMC channel 0 read latency.	



**Table 19-10. Non-Architectural Performance Events In the Processor Uncore for Processors Based on Intel® Microarchitecture Code Name Westmere**

Event Num.	Umask Value	Event Mask Mnemonic	Description	Comment
2CH	02H	UNC_QMC_NORMAL_READS.CH1	Counts the number of Quickpath Memory Controller channel 1 medium and low priority read requests. The QMC channel 1 normal read occupancy divided by this count provides the average QMC channel 1 read latency.	
2CH	04H	UNC_QMC_NORMAL_READS.CH2	Counts the number of Quickpath Memory Controller channel 2 medium and low priority read requests. The QMC channel 2 normal read occupancy divided by this count provides the average QMC channel 2 read latency.	
2CH	07H	UNC_QMC_NORMAL_READS.ANY	Counts the number of Quickpath Memory Controller medium and low priority read requests. The QMC normal read occupancy divided by this count provides the average QMC read latency.	
2DH	01H	UNC_QMC_HIGH_PRIORITY_READS.CH0	Counts the number of Quickpath Memory Controller channel 0 high priority isochronous read requests.	
2DH	02H	UNC_QMC_HIGH_PRIORITY_READS.CH1	Counts the number of Quickpath Memory Controller channel 1 high priority isochronous read requests.	
2DH	04H	UNC_QMC_HIGH_PRIORITY_READS.CH2	Counts the number of Quickpath Memory Controller channel 2 high priority isochronous read requests.	
2DH	07H	UNC_QMC_HIGH_PRIORITY_READS.ANY	Counts the number of Quickpath Memory Controller high priority isochronous read requests.	
2EH	01H	UNC_QMC_CRITICAL_PRIORITY_READS.CH0	Counts the number of Quickpath Memory Controller channel 0 critical priority isochronous read requests.	
2EH	02H	UNC_QMC_CRITICAL_PRIORITY_READS.CH1	Counts the number of Quickpath Memory Controller channel 1 critical priority isochronous read requests.	

**Table 19-10. Non-Architectural Performance Events In the Processor Uncore for Processors Based on Intel® Microarchitecture Code Name Westmere**

Event Num.	Umask Value	Event Mask Mnemonic	Description	Comment
2EH	04H	UNC_QMC_CRITICAL_PRIORITY_READS.CH2	Counts the number of Quickpath Memory Controller channel 2 critical priority isochronous read requests.	
2EH	07H	UNC_QMC_CRITICAL_PRIORITY_READS.ANY	Counts the number of Quickpath Memory Controller critical priority isochronous read requests.	
2FH	01H	UNC_QMC_WRITES.FULL.CH0	Counts number of full cache line writes to DRAM channel 0.	
2FH	02H	UNC_QMC_WRITES.FULL.CH1	Counts number of full cache line writes to DRAM channel 1.	
2FH	04H	UNC_QMC_WRITES.FULL.CH2	Counts number of full cache line writes to DRAM channel 2.	
2FH	07H	UNC_QMC_WRITES.FULL.ANY	Counts number of full cache line writes to DRAM.	
2FH	08H	UNC_QMC_WRITES.PARTIAL.CH0	Counts number of partial cache line writes to DRAM channel 0.	
2FH	10H	UNC_QMC_WRITES.PARTIAL.CH1	Counts number of partial cache line writes to DRAM channel 1.	
2FH	20H	UNC_QMC_WRITES.PARTIAL.CH2	Counts number of partial cache line writes to DRAM channel 2.	
2FH	38H	UNC_QMC_WRITES.PARTIAL.ANY	Counts number of partial cache line writes to DRAM.	
30H	01H	UNC_QMC_CANCEL.CH0	Counts number of DRAM channel 0 cancel requests.	
30H	02H	UNC_QMC_CANCEL.CH1	Counts number of DRAM channel 1 cancel requests.	
30H	04H	UNC_QMC_CANCEL.CH2	Counts number of DRAM channel 2 cancel requests.	
30H	07H	UNC_QMC_CANCEL.ANY	Counts number of DRAM cancel requests.	

**Table 19-10. Non-Architectural Performance Events In the Processor Uncore for Processors Based on Intel® Microarchitecture Code Name Westmere**

Event Num.	Umask Value	Event Mask Mnemonic	Description	Comment
31H	01H	UNC_QMC_PRIORITY_UPDATES.CHO	Counts number of DRAM channel 0 priority updates. A priority update occurs when an ISOC high or critical request is received by the QHL and there is a matching request with normal priority that has already been issued to the QMC. In this instance, the QHL will send a priority update to QMC to expedite the request.	
31H	02H	UNC_QMC_PRIORITY_UPDATES.CH1	Counts number of DRAM channel 1 priority updates. A priority update occurs when an ISOC high or critical request is received by the QHL and there is a matching request with normal priority that has already been issued to the QMC. In this instance, the QHL will send a priority update to QMC to expedite the request.	
31H	04H	UNC_QMC_PRIORITY_UPDATES.CH2	Counts number of DRAM channel 2 priority updates. A priority update occurs when an ISOC high or critical request is received by the QHL and there is a matching request with normal priority that has already been issued to the QMC. In this instance, the QHL will send a priority update to QMC to expedite the request.	
31H	07H	UNC_QMC_PRIORITY_UPDATES.ANY	Counts number of DRAM priority updates. A priority update occurs when an ISOC high or critical request is received by the QHL and there is a matching request with normal priority that has already been issued to the QMC. In this instance, the QHL will send a priority update to QMC to expedite the request.	
32H	01H	UNC_IMC_RETRY.CH0	Counts number of IMC DRAM channel 0 retries. DRAM retry only occurs when configured in RAS mode.	

**Table 19-10. Non-Architectural Performance Events In the Processor Uncore for Processors Based on Intel® Microarchitecture Code Name Westmere**

Event Num.	Umask Value	Event Mask Mnemonic	Description	Comment
32H	02H	UNC_IMC_RETRY.CH1	Counts number of IMC DRAM channel 1 retries. DRAM retry only occurs when configured in RAS mode.	
32H	04H	UNC_IMC_RETRY.CH2	Counts number of IMC DRAM channel 2 retries. DRAM retry only occurs when configured in RAS mode.	
32H	07H	UNC_IMC_RETRY.ANY	Counts number of IMC DRAM retries from any channel. DRAM retry only occurs when configured in RAS mode.	
33H	01H	UNC_QHL_FRC_ACK_CNFLTS.IOH	Counts number of Force Acknowledge Conflict messages sent by the Quickpath Home Logic to the IOH.	
33H	02H	UNC_QHL_FRC_ACK_CNFLTS.REMOTE	Counts number of Force Acknowledge Conflict messages sent by the Quickpath Home Logic to the remote home.	
33H	04H	UNC_QHL_FRC_ACK_CNFLTS.LOCAL	Counts number of Force Acknowledge Conflict messages sent by the Quickpath Home Logic to the local home.	
33H	07H	UNC_QHL_FRC_ACK_CNFLTS.ANY	Counts number of Force Acknowledge Conflict messages sent by the Quickpath Home Logic.	
34H	01H	UNC_QHL_SLEEPS.IOH_ORDER	Counts number of occurrences a request was put to sleep due to IOH ordering (write after read) conflicts. While in the sleep state, the request is not eligible to be scheduled to the QMC.	
34H	02H	UNC_QHL_SLEEPS.REMOTE_ORDER	Counts number of occurrences a request was put to sleep due to remote socket ordering (write after read) conflicts. While in the sleep state, the request is not eligible to be scheduled to the QMC.	

**Table 19-10. Non-Architectural Performance Events In the Processor Uncore for Processors Based on Intel® Microarchitecture Code Name Westmere**

Event Num.	Umask Value	Event Mask Mnemonic	Description	Comment
34H	04H	UNC_QHL_SLEEPS.L OCAL_ORDER	Counts number of occurrences a request was put to sleep due to local socket ordering (write after read) conflicts. While in the sleep state, the request is not eligible to be scheduled to the QMC.	
34H	08H	UNC_QHL_SLEEPS.IO H_CONFLICT	Counts number of occurrences a request was put to sleep due to IOH address conflicts. While in the sleep state, the request is not eligible to be scheduled to the QMC.	
34H	10H	UNC_QHL_SLEEPS.R EMOTE_CONFLICT	Counts number of occurrences a request was put to sleep due to remote socket address conflicts. While in the sleep state, the request is not eligible to be scheduled to the QMC.	
34H	20H	UNC_QHL_SLEEPS.L OCAL_CONFLICT	Counts number of occurrences a request was put to sleep due to local socket address conflicts. While in the sleep state, the request is not eligible to be scheduled to the QMC.	
35H	01H	UNC_ADDR_OPCODE _MATCH.IOH	Counts number of requests from the IOH, address/opcode of request is qualified by mask value written to MSR 396H. The following mask values are supported:  0: NONE 40000000_00000000H:RSPFWDI 40001A00_00000000H:RSPFWDS 40001D00_00000000H:RSPIWB	Match opcode/addresses by writing MSR 396H with mask supported mask value

**Table 19-10. Non-Architectural Performance Events In the Processor Uncore for Processors Based on Intel® Microarchitecture Code Name Westmere**

Event Num.	Umask Value	Event Mask Mnemonic	Description	Comment
35H	02H	UNC_ADDR_OPCODE_MATCH.REMOTE	Counts number of requests from the remote socket, address/opcode of request is qualified by mask value written to MSR 396H. The following mask values are supported: 0: NONE 40000000_00000000H:RSPFWDI 40001A00_00000000H:RSPFWDS 40001D00_00000000H:RSPiWB	Match opcode/addresses by writing MSR 396H with mask supported mask value
35H	04H	UNC_ADDR_OPCODE_MATCH.LOCAL	Counts number of requests from the local socket, address/opcode of request is qualified by mask value written to MSR 396H. The following mask values are supported: 0: NONE 40000000_00000000H:RSPFWDI 40001A00_00000000H:RSPFWDS 40001D00_00000000H:RSPiWB	Match opcode/addresses by writing MSR 396H with mask supported mask value
40H	01H	UNC_QPI_TX_STALLED_SINGLE_FLIT.HOME.LINK_0	Counts cycles the Quickpath outbound link 0 HOME virtual channel is stalled due to lack of a VNA and VNO credit. Note that this event does not filter out when a flit would not have been selected for arbitration because another virtual channel is getting arbitrated.	
40H	02H	UNC_QPI_TX_STALLED_SINGLE_FLIT.SNOOP.LINK_0	Counts cycles the Quickpath outbound link 0 SNOOP virtual channel is stalled due to lack of a VNA and VNO credit. Note that this event does not filter out when a flit would not have been selected for arbitration because another virtual channel is getting arbitrated.	

**Table 19-10. Non-Architectural Performance Events In the Processor Uncore for Processors Based on Intel® Microarchitecture Code Name Westmere**

Event Num.	Umask Value	Event Mask Mnemonic	Description	Comment
40H	04H	UNC_QPI_TX_STALL ED_SINGLE_FLIT.NDR .LINK_0	Counts cycles the Quickpath outbound link 0 non-data response virtual channel is stalled due to lack of a VNA and VNO credit. Note that this event does not filter out when a flit would not have been selected for arbitration because another virtual channel is getting arbitrated.	
40H	08H	UNC_QPI_TX_STALL ED_SINGLE_FLIT.HO ME.LINK_1	Counts cycles the Quickpath outbound link 1 HOME virtual channel is stalled due to lack of a VNA and VNO credit. Note that this event does not filter out when a flit would not have been selected for arbitration because another virtual channel is getting arbitrated.	
40H	10H	UNC_QPI_TX_STALL ED_SINGLE_FLIT.SNO OP.LINK_1	Counts cycles the Quickpath outbound link 1 SNOOP virtual channel is stalled due to lack of a VNA and VNO credit. Note that this event does not filter out when a flit would not have been selected for arbitration because another virtual channel is getting arbitrated.	
40H	20H	UNC_QPI_TX_STALL ED_SINGLE_FLIT.NDR .LINK_1	Counts cycles the Quickpath outbound link 1 non-data response virtual channel is stalled due to lack of a VNA and VNO credit. Note that this event does not filter out when a flit would not have been selected for arbitration because another virtual channel is getting arbitrated.	
40H	07H	UNC_QPI_TX_STALL ED_SINGLE_FLIT.LIN K_0	Counts cycles the Quickpath outbound link 0 virtual channels are stalled due to lack of a VNA and VNO credit. Note that this event does not filter out when a flit would not have been selected for arbitration because another virtual channel is getting arbitrated.	

**Table 19-10. Non-Architectural Performance Events In the Processor Uncore for Processors Based on Intel® Microarchitecture Code Name Westmere**

Event Num.	Umask Value	Event Mask Mnemonic	Description	Comment
40H	38H	UNC_QPI_TX_STALL ED_SINGLE_FLIT.LINK_1	Counts cycles the Quickpath outbound link 1 virtual channels are stalled due to lack of a VNA and VNO credit. Note that this event does not filter out when a flit would not have been selected for arbitration because another virtual channel is getting arbitrated.	
41H	01H	UNC_QPI_TX_STALL ED_MULTI_FLIT.DRS.LINK_0	Counts cycles the Quickpath outbound link 0 Data ResponSe virtual channel is stalled due to lack of VNA and VNO credits. Note that this event does not filter out when a flit would not have been selected for arbitration because another virtual channel is getting arbitrated.	
41H	02H	UNC_QPI_TX_STALL ED_MULTI_FLIT.NCB.LINK_0	Counts cycles the Quickpath outbound link 0 Non-Coherent Bypass virtual channel is stalled due to lack of VNA and VNO credits. Note that this event does not filter out when a flit would not have been selected for arbitration because another virtual channel is getting arbitrated.	
41H	04H	UNC_QPI_TX_STALL ED_MULTI_FLIT.NCS.LINK_0	Counts cycles the Quickpath outbound link 0 Non-Coherent Standard virtual channel is stalled due to lack of VNA and VNO credits. Note that this event does not filter out when a flit would not have been selected for arbitration because another virtual channel is getting arbitrated.	
41H	08H	UNC_QPI_TX_STALL ED_MULTI_FLIT.DRS.LINK_1	Counts cycles the Quickpath outbound link 1 Data ResponSe virtual channel is stalled due to lack of VNA and VNO credits. Note that this event does not filter out when a flit would not have been selected for arbitration because another virtual channel is getting arbitrated.	



**Table 19-10. Non-Architectural Performance Events In the Processor Uncore for Processors Based on Intel® Microarchitecture Code Name Westmere**

Event Num.	Umask Value	Event Mask Mnemonic	Description	Comment
41H	10H	UNC_QPI_TX_STALL ED_MULTI_FLIT.NCB. LINK_1	Counts cycles the Quickpath outbound link 1 Non-Coherent Bypass virtual channel is stalled due to lack of VNA and VNO credits. Note that this event does not filter out when a flit would not have been selected for arbitration because another virtual channel is getting arbitrated.	
41H	20H	UNC_QPI_TX_STALL ED_MULTI_FLIT.NCS. LINK_1	Counts cycles the Quickpath outbound link 1 Non-Coherent Standard virtual channel is stalled due to lack of VNA and VNO credits. Note that this event does not filter out when a flit would not have been selected for arbitration because another virtual channel is getting arbitrated.	
41H	07H	UNC_QPI_TX_STALL ED_MULTI_FLIT.LINK _0	Counts cycles the Quickpath outbound link 0 virtual channels are stalled due to lack of VNA and VNO credits. Note that this event does not filter out when a flit would not have been selected for arbitration because another virtual channel is getting arbitrated.	
41H	38H	UNC_QPI_TX_STALL ED_MULTI_FLIT.LINK _1	Counts cycles the Quickpath outbound link 1 virtual channels are stalled due to lack of VNA and VNO credits. Note that this event does not filter out when a flit would not have been selected for arbitration because another virtual channel is getting arbitrated.	
42H	01H	UNC_QPI_TX_HEADE R.FULL.LINK_0	Number of cycles that the header buffer in the Quickpath Interface outbound link 0 is full.	
42H	02H	UNC_QPI_TX_HEADE R.BUSY.LINK_0	Number of cycles that the header buffer in the Quickpath Interface outbound link 0 is busy.	

**Table 19-10. Non-Architectural Performance Events In the Processor Uncore for Processors Based on Intel® Microarchitecture Code Name Westmere**

Event Num.	Umask Value	Event Mask Mnemonic	Description	Comment
42H	04H	UNC_QPI_TX_HEADE R.FULL.LINK_1	Number of cycles that the header buffer in the Quickpath Interface outbound link 1 is full.	
42H	08H	UNC_QPI_TX_HEADE R.BUSY.LINK_1	Number of cycles that the header buffer in the Quickpath Interface outbound link 1 is busy.	
43H	01H	UNC_QPI_RX_NO_PP T_CREDIT.STALLS.LIN K_0	Number of cycles that snoop packets incoming to the Quickpath Interface link 0 are stalled and not sent to the GQ because the GQ Peer Probe Tracker (PPT) does not have any available entries.	
43H	02H	UNC_QPI_RX_NO_PP T_CREDIT.STALLS.LIN K_1	Number of cycles that snoop packets incoming to the Quickpath Interface link 1 are stalled and not sent to the GQ because the GQ Peer Probe Tracker (PPT) does not have any available entries.	
60H	01H	UNC_DRAM_OPEN.C H0	Counts number of DRAM Channel 0 open commands issued either for read or write. To read or write data, the referenced DRAM page must first be opened.	
60H	02H	UNC_DRAM_OPEN.C H1	Counts number of DRAM Channel 1 open commands issued either for read or write. To read or write data, the referenced DRAM page must first be opened.	
60H	04H	UNC_DRAM_OPEN.C H2	Counts number of DRAM Channel 2 open commands issued either for read or write. To read or write data, the referenced DRAM page must first be opened.	
61H	01H	UNC_DRAM_PAGE_C LOSE.CHO	DRAM channel 0 command issued to CLOSE a page due to page idle timer expiration. Closing a page is done by issuing a precharge.	

**Table 19-10. Non-Architectural Performance Events In the Processor Uncore for Processors Based on Intel® Microarchitecture Code Name Westmere**

Event Num.	Umask Value	Event Mask Mnemonic	Description	Comment
61H	02H	UNC_DRAM_PAGE_CLOSE.CH1	DRAM channel 1 command issued to CLOSE a page due to page idle timer expiration. Closing a page is done by issuing a precharge.	
61H	04H	UNC_DRAM_PAGE_CLOSE.CH2	DRAM channel 2 command issued to CLOSE a page due to page idle timer expiration. Closing a page is done by issuing a precharge.	
62H	01H	UNC_DRAM_PAGE_MISS.CH0	Counts the number of precharges (PRE) that were issued to DRAM channel 0 because there was a page miss. A page miss refers to a situation in which a page is currently open and another page from the same bank needs to be opened. The new page experiences a page miss. Closing of the old page is done by issuing a precharge.	
62H	02H	UNC_DRAM_PAGE_MISS.CH1	Counts the number of precharges (PRE) that were issued to DRAM channel 1 because there was a page miss. A page miss refers to a situation in which a page is currently open and another page from the same bank needs to be opened. The new page experiences a page miss. Closing of the old page is done by issuing a precharge.	
62H	04H	UNC_DRAM_PAGE_MISS.CH2	Counts the number of precharges (PRE) that were issued to DRAM channel 2 because there was a page miss. A page miss refers to a situation in which a page is currently open and another page from the same bank needs to be opened. The new page experiences a page miss. Closing of the old page is done by issuing a precharge.	
63H	01H	UNC_DRAM_READ_CAS.CH0	Counts the number of times a read CAS command was issued on DRAM channel 0.	

**Table 19-10. Non-Architectural Performance Events In the Processor Uncore for Processors Based on Intel® Microarchitecture Code Name Westmere**

Event Num.	Umask Value	Event Mask Mnemonic	Description	Comment
63H	02H	UNC_DRAM_READ_CAS.AUTOPRE_CH0	Counts the number of times a read CAS command was issued on DRAM channel 0 where the command issued used the auto-precharge (auto page close) mode.	
63H	04H	UNC_DRAM_READ_CAS.CH1	Counts the number of times a read CAS command was issued on DRAM channel 1.	
63H	08H	UNC_DRAM_READ_CAS.AUTOPRE_CH1	Counts the number of times a read CAS command was issued on DRAM channel 1 where the command issued used the auto-precharge (auto page close) mode.	
63H	10H	UNC_DRAM_READ_CAS.CH2	Counts the number of times a read CAS command was issued on DRAM channel 2.	
63H	20H	UNC_DRAM_READ_CAS.AUTOPRE_CH2	Counts the number of times a read CAS command was issued on DRAM channel 2 where the command issued used the auto-precharge (auto page close) mode.	
64H	01H	UNC_DRAM_WRITE_CAS.CH0	Counts the number of times a write CAS command was issued on DRAM channel 0.	
64H	02H	UNC_DRAM_WRITE_CAS.AUTOPRE_CH0	Counts the number of times a write CAS command was issued on DRAM channel 0 where the command issued used the auto-precharge (auto page close) mode.	
64H	04H	UNC_DRAM_WRITE_CAS.CH1	Counts the number of times a write CAS command was issued on DRAM channel 1.	
64H	08H	UNC_DRAM_WRITE_CAS.AUTOPRE_CH1	Counts the number of times a write CAS command was issued on DRAM channel 1 where the command issued used the auto-precharge (auto page close) mode.	

**Table 19-10. Non-Architectural Performance Events In the Processor Uncore for Processors Based on Intel® Microarchitecture Code Name Westmere**

Event Num.	Umask Value	Event Mask Mnemonic	Description	Comment
64H	10H	UNC_DRAM_WRITE_CAS.CH2	Counts the number of times a write CAS command was issued on DRAM channel 2.	
64H	20H	UNC_DRAM_WRITE_CAS.AUTOPRE_CH2	Counts the number of times a write CAS command was issued on DRAM channel 2 where the command issued used the auto-precharge (auto page close) mode.	
65H	01H	UNC_DRAM_REFRES H.CH0	Counts number of DRAM channel 0 refresh commands. DRAM loses data content over time. In order to keep correct data content, the data values have to be refreshed periodically.	
65H	02H	UNC_DRAM_REFRES H.CH1	Counts number of DRAM channel 1 refresh commands. DRAM loses data content over time. In order to keep correct data content, the data values have to be refreshed periodically.	
65H	04H	UNC_DRAM_REFRES H.CH2	Counts number of DRAM channel 2 refresh commands. DRAM loses data content over time. In order to keep correct data content, the data values have to be refreshed periodically.	
66H	01H	UNC_DRAM_PRE_AL L.CH0	Counts number of DRAM Channel 0 precharge-all (PREALL) commands that close all open pages in a rank. PREALL is issued when the DRAM needs to be refreshed or needs to go into a power down mode.	
66H	02H	UNC_DRAM_PRE_AL L.CH1	Counts number of DRAM Channel 1 precharge-all (PREALL) commands that close all open pages in a rank. PREALL is issued when the DRAM needs to be refreshed or needs to go into a power down mode.	

**Table 19-10. Non-Architectural Performance Events In the Processor Uncore for Processors Based on Intel® Microarchitecture Code Name Westmere**

Event Num.	Umask Value	Event Mask Mnemonic	Description	Comment
66H	04H	UNC_DRAM_PRE_AL L.CH2	Counts number of DRAM Channel 2 precharge-all (PREALL) commands that close all open pages in a rank. PREALL is issued when the DRAM needs to be refreshed or needs to go into a power down mode.	
67H	01H	UNC_DRAM_THERM AL_THROTTLED	Uncore cycles DRAM was throttled due to its temperature being above the thermal throttling threshold.	
80H	01H	UNC_THERMAL_THR OTTILING_TEMP.CORE _0	Cycles that the PCU records that core 0 is above the thermal throttling threshold temperature.	
80H	02H	UNC_THERMAL_THR OTTILING_TEMP.CORE _1	Cycles that the PCU records that core 1 is above the thermal throttling threshold temperature.	
80H	04H	UNC_THERMAL_THR OTTILING_TEMP.CORE _2	Cycles that the PCU records that core 2 is above the thermal throttling threshold temperature.	
80H	08H	UNC_THERMAL_THR OTTILING_TEMP.CORE _3	Cycles that the PCU records that core 3 is above the thermal throttling threshold temperature.	
81H	01H	UNC_THERMAL_THR OTTLED_TEMP.CORE _0	Cycles that the PCU records that core 0 is in the power throttled state due to core's temperature being above the thermal throttling threshold.	
81H	02H	UNC_THERMAL_THR OTTLED_TEMP.CORE _1	Cycles that the PCU records that core 1 is in the power throttled state due to core's temperature being above the thermal throttling threshold.	
81H	04H	UNC_THERMAL_THR OTTLED_TEMP.CORE _2	Cycles that the PCU records that core 2 is in the power throttled state due to core's temperature being above the thermal throttling threshold.	
81H	08H	UNC_THERMAL_THR OTTLED_TEMP.CORE _3	Cycles that the PCU records that core 3 is in the power throttled state due to core's temperature being above the thermal throttling threshold.	

**Table 19-10. Non-Architectural Performance Events In the Processor Uncore for Processors Based on Intel® Microarchitecture Code Name Westmere**

Event Num.	Umask Value	Event Mask Mnemonic	Description	Comment
82H	01H	UNC_PROCHOT_ASSERTION	Number of system assertions of PROCHOT indicating the entire processor has exceeded the thermal limit.	
83H	01H	UNC_THERMAL_THROTTLING_PROCHOT.CORE_0	Cycles that the PCU records that core 0 is a low power state due to the system asserting PROCHOT the entire processor has exceeded the thermal limit.	
83H	02H	UNC_THERMAL_THROTTLING_PROCHOT.CORE_1	Cycles that the PCU records that core 1 is a low power state due to the system asserting PROCHOT the entire processor has exceeded the thermal limit.	
83H	04H	UNC_THERMAL_THROTTLING_PROCHOT.CORE_2	Cycles that the PCU records that core 2 is a low power state due to the system asserting PROCHOT the entire processor has exceeded the thermal limit.	
83H	08H	UNC_THERMAL_THROTTLING_PROCHOT.CORE_3	Cycles that the PCU records that core 3 is a low power state due to the system asserting PROCHOT the entire processor has exceeded the thermal limit.	
84H	01H	UNC_TURBO_MODE.CORE_0	Uncore cycles that core 0 is operating in turbo mode.	
84H	02H	UNC_TURBO_MODE.CORE_1	Uncore cycles that core 1 is operating in turbo mode.	
84H	04H	UNC_TURBO_MODE.CORE_2	Uncore cycles that core 2 is operating in turbo mode.	
84H	08H	UNC_TURBO_MODE.CORE_3	Uncore cycles that core 3 is operating in turbo mode.	
85H	02H	UNC_CYCLES_UNHALTED_L3_FLL_ENABLED	Uncore cycles that at least one core is unhalted and all L3 ways are enabled.	
86H	01H	UNC_CYCLES_UNHALTED_L3_FLL_DISABLED	Uncore cycles that at least one core is unhalted and all L3 ways are disabled.	

## 19.6 PERFORMANCE MONITORING EVENTS FOR INTEL® XEON® PROCESSOR 5200, 5400 SERIES AND INTEL® CORE™ 2 EXTREME PROCESSORS QX 9000 SERIES

Processors based on the Enhanced Intel Core microarchitecture support the architectural and non-architectural performance-monitoring events listed in Table 19-1 and Table 19-13. In addition, they also support the following non-architectural performance-monitoring events listed in Table 19-11. Fixed counters support the architecture events defined in Table 19-12.

**Table 19-11. Non-Architectural Performance Events for Processors Based on Enhanced Intel Core Microarchitecture**

Event Num.	Umask Value	Event Mask Mnemonic	Description	Comment
COH	08H	INST_RETIRED.VM_H OST	Instruction retired while in VMX root operations.	
D2H	10H	RAT_STAALS.OTHER _SERIALIZATION_ST ALLS	This events counts the number of stalls due to other RAT resource serialization not counted by Umask value 0FH.	

## 19.7 PERFORMANCE MONITORING EVENTS FOR INTEL® XEON® PROCESSOR 3000, 3200, 5100, 5300 SERIES AND INTEL® CORE™ 2 DUO PROCESSORS

Processors based on the Intel Core microarchitecture support architectural and non-architectural performance-monitoring events.

Fixed-function performance counters are introduced first on processors based on Intel Core microarchitecture. Table 19-12 lists pre-defined performance events that can be counted using fixed-function performance counters.



**Table 19-12. Fixed-Function Performance Counter and Pre-defined Performance Events**

Fixed-Function Performance Counter	Address	Event Mask Mnemonic	Description
MSR_PERF_FIXED_CTR0/IA32_PERF_FIXED_CTR0	309H	Inst_Retired.Any	This event counts the number of instructions that retire execution. For instructions that consist of multiple micro-ops, this event counts the retirement of the last micro-op of the instruction. The counter continue counting during hardware interrupts, traps, and inside interrupt handlers.
MSR_PERF_FIXED_CTR1/IA32_PERF_FIXED_CTR1	30AH	CPU_CLK_UNHALTED.CORE	<p>This event counts the number of core cycles while the core is not in a halt state. The core enters the halt state when it is running the HLT instruction. This event is a component in many key event ratios.</p> <p>The core frequency may change from time to time due to transitions associated with Enhanced Intel SpeedStep Technology or TM2. For this reason this event may have a changing ratio with regards to time.</p> <p>When the core frequency is constant, this event can approximate elapsed time while the core was not in halt state.</p>
MSR_PERF_FIXED_CTR2/IA32_PERF_FIXED_CTR2	30BH	CPU_CLK_UNHALTED.REF	<p>This event counts the number of reference cycles when the core is not in a halt state and not in a TM stop-clock state. The core enters the halt state when it is running the HLT instruction or the MWAIT instruction.</p> <p>This event is not affected by core frequency changes (e.g., P states) but counts at the same frequency as the time stamp counter. This event can approximate elapsed time while the core was not in halt state and not in a TM stop-clock state.</p> <p>This event has a constant ratio with the CPU_CLK_UNHALTED.BUS event.</p>

Table 19-13 lists general-purpose non-architectural performance-monitoring events supported in processors based on Intel Core microarchitecture. For convenience,

Table 19-13 also includes architectural events and describes minor model-specific behavior where applicable. Software must use a general-purpose performance counter to count events listed in Table 19-13.

**Table 19-13. Non-Architectural Performance Events in Processors Based on Intel Core Microarchitecture**

Event Num	Umask Value	Event Name	Definition	Description and Comment
03H	02H	LOAD_BLOCK.STA	Loads blocked by a preceding store with unknown address	<p>This event indicates that loads are blocked by preceding stores. A load is blocked when there is a preceding store to an address that is not yet calculated. The number of events is greater or equal to the number of load operations that were blocked.</p> <p>If the load and the store are always to different addresses, check why the memory disambiguation mechanism is not working. To avoid such blocks, increase the distance between the store and the following load so that the store address is known at the time the load is dispatched.</p>
03H	04H	LOAD_BLOCK.STD	Loads blocked by a preceding store with unknown data	<p>This event indicates that loads are blocked by preceding stores. A load is blocked when there is a preceding store to the same address and the stored data value is not yet known. The number of events is greater or equal to the number of load operations that were blocked.</p> <p>To avoid such blocks, increase the distance between the store and the dependant load, so that the store data is known at the time the load is dispatched.</p>
03H	08H	LOAD_BLOCK.OVERLAP_STORE	Loads that partially overlap an earlier store, or 4-Kbyte aliased with a previous store	<p>This event indicates that loads are blocked due to a variety of reasons. Some of the triggers for this event are when a load is blocked by a preceding store, in one of the following:</p> <ul style="list-style-type: none"> <li>▪ Some of the loaded byte locations are written by the preceding store and some are not.</li> <li>▪ The load is from bytes written by the preceding store, the store is aligned to its size and either:</li> </ul>

**Table 19-13. Non-Architectural Performance Events  
in Processors Based on Intel Core Microarchitecture (Contd.)**

Event Num	Umask Value	Event Name	Definition	Description and Comment
				<ul style="list-style-type: none"> <li>▪ The load's data size is one or two bytes and it is not aligned to the store.</li> <li>▪ The load's data size is of four or eight bytes and the load is misaligned.</li> </ul>
				<ul style="list-style-type: none"> <li>▪ The load is from bytes written by the preceding store, the store is misaligned and the load is not aligned on the beginning of the store.</li> <li>▪ The load is split over an eight byte boundary (excluding 16-byte loads).</li> <li>▪ The load and store have the same offset relative to the beginning of different 4-KByte pages. This case is also called 4-KByte aliasing.</li> <li>▪ In all these cases the load is blocked until after the blocking store retires and the stored data is committed to the cache hierarchy.</li> </ul>
03H	10H	LOAD_BLOCK. UNTIL_RETIRE	Loads blocked until retirement	<p>This event indicates that load operations were blocked until retirement. The number of events is greater or equal to the number of load operations that were blocked.</p> <p>This includes mainly uncacheable loads and split loads (loads that cross the cache line boundary) but may include other cases where loads are blocked until retirement.</p>

**Table 19-13. Non-Architectural Performance Events  
in Processors Based on Intel Core Microarchitecture (Contd.)**

Event Num	Umask Value	Event Name	Definition	Description and Comment
03H	20H	LOAD_BLOCK.L1D	Loads blocked by the L1 data cache	<p>This event indicates that loads are blocked due to one or more reasons. Some triggers for this event are:</p> <ul style="list-style-type: none"> <li>▪ The number of L1 data cache misses exceeds the maximum number of outstanding misses supported by the processor. This includes misses generated as result of demand fetches, software prefetches or hardware prefetches.</li> <li>▪ Cache line split loads.</li> <li>▪ Partial reads, such as reads to un-cacheable memory, I/O instructions and more.</li> <li>▪ A locked load operation is in progress. The number of events is greater or equal to the number of load operations that were blocked.</li> </ul>
04H	01H	SB_DRAIN_CYCLES	Cycles while stores are blocked due to store buffer drain	<p>This event counts every cycle during which the store buffer is draining. This includes:</p> <ul style="list-style-type: none"> <li>▪ Serializing operations such as CPUID</li> <li>▪ Synchronizing operations such as XCHG</li> <li>▪ Interrupt acknowledgment</li> <li>▪ Other conditions, such as cache flushing</li> </ul>
04H	02H	STORE_BLOCK.ORDER	Cycles while store is waiting for a preceding store to be globally observed	<p>This event counts the total duration, in number of cycles, which stores are waiting for a preceding stored cache line to be observed by other cores. This situation happens as a result of the strong store ordering behavior, as defined in "Memory Ordering," Chapter 8, <i>Intel® 64 and IA-32 Architectures Software Developer's Manual, Volume 3A</i>.</p> <p>The stall may occur and be noticeable if there are many cases when a store either misses the L1 data cache or hits a cache line in the Shared state. If the store requires a bus transaction to read the cache line then the stall ends when snoop response for the bus transaction arrives.</p>

**Table 19-13. Non-Architectural Performance Events  
in Processors Based on Intel Core Microarchitecture (Contd.)**

Event Num	Umask Value	Event Name	Definition	Description and Comment
04H	08H	STORE_BLOCK.SNOOP	A store is blocked due to a conflict with an external or internal snoop.	This event counts the number of cycles the store port was used for snooping the L1 data cache and a store was stalled by the snoop. The store is typically resubmitted one cycle later.
06H	00H	SEGMENT_REG_LOADS	Number of segment register loads	This event counts the number of segment register load operations. Instructions that load new values into segment registers cause a penalty.
				<p>This event indicates performance issues in 16-bit code. If this event occurs frequently, it may be useful to calculate the number of instructions retired per segment register load. If the resulting calculation is low (on average a small number of instructions are executed between segment register loads), then the code's segment register usage should be optimized.</p> <p>As a result of branch misprediction, this event is speculative and may include segment register loads that do not actually occur. However, most segment register loads are internally serialized and such speculative effects are minimized.</p>
07H	00H	SSE_PRE_EXEC.NTA	Streaming SIMD Extensions (SSE) Prefetch NTA instructions executed	This event counts the number of times the SSE instruction prefetchNTA is executed. This instruction prefetches the data to the L1 data cache.
07H	01H	SSE_PRE_EXEC.L1	Streaming SIMD Extensions (SSE) PrefetchT0 instructions executed	This event counts the number of times the SSE instruction prefetchT0 is executed. This instruction prefetches the data to the L1 data cache and L2 cache.

**Table 19-13. Non-Architectural Performance Events  
in Processors Based on Intel Core Microarchitecture (Contd.)**

Event Num	Umask Value	Event Name	Definition	Description and Comment
07H	02H	SSE_PRE_EXEC.L2	Streaming SIMD Extensions (SSE) PrefetchT1 and PrefetchT2 instructions executed	This event counts the number of times the SSE instructions prefetchT1 and prefetchT2 are executed. These instructions prefetch the data to the L2 cache.
07H	03H	SSE_PRE_EXEC.STORES	Streaming SIMD Extensions (SSE) Weakly-ordered store instructions executed	This event counts the number of times SSE non-temporal store instructions are executed.
08H	01H	DTLB_MISSES.ANY	Memory accesses that missed the DTLB	This event counts the number of Data Table Lookaside Buffer (DTLB) misses. The count includes misses detected as a result of speculative accesses.  Typically a high count for this event indicates that the code accesses a large number of data pages.
08H	02H	DTLB_MISSES.MISS_LD	DTLB misses due to load operations	This event counts the number of Data Table Lookaside Buffer (DTLB) misses due to load operations.  This count includes misses detected as a result of speculative accesses.
08H	04H	DTLB_MISSES.LO_MISS_LD	LO DTLB misses due to load operations	This event counts the number of level 0 Data Table Lookaside Buffer (DTLB0) misses due to load operations.  This count includes misses detected as a result of speculative accesses. Loads that miss that DTLB0 and hit the DTLB1 can incur two-cycle penalty.

**Table 19-13. Non-Architectural Performance Events  
in Processors Based on Intel Core Microarchitecture (Contd.)**

Event Num	Umask Value	Event Name	Definition	Description and Comment
08H	08H	DTLB_MISSES. MISS_ST	TLB misses due to store operations	<p>This event counts the number of Data Table Lookaside Buffer (DTLB) misses due to store operations.</p> <p>This count includes misses detected as a result of speculative accesses. Address translation for store operations is performed in the DTLB1.</p>
09H	01H	MEMORY_ DISAMBIGUATION. RESET	Memory disambiguation reset cycles	<p>This event counts the number of cycles during which memory disambiguation misprediction occurs. As a result the execution pipeline is cleaned and execution of the mispredicted load instruction and all succeeding instructions restarts.</p> <p>This event occurs when the data address accessed by a load instruction, collides infrequently with preceding stores, but usually there is no collision. It happens rarely, and may have a penalty of about 20 cycles.</p>
09H	02H	MEMORY_DISAMBI GUATION.SUCCESS	Number of loads successfully disambiguated.	This event counts the number of load operations that were successfully disambiguated. Loads are preceded by a store with an unknown address, but they are not blocked.
0CH	01H	PAGE_WALKS .COUNT	Number of page-walks executed	<p>This event counts the number of page-walks executed due to either a DTLB or ITLB miss.</p> <p>The page walk duration, PAGE_WALKS.CYCLES, divided by number of page walks is the average duration of a page walk. The average can hint whether most of the page-walks are satisfied by the caches or cause an L2 cache miss.</p>

**Table 19-13. Non-Architectural Performance Events  
in Processors Based on Intel Core Microarchitecture (Contd.)**

Event Num	Umask Value	Event Name	Definition	Description and Comment
0CH	02H	PAGE_WALKS. CYCLES	Duration of page-walks in core cycles	This event counts the duration of page-walks in core cycles. The paging mode in use typically affects the duration of page walks.  Page walk duration divided by number of page walks is the average duration of page-walks. The average can hint at whether most of the page-walks are satisfied by the caches or cause an L2 cache miss.
10H	00H	FP_COMP_OPS _EXE	Floating point computational micro-ops executed	This event counts the number of floating point computational micro-ops executed. Use IA32_PMC0 only.
11H	00H	FP_ASSIST	Floating point assists	This event counts the number of floating point operations executed that required micro-code assist intervention. Assists are required in the following cases: <ul style="list-style-type: none"> <li>▪ Streaming SIMD Extensions (SSE) instructions:</li> <li>▪ Denormal input when the DAZ (Denormals Are Zeros) flag is off</li> <li>▪ Underflow result when the FTZ (Flush To Zero) flag is off</li> <li>▪ X87 instructions:</li> <li>▪ NaN or denormal are loaded to a register or used as input from memory</li> <li>▪ Division by 0</li> <li>▪ Underflow output</li> </ul> Use IA32_PMC1 only.
12H	00H	MUL	Multiply operations executed	This event counts the number of multiply operations executed. This includes integer as well as floating point multiply operations.  Use IA32_PMC1 only.
13H	00H	DIV	Divide operations executed	This event counts the number of divide operations executed. This includes integer divides, floating point divides and square-root operations executed.  Use IA32_PMC1 only.



**Table 19-13. Non-Architectural Performance Events  
in Processors Based on Intel Core Microarchitecture (Contd.)**

Event Num	Umask Value	Event Name	Definition	Description and Comment
14H	00H	CYCLES_DIV_BUSY	Cycles the divider busy	This event counts the number of cycles the divider is busy executing divide or square root operations. The divide can be integer, X87 or Streaming SIMD Extensions (SSE). The square root operation can be either X87 or SSE. Use IA32_PMC0 only.
18H	00H	IDLE_DURING_DIV	Cycles the divider is busy and all other execution units are idle.	This event counts the number of cycles the divider is busy (with a divide or a square root operation) and no other execution unit or load operation is in progress. Load operations are assumed to hit the L1 data cache. This event considers only micro-ops dispatched after the divider started operating. Use IA32_PMC0 only.
19H	00H	DELAYED_BYPASS.FP	Delayed bypass to FP operation	This event counts the number of times floating point operations use data immediately after the data was generated by a non-floating point execution unit. Such cases result in one penalty cycle due to data bypass between the units. Use IA32_PMC1 only.
19H	01H	DELAYED_BYPASS.SIMD	Delayed bypass to SIMD operation	This event counts the number of times SIMD operations use data immediately after the data was generated by a non-SIMD execution unit. Such cases result in one penalty cycle due to data bypass between the units. Use IA32_PMC1 only.

**Table 19-13. Non-Architectural Performance Events  
in Processors Based on Intel Core Microarchitecture (Contd.)**

Event Num	Umask Value	Event Name	Definition	Description and Comment
19H	02H	DELAYED_BYPASS.LOAD	Delayed bypass to load operation	This event counts the number of delayed bypass penalty cycles that a load operation incurred.  When load operations use data immediately after the data was generated by an integer execution unit, they may (pending on certain dynamic internal conditions) incur one penalty cycle due to delayed data bypass between the units. Use IA32_PMC1 only.
21H	See Table 18-2	L2_ADS.(Core)	Cycles L2 address bus is in use	This event counts the number of cycles the L2 address bus is being used for accesses to the L2 cache or bus queue. It can count occurrences for this core or both cores.
23H	See Table 18-2	L2_DBUS_BUSY_RD.(Core)	Cycles the L2 transfers data to the core	This event counts the number of cycles during which the L2 data bus is busy transferring data from the L2 cache to the core. It counts for all L1 cache misses (data and instruction) that hit the L2 cache.  This event can count occurrences for this core or both cores.
24H	Combined mask from Table 18-2 and Table 18-4	L2_LINES_IN.(Core, Prefetch)	L2 cache misses	This event counts the number of cache lines allocated in the L2 cache. Cache lines are allocated in the L2 cache as a result of requests from the L1 data and instruction caches and the L2 hardware prefetchers to cache lines that are missing in the L2 cache.  This event can count occurrences for this core or both cores. It can also count demand requests and L2 hardware prefetch requests together or separately.
25H	See Table 18-2	L2_M_LINES_IN.(Core)	L2 cache line modifications	This event counts whenever a modified cache line is written back from the L1 data cache to the L2 cache.  This event can count occurrences for this core or both cores.

**Table 19-13. Non-Architectural Performance Events  
in Processors Based on Intel Core Microarchitecture (Contd.)**

Event Num	Umask Value	Event Name	Definition	Description and Comment
26H	See Table 18-2 and Table 18-4	L2_LINES_OUT. (Core, Prefetch)	L2 cache lines evicted	This event counts the number of L2 cache lines evicted.  This event can count occurrences for this core or both cores. It can also count evictions due to demand requests and L2 hardware prefetch requests together or separately.
27H	See Table 18-2 and Table 18-4	L2_M_LINES_OUT. (Core, Prefetch)	Modified lines evicted from the L2 cache	This event counts the number of L2 modified cache lines evicted. These lines are written back to memory unless they also exist in a modified-state in one of the L1 data caches.  This event can count occurrences for this core or both cores. It can also count evictions due to demand requests and L2 hardware prefetch requests together or separately.
28H	Combined mask from Table 18-2 and Table 18-5	L2_IFETCH.(Core, Cache Line State)	L2 cacheable instruction fetch requests	This event counts the number of instruction cache line requests from the IFU. It does not include fetch requests from uncacheable memory. It does not include ITLB miss accesses.  This event can count occurrences for this core or both cores. It can also count accesses to cache lines at different MESI states.
29H	Combined mask from Table 18-2, Table 18-4, and Table 18-5	L2_LD.(Core, Prefetch, Cache Line State)	L2 cache reads	This event counts L2 cache read requests coming from the L1 data cache and L2 prefetchers.  The event can count occurrences: <ul style="list-style-type: none"> <li>▪ for this core or both cores</li> <li>▪ due to demand requests and L2 hardware prefetch requests together or separately</li> <li>▪ of accesses to cache lines at different MESI states</li> </ul>

**Table 19-13. Non-Architectural Performance Events  
in Processors Based on Intel Core Microarchitecture (Contd.)**

Event Num	Umask Value	Event Name	Definition	Description and Comment
2AH	See Table 18-2 and Table 18-5	L2_ST.(Core, Cache Line State)	L2 store requests	This event counts all store operations that miss the L1 data cache and request the data from the L2 cache.  The event can count occurrences for this core or both cores. It can also count accesses to cache lines at different MESI states.
2BH	See Table 18-2 and Table 18-5	L2_LOCK.(Core, Cache Line State)	L2 locked accesses	This event counts all locked accesses to cache lines that miss the L1 data cache.  The event can count occurrences for this core or both cores. It can also count accesses to cache lines at different MESI states.
2EH	See Table 18-2, Table 18-4, and Table 18-5	L2_RQSTS.(Core, Prefetch, Cache Line State)	L2 cache requests	This event counts all completed L2 cache requests. This includes L1 data cache reads, writes, and locked accesses, L1 data prefetch requests, instruction fetches, and all L2 hardware prefetch requests.  This event can count occurrences: <ul style="list-style-type: none"> <li>▪ for this core or both cores.</li> <li>▪ due to demand requests and L2 hardware prefetch requests together, or separately</li> <li>▪ of accesses to cache lines at different MESI states</li> </ul>
2EH	41H	L2_RQSTS.SELF.DEMAND.I_STATE	L2 cache demand requests from this core that missed the L2	This event counts all completed L2 cache demand requests from this core that miss the L2 cache. This includes L1 data cache reads, writes, and locked accesses, L1 data prefetch requests, and instruction fetches.  This is an architectural performance event.
2EH	4FH	L2_RQSTS.SELF.DEMAND.MESI	L2 cache demand requests from this core	This event counts all completed L2 cache demand requests from this core. This includes L1 data cache reads, writes, and locked accesses, L1 data prefetch requests, and instruction fetches.  This is an architectural performance event.

**Table 19-13. Non-Architectural Performance Events  
in Processors Based on Intel Core Microarchitecture (Contd.)**

Event Num	Umask Value	Event Name	Definition	Description and Comment
30H	See Table 18-2, Table 18-4, and Table 18-5	L2_REJECT_BUSQ.(Core, Prefetch, Cache Line State)	Rejected L2 cache requests	<p>This event indicates that a pending L2 cache request that requires a bus transaction is delayed from moving to the bus queue. Some of the reasons for this event are:</p> <ul style="list-style-type: none"> <li>▪ The bus queue is full.</li> <li>▪ The bus queue already holds an entry for a cache line in the same set.</li> </ul> <p>The number of events is greater or equal to the number of requests that were rejected.</p> <ul style="list-style-type: none"> <li>▪ for this core or both cores.</li> <li>▪ due to demand requests and L2 hardware prefetch requests together, or separately.</li> <li>▪ of accesses to cache lines at different MESI states.</li> </ul>
32H	See Table 18-2	L2_NO_REQ.(Core)	Cycles no L2 cache requests are pending	<p>This event counts the number of cycles that no L2 cache requests were pending from a core. When using the BOTH_CORE modifier, the event counts only if none of the cores have a pending request. The event counts also when one core is halted and the other is not halted.</p> <p>The event can count occurrences for this core or both cores.</p>
3AH	00H	EIST_TRANS	Number of Enhanced Intel SpeedStep Technology (EIST) transitions	<p>This event counts the number of transitions that include a frequency change, either with or without voltage change. This includes Enhanced Intel SpeedStep Technology (EIST) and TM2 transitions.</p> <p>The event is incremented only while the counting core is in C0 state. Since transitions to higher-numbered CxE states and TM2 transitions include a frequency change or voltage transition, the event is incremented accordingly.</p>

**Table 19-13. Non-Architectural Performance Events  
in Processors Based on Intel Core Microarchitecture (Contd.)**

Event Num	Umask Value	Event Name	Definition	Description and Comment
3BH	COH	THERMAL_TRIP	Number of thermal trips	<p>This event counts the number of thermal trips. A thermal trip occurs whenever the processor temperature exceeds the thermal trip threshold temperature.</p> <p>Following a thermal trip, the processor automatically reduces frequency and voltage. The processor checks the temperature every millisecond and returns to normal when the temperature falls below the thermal trip threshold temperature.</p>
3CH	00H	CPU_CLK_UNHALTED.CORE_P	Core cycles when core is not halted	<p>This event counts the number of core cycles while the core is not in a halt state. The core enters the halt state when it is running the HLT instruction. This event is a component in many key event ratios.</p> <p>The core frequency may change due to transitions associated with Enhanced Intel SpeedStep Technology or TM2. For this reason, this event may have a changing ratio in regard to time.</p> <p>When the core frequency is constant, this event can give approximate elapsed time while the core not in halt state.</p> <p>This is an architectural performance event.</p>
3CH	01H	CPU_CLK_UNHALTED.BUS	Bus cycles when core is not halted	<p>This event counts the number of bus cycles while the core is not in the halt state. This event can give a measurement of the elapsed time while the core was not in the halt state. The core enters the halt state when it is running the HLT instruction.</p> <p>The event also has a constant ratio with CPU_CLK_UNHALTED.REF event, which is the maximum bus to processor frequency ratio.</p> <p>Non-halted bus cycles are a component in many key event ratios.</p>

**Table 19-13. Non-Architectural Performance Events  
in Processors Based on Intel Core Microarchitecture (Contd.)**

Event Num	Umask Value	Event Name	Definition	Description and Comment
3CH	02H	CPU_CLK_UNHALTED.NO_OTHER	Bus cycles when core is active and the other is halted	<p>This event counts the number of bus cycles during which the core remains non-halted and the other core on the processor is halted.</p> <p>This event can be used to determine the amount of parallelism exploited by an application or a system. Divide this event count by the bus frequency to determine the amount of time that only one core was in use.</p>
40H	See Table 18-5	L1D_CACHE_LD. (Cache Line State)	L1 cacheable data reads	This event counts the number of data reads from cacheable memory. Locked reads are not counted.
41H	See Table 18-5	L1D_CACHE_ST. (Cache Line State)	L1 cacheable data writes	This event counts the number of data writes to cacheable memory. Locked writes are not counted.
42H	See Table 18-5	L1D_CACHE_LOCK. (Cache Line State)	L1 data cacheable locked reads	This event counts the number of locked data reads from cacheable memory.
42H	10H	L1D_CACHE_LOCK_DURATION	Duration of L1 data cacheable locked operation	<p>This event counts the number of cycles during which any cache line is locked by any locking instruction.</p> <p>Locking happens at retirement and therefore the event does not occur for instructions that are speculatively executed. Locking duration is shorter than locked instruction execution duration.</p>
43H	01H	L1D_ALL_REF	All references to the L1 data cache	<p>This event counts all references to the L1 data cache, including all loads and stores with any memory types.</p> <p>The event counts memory accesses only when they are actually performed. For example, a load blocked by unknown store address and later performed is only counted once.</p> <p>The event includes non-cacheable accesses, such as I/O accesses.</p>

**Table 19-13. Non-Architectural Performance Events  
in Processors Based on Intel Core Microarchitecture (Contd.)**

Event Num	Umask Value	Event Name	Definition	Description and Comment
43H	02H	L1D_ALL_CACHE_REF	L1 Data cacheable reads and writes	This event counts the number of data reads and writes from cacheable memory, including locked operations.  This event is a sum of: <ul style="list-style-type: none"> <li>▪ L1D_CACHE_LD.MESI</li> <li>▪ L1D_CACHE_ST.MESI</li> <li>▪ L1D_CACHE_LOCK.MESI</li> </ul>
45H	0FH	L1D_REPL	Cache lines allocated in the L1 data cache	This event counts the number of lines brought into the L1 data cache.
46H	00H	L1D_M_REPL	Modified cache lines allocated in the L1 data cache	This event counts the number of modified lines brought into the L1 data cache.
47H	00H	L1D_M_EVICT	Modified cache lines evicted from the L1 data cache	This event counts the number of modified lines evicted from the L1 data cache, whether due to replacement or by snoop HITM intervention.
48H	00H	L1D_PEND_MISS	Total number of outstanding L1 data cache misses at any cycle	This event counts the number of outstanding L1 data cache misses at any cycle. An L1 data cache miss is outstanding from the cycle on which the miss is determined until the first chunk of data is available. This event counts: <ul style="list-style-type: none"> <li>▪ all cacheable demand requests</li> <li>▪ L1 data cache hardware prefetch requests</li> <li>▪ requests to write through memory</li> <li>▪ requests to write combine memory</li> </ul> Uncacheable requests are not counted. The count of this event divided by the number of L1 data cache misses, L1D_REPL, is the average duration in core cycles of an L1 data cache miss.
49H	01H	L1D_SPLIT.LOADS	Cache line split loads from the L1 data cache	This event counts the number of load operations that span two cache lines. Such load operations are also called split loads. Split load operations are executed at retirement.



**Table 19-13. Non-Architectural Performance Events  
in Processors Based on Intel Core Microarchitecture (Contd.)**

Event Num	Umask Value	Event Name	Definition	Description and Comment
49H	02H	L1D_SPLIT.STORES	Cache line split stores to the L1 data cache	This event counts the number of store operations that span two cache lines.
4BH	00H	SSE_PRE_MISS.NTA	Streaming SIMD Extensions (SSE) Prefetch NTA instructions missing all cache levels	This event counts the number of times the SSE instructions prefetchNTA were executed and missed all cache levels. Due to speculation an executed instruction might not retire. This instruction prefetches the data to the L1 data cache.
4BH	01H	SSE_PRE_MISS.L1	Streaming SIMD Extensions (SSE) PrefetchT0 instructions missing all cache levels	This event counts the number of times the SSE instructions prefetchT0 were executed and missed all cache levels. Due to speculation executed instruction might not retire. The prefetchT0 instruction prefetches data to the L2 cache and L1 data cache.
4BH	02H	SSE_PRE_MISS.L2	Streaming SIMD Extensions (SSE) PrefetchT1 and PrefetchT2 instructions missing all cache levels	This event counts the number of times the SSE instructions prefetchT1 and prefetchT2 were executed and missed all cache levels. Due to speculation, an executed instruction might not retire. The prefetchT1 and PrefetchNT2 instructions prefetch data to the L2 cache.
4CH	00H	LOAD_HIT_PRE	Load operations conflicting with a software prefetch to the same address	This event counts load operations sent to the L1 data cache while a previous Streaming SIMD Extensions (SSE) prefetch instruction to the same cache line has started prefetching but has not yet finished.
4EH	10H	L1D_PREFETCH.REQUESTS	L1 data cache prefetch requests	This event counts the number of times the L1 data cache requested to prefetch a data cache line. Requests can be rejected when the L2 cache is busy and resubmitted later or lost. All requests are counted, including those that are rejected.

**Table 19-13. Non-Architectural Performance Events  
in Processors Based on Intel Core Microarchitecture (Contd.)**

<b>Event Num</b>	<b>Umask Value</b>	<b>Event Name</b>	<b>Definition</b>	<b>Description and Comment</b>
60H	See Table 18-2 and Table 18-3	BUS_REQUEST_OUTSTANDING. (Core and Bus Agents)	Outstanding cacheable data read bus requests duration	<p>This event counts the number of pending full cache line read transactions on the bus occurring in each cycle. A read transaction is pending from the cycle it is sent on the bus until the full cache line is received by the processor.</p> <p>The event counts only full-line cacheable read requests from either the L1 data cache or the L2 prefetchers. It does not count Read for Ownership transactions, instruction byte fetch transactions, or any other bus transaction.</p>
61H	See Table 18-3.	BUS_BNR_DRV. (Bus Agents)	Number of Bus Not Ready signals asserted	<p>This event counts the number of Bus Not Ready (BNR) signals that the processor asserts on the bus to suspend additional bus requests by other bus agents.</p> <p>A bus agent asserts the BNR signal when the number of data and snoop transactions is close to the maximum that the bus can handle. To obtain the number of bus cycles during which the BNR signal is asserted, multiply the event count by two.</p> <p>While this signal is asserted, new transactions cannot be submitted on the bus. As a result, transaction latency may have higher impact on program performance.</p>

**Table 19-13. Non-Architectural Performance Events  
in Processors Based on Intel Core Microarchitecture (Contd.)**

Event Num	Umask Value	Event Name	Definition	Description and Comment
62H	See Table 18-3	BUS_DRDY_CLOCKS.(Bus Agents)	Bus cycles when data is sent on the bus	This event counts the number of bus cycles during which the DRDY (Data Ready) signal is asserted on the bus. The DRDY signal is asserted when data is sent on the bus. With the 'THIS_AGENT' mask this event counts the number of bus cycles during which this agent (the processor) writes data on the bus back to memory or to other bus agents. This includes all explicit and implicit data writebacks, as well as partial writes. With the 'ALL_AGENTS' mask, this event counts the number of bus cycles during which any bus agent sends data on the bus. This includes all data reads and writes on the bus.
63H	See Table 18-2 and Table 18-3	BUS_LOCK_CLOCKS.(Core and Bus Agents)	Bus cycles when a LOCK signal asserted	This event counts the number of bus cycles, during which the LOCK signal is asserted on the bus. A LOCK signal is asserted when there is a locked memory access, due to: <ul style="list-style-type: none"> <li>▪ uncacheable memory</li> <li>▪ locked operation that spans two cache lines</li> <li>▪ page-walk from an uncacheable page table</li> </ul> Bus locks have a very high performance penalty and it is highly recommended to avoid such accesses.
64H	See Table 18-2	BUS_DATA_RCV.(Core)	Bus cycles while processor receives data	This event counts the number of bus cycles during which the processor is busy receiving data.
65H	See Table 18-2 and Table 18-3	BUS_TRANS_BRD.(Core and Bus Agents)	Burst read bus transactions	This event counts the number of burst read transactions including: <ul style="list-style-type: none"> <li>▪ L1 data cache read misses (and L1 data cache hardware prefetches)</li> <li>▪ L2 hardware prefetches by the DPL and L2 streamer</li> <li>▪ IFU read misses of cacheable lines.</li> </ul> It does not include RFO transactions.

**Table 19-13. Non-Architectural Performance Events  
in Processors Based on Intel Core Microarchitecture (Contd.)**

<b>Event Num</b>	<b>Umask Value</b>	<b>Event Name</b>	<b>Definition</b>	<b>Description and Comment</b>
66H	See Table 18-2 and Table 18-3.	BUS_TRANS_RFO.(Core and Bus Agents)	RFO bus transactions	This event counts the number of Read For Ownership (RFO) bus transactions, due to store operations that miss the L1 data cache and the L2 cache. It also counts RFO bus transactions due to locked operations.
67H	See Table 18-2 and Table 18-3.	BUS_TRANS_WB.(Core and Bus Agents)	Explicit writeback bus transactions	This event counts all explicit writeback bus transactions due to dirty line evictions. It does not count implicit writebacks due to invalidation by a snoop request.
68H	See Table 18-2 and Table 18-3	BUS_TRANS_IFETCH.(Core and Bus Agents)	Instruction-fetch bus transactions	This event counts all instruction fetch full cache line bus transactions.
69H	See Table 18-2 and Table 18-3	BUS_TRANS_INVALID.(Core and Bus Agents)	Invalidate bus transactions	This event counts all invalidate transactions. Invalidate transactions are generated when: <ul style="list-style-type: none"> <li>▪ A store operation hits a shared line in the L2 cache.</li> <li>▪ A full cache line write misses the L2 cache or hits a shared line in the L2 cache.</li> </ul>
6AH	See Table 18-2 and Table 18-3	BUS_TRANS_PWR.(Core and Bus Agents)	Partial write bus transaction	This event counts partial write bus transactions.
6BH	See Table 18-2 and Table 18-3	BUS_TRANS_P.(Core and Bus Agents)	Partial bus transactions	This event counts all (read and write) partial bus transactions.

**Table 19-13. Non-Architectural Performance Events  
in Processors Based on Intel Core Microarchitecture (Contd.)**

Event Num	Umask Value	Event Name	Definition	Description and Comment
6CH	See Table 18-2 and Table 18-3	BUS_TRANS_IO.(Core and Bus Agents)	IO bus transactions	This event counts the number of completed I/O bus transactions as a result of IN and OUT instructions. The count does not include memory mapped IO.
6DH	See Table 18-2 and Table 18-3	BUS_TRANS_DEF.(Core and Bus Agents)	Deferred bus transactions	This event counts the number of deferred transactions.
6EH	See Table 18-2 and Table 18-3	BUS_TRANS_BURST.(Core and Bus Agents)	Burst (full cache-line) bus transactions	This event counts burst (full cache line) transactions including: <ul style="list-style-type: none"> <li>▪ Burst reads</li> <li>▪ RFOs</li> <li>▪ Explicit writebacks</li> <li>▪ Write combine lines</li> </ul>
6FH	See Table 18-2 and Table 18-3	BUS_TRANS_MEM.(Core and Bus Agents)	Memory bus transactions	This event counts all memory bus transactions including: <ul style="list-style-type: none"> <li>▪ Burst transactions</li> <li>▪ Partial reads and writes - invalidate transactions</li> </ul> <p>The BUS_TRANS_MEM count is the sum of BUS_TRANS_BURST, BUS_TRANS_P and BUS_TRANS_IVAL.</p>
70H	See Table 18-2 and Table 18-3	BUS_TRANS_ANY.(Core and Bus Agents)	All bus transactions	This event counts all bus transactions. This includes: <ul style="list-style-type: none"> <li>▪ Memory transactions</li> <li>▪ IO transactions (non memory-mapped)</li> <li>▪ Deferred transaction completion</li> <li>▪ Other less frequent transactions, such as interrupts</li> </ul>

**Table 19-13. Non-Architectural Performance Events in Processors Based on Intel Core Microarchitecture (Contd.)**

Event Num	Umask Value	Event Name	Definition	Description and Comment
77H	See Table 18-2 and Table 18-6	EXT_SNOOP. (Bus Agents, Snoop Response)	External snoops	This event counts the snoop responses to bus transactions. Responses can be counted separately by type and by bus agent.  With the 'THIS_AGENT' mask, the event counts snoop responses from this processor to bus transactions sent by this processor. With the 'ALL_AGENTS' mask the event counts all snoop responses seen on the bus.
78H	See Table 18-2 and Table 18-7	CMP_SNOOP.(Core, Snoop Type)	L1 data cache snooped by other core	This event counts the number of times the L1 data cache is snooped for a cache line that is needed by the other core in the same processor. The cache line is either missing in the L1 instruction or data caches of the other core, or is available for reading only and the other core wishes to write the cache line.
				The snoop operation may change the cache line state. If the other core issued a read request that hit this core in E state, typically the state changes to S state in this core. If the other core issued a read for ownership request (due a write miss or hit to S state) that hits this core's cache line in E or S state, this typically results in invalidation of the cache line in this core. If the snoop hits a line in M state, the state is changed at a later opportunity.  These snoops are performed through the L1 data cache store port. Therefore, frequent snoops may conflict with extensive stores to the L1 data cache, which may increase store latency and impact performance.
7AH	See Table 18-3	BUS_HIT_DRV. (Bus Agents)	HIT signal asserted	This event counts the number of bus cycles during which the processor drives the HIT# pin to signal HIT snoop response.

**Table 19-13. Non-Architectural Performance Events  
in Processors Based on Intel Core Microarchitecture (Contd.)**

Event Num	Umask Value	Event Name	Definition	Description and Comment
7BH	See Table 18-3	BUS_HITM_DRV. (Bus Agents)	HITM signal asserted	This event counts the number of bus cycles during which the processor drives the HITM# pin to signal HITM snoop response.
7DH	See Table 18-2	BUSQ_EMPTY. (Core)	Bus queue empty	This event counts the number of cycles during which the core did not have any pending transactions in the bus queue. It also counts when the core is halted and the other core is not halted.  This event can count occurrences for this core or both cores.
7EH	See Table 18-2 and Table 18-3	SNOOP_STALL_DRV. (Core and Bus Agents)	Bus stalled for snoops	This event counts the number of times that the bus snoop stall signal is asserted. To obtain the number of bus cycles during which snoops on the bus are prohibited, multiply the event count by two.  During the snoop stall cycles, no new bus transactions requiring a snoop response can be initiated on the bus. A bus agent asserts a snoop stall signal if it cannot respond to a snoop request within three bus cycles.
7FH	See Table 18-2	BUS_IO_WAIT. (Core)	IO requests waiting in the bus queue	This event counts the number of core cycles during which IO requests wait in the bus queue. With the SELF modifier this event counts IO requests per core.  With the BOTH_CORE modifier, this event increments by one for any cycle for which there is a request from either core.
80H	00H	L11_READS	Instruction fetches	This event counts all instruction fetches, including uncacheable fetches that bypass the Instruction Fetch Unit (IFU).
81H	00H	L11_MISSES	Instruction Fetch Unit misses	This event counts all instruction fetches that miss the Instruction Fetch Unit (IFU) or produce memory requests. This includes uncacheable fetches.  An instruction fetch miss is counted only once and not once for every cycle it is outstanding.

**Table 19-13. Non-Architectural Performance Events  
in Processors Based on Intel Core Microarchitecture (Contd.)**

Event Num	Umask Value	Event Name	Definition	Description and Comment
82H	02H	ITLB.SMALL_MISS	ITLB small page misses	This event counts the number of instruction fetches from small pages that miss the ITLB.
82H	10H	ITLB.LARGE_MISS	ITLB large page misses	This event counts the number of instruction fetches from large pages that miss the ITLB.
82H	40H	ITLB.FLUSH	ITLB flushes	This event counts the number of ITLB flushes. This usually happens upon CR3 or CRO writes, which are executed by the operating system during process switches.
82H	12H	ITLB.MISSES	ITLB misses	This event counts the number of instruction fetches from either small or large pages that miss the ITLB.
83H	02H	INST_QUEUE.FULL	Cycles during which the instruction queue is full	This event counts the number of cycles during which the instruction queue is full. In this situation, the core front-end stops fetching more instructions. This is an indication of very long stalls in the back-end pipeline stages.
86H	00H	CYCLES_L1I_MEM_STALLED	Cycles during which instruction fetches stalled	This event counts the number of cycles for which an instruction fetch stalls, including stalls due to any of the following reasons: <ul style="list-style-type: none"> <li>▪ instruction Fetch Unit cache misses</li> <li>▪ instruction TLB misses</li> <li>▪ instruction TLB faults</li> </ul>
87H	00H	ILD_STALL	Instruction Length Decoder stall cycles due to a length changing prefix	This event counts the number of cycles during which the instruction length decoder uses the slow length decoder. Usually, instruction length decoding is done in one cycle. When the slow decoder is used, instruction decoding requires 6 cycles.



**Table 19-13. Non-Architectural Performance Events  
in Processors Based on Intel Core Microarchitecture (Contd.)**

Event Num	Umask Value	Event Name	Definition	Description and Comment
				<p>The slow decoder is used in the following cases:</p> <ul style="list-style-type: none"> <li>▪ operand override prefix (66H) preceding an instruction with immediate data</li> <li>▪ address override prefix (67H) preceding an instruction with a modr/m in real, big real, 16-bit protected or 32-bit protected modes</li> </ul> <p>To avoid instruction length decoding stalls, generate code using imm8 or imm32 values instead of imm16 values. If you must use an imm16 value, store the value in a register using "mov reg, imm32" and use the register format of the instruction.</p>
88H	00H	BR_INST_EXEC	Branch instructions executed	<p>This event counts all executed branches (not necessarily retired). This includes only instructions and not micro-op branches.</p> <p>Frequent branching is not necessarily a major performance issue. However frequent branch mispredictions may be a problem.</p>
89H	00H	BR_MISSP_EXEC	Mispredicted branch instructions executed	<p>This event counts the number of mispredicted branch instructions that were executed.</p>
8AH	00H	BR_BAC_MISSP_EXEC	Branch instructions mispredicted at decoding	<p>This event counts the number of branch instructions that were mispredicted at decoding.</p>
8BH	00H	BR_CND_EXEC	Conditional branch instructions executed.	<p>This event counts the number of conditional branch instructions executed, but not necessarily retired.</p>
8CH	00H	BR_CND_MISSP_EXEC	Mispredicted conditional branch instructions executed	<p>This event counts the number of mispredicted conditional branch instructions that were executed.</p>

**Table 19-13. Non-Architectural Performance Events  
in Processors Based on Intel Core Microarchitecture (Contd.)**

Event Num	Umask Value	Event Name	Definition	Description and Comment
8DH	00H	BR_IND_EXEC	Indirect branch instructions executed	This event counts the number of indirect branch instructions that were executed.
8EH	00H	BR_IND_MISSP_EXEC	Mispredicted indirect branch instructions executed	This event counts the number of mispredicted indirect branch instructions that were executed.
8FH	00H	BR_RET_EXEC	RET instructions executed	This event counts the number of RET instructions that were executed.
90H	00H	BR_RET_MISSP_EXEC	Mispredicted RET instructions executed	This event counts the number of mispredicted RET instructions that were executed.
91H	00H	BR_RET_BAC_MISSP_EXEC	RET instructions executed mispredicted at decoding	This event counts the number of RET instructions that were executed and were mispredicted at decoding.
92H	00H	BR_CALL_EXEC	CALL instructions executed	This event counts the number of CALL instructions executed.
93H	00H	BR_CALL_MISSP_EXEC	Mispredicted CALL instructions executed	This event counts the number of mispredicted CALL instructions that were executed.
94H	00H	BR_IND_CALL_EXEC	Indirect CALL instructions executed	This event counts the number of indirect CALL instructions that were executed.
97H	00H	BR_TKN_BUBBLE_1	Branch predicted taken with bubble 1	The events BR_TKN_BUBBLE_1 and BR_TKN_BUBBLE_2 together count the number of times a taken branch prediction incurred a one-cycle penalty. The penalty incurs when: <ul style="list-style-type: none"> <li>▪ Too many taken branches are placed together. To avoid this, unroll loops and add a non-taken branch in the middle of the taken sequence.</li> <li>▪ The branch target is unaligned. To avoid this, align the branch target.</li> </ul>

**Table 19-13. Non-Architectural Performance Events  
in Processors Based on Intel Core Microarchitecture (Contd.)**

Event Num	Umask Value	Event Name	Definition	Description and Comment
98H	00H	BR_TKN_BUBBLE_2	Branch predicted taken with bubble 2	The events BR_TKN_BUBBLE_1 and BR_TKN_BUBBLE_2 together count the number of times a taken branch prediction incurred a one-cycle penalty. The penalty incurs when: <ul style="list-style-type: none"> <li>Too many taken branches are placed together. To avoid this, unroll loops and add a non-taken branch in the middle of the taken sequence.</li> <li>The branch target is unaligned. To avoid this, align the branch target.</li> </ul>
A0H	00H	RS_UOPS_DISPATCHED	Micro-ops dispatched for execution	This event counts the number of micro-ops dispatched for execution. Up to six micro-ops can be dispatched in each cycle.
A1H	01H	RS_UOPS_DISPATCHED.PORT 0	Cycles micro-ops dispatched for execution on port 0	This event counts the number of cycles for which micro-ops dispatched for execution. Each cycle, at most one micro-op can be dispatched on the port. Issue Ports are described in <i>Intel® 64 and IA-32 Architectures Optimization Reference Manual</i> . Use IA32_PMC0 only.
A1H	02H	RS_UOPS_DISPATCHED.PORT 1	Cycles micro-ops dispatched for execution on port 1	This event counts the number of cycles for which micro-ops dispatched for execution. Each cycle, at most one micro-op can be dispatched on the port. Use IA32_PMC0 only.
A1H	04H	RS_UOPS_DISPATCHED.PORT 2	Cycles micro-ops dispatched for execution on port 2	This event counts the number of cycles for which micro-ops dispatched for execution. Each cycle, at most one micro-op can be dispatched on the port. Use IA32_PMC0 only.
A1H	08H	RS_UOPS_DISPATCHED.PORT 3	Cycles micro-ops dispatched for execution on port 3	This event counts the number of cycles for which micro-ops dispatched for execution. Each cycle, at most one micro-op can be dispatched on the port. Use IA32_PMC0 only.

**Table 19-13. Non-Architectural Performance Events  
in Processors Based on Intel Core Microarchitecture (Contd.)**

Event Num	Umask Value	Event Name	Definition	Description and Comment
A1H	10H	RS_UOPS_DISPATCHED.PORT 4	Cycles micro-ops dispatched for execution on port 4	This event counts the number of cycles for which micro-ops dispatched for execution. Each cycle, at most one micro-op can be dispatched on the port. Use IA32_PMC0 only.
A1H	20H	RS_UOPS_DISPATCHED.PORT 5	Cycles micro-ops dispatched for execution on port 5	This event counts the number of cycles for which micro-ops dispatched for execution. Each cycle, at most one micro-op can be dispatched on the port. Use IA32_PMC0 only.
AAH	01H	MACRO_INSTS. DECODED	Instructions decoded	This event counts the number of instructions decoded (but not necessarily executed or retired).
AAH	08H	MACRO_INSTS. CISC_DECODED	CISC Instructions decoded	This event counts the number of complex instructions decoded. Complex instructions usually have more than four micro-ops. Only one complex instruction can be decoded at a time.
ABH	01H	ESP.SYNCH	ESP register content synchronization	This event counts the number of times that the ESP register is explicitly used in the address expression of a load or store operation, after it is implicitly used, for example by a push or a pop instruction. ESP synch micro-op uses resources from the rename pipe-stage and up to retirement. The expected ratio of this event divided by the number of ESP implicit changes is 0,2. If the ratio is higher, consider rearranging your code to avoid ESP synchronization events.

**Table 19-13. Non-Architectural Performance Events  
in Processors Based on Intel Core Microarchitecture (Contd.)**

Event Num	Umask Value	Event Name	Definition	Description and Comment
ABH	02H	ESP.ADDITIONS	ESP register automatic additions	This event counts the number of ESP additions performed automatically by the decoder. A high count of this event is good, since each automatic addition performed by the decoder saves a micro-op from the execution units.  To maximize the number of ESP additions performed automatically by the decoder, choose instructions that implicitly use the ESP, such as PUSH, POP, CALL, and RET instructions whenever possible.
B0H	00H	SIMD_UOPS_EXEC	SIMD micro-ops executed (excluding stores)	This event counts all the SIMD micro-ops executed. It does not count MOVQ and MOVD stores from register to memory.
B1H	00H	SIMD_SAT_UOP_EXEC	SIMD saturated arithmetic micro-ops executed	This event counts the number of SIMD saturated arithmetic micro-ops executed.
B3H	01H	SIMD_UOP_TYPE_EXEC.MUL	SIMD packed multiply micro-ops executed	This event counts the number of SIMD packed multiply micro-ops executed.
B3H	02H	SIMD_UOP_TYPE_EXEC.SHIFT	SIMD packed shift micro-ops executed	This event counts the number of SIMD packed shift micro-ops executed.
B3H	04H	SIMD_UOP_TYPE_EXEC.PACK	SIMD pack micro-ops executed	This event counts the number of SIMD pack micro-ops executed.
B3H	08H	SIMD_UOP_TYPE_EXEC.UNPACK	SIMD unpack micro-ops executed	This event counts the number of SIMD unpack micro-ops executed.
B3H	10H	SIMD_UOP_TYPE_EXEC.LOGICAL	SIMD packed logical micro-ops executed	This event counts the number of SIMD packed logical micro-ops executed.
B3H	20H	SIMD_UOP_TYPE_EXEC.ARITHMETIC	SIMD packed arithmetic micro-ops executed	This event counts the number of SIMD packed arithmetic micro-ops executed.

**Table 19-13. Non-Architectural Performance Events  
in Processors Based on Intel Core Microarchitecture (Contd.)**

Event Num	Umask Value	Event Name	Definition	Description and Comment
COH	00H	INST_RETIRED. ANY_P	Instructions retired	This event counts the number of instructions that retire execution. For instructions that consist of multiple micro-ops, this event counts the retirement of the last micro-op of the instruction. The counter continue counting during hardware interrupts, traps, and inside interrupt handlers.  INST_RETIRED.ANY_P is an architectural performance event.
COH	01H	INST_RETIRED. LOADS	Instructions retired, which contain a load	This event counts the number of instructions retired that contain a load operation.
COH	02H	INST_RETIRED. STORES	Instructions retired, which contain a store	This event counts the number of instructions retired that contain a store operation.
COH	04H	INST_RETIRED. OTHER	Instructions retired, with no load or store operation	This event counts the number of instructions retired that do not contain a load or a store operation.
C1H	01H	X87_OPS_ RETIRED.FXCH	FXCH instructions retired	This event counts the number of FXCH instructions retired. Modern compilers generate more efficient code and are less likely to use this instruction. If you obtain a high count for this event consider recompiling the code.
C1H	FEH	X87_OPS_ RETIRED.ANY	Retired floating-point computational operations (precise event)	This event counts the number of floating-point computational operations retired. It counts: <ul style="list-style-type: none"> <li>▪ floating point computational operations executed by the assist handler</li> <li>▪ sub-operations of complex floating-point instructions like transcendental instructions</li> </ul>

**Table 19-13. Non-Architectural Performance Events  
in Processors Based on Intel Core Microarchitecture (Contd.)**

Event Num	Umask Value	Event Name	Definition	Description and Comment
				<p>This event does not count:</p> <ul style="list-style-type: none"> <li>▪ floating-point computational operations that cause traps or assists.</li> <li>▪ floating-point loads and stores.</li> </ul> <p>When this event is captured with the precise event mechanism, the collected samples contain the address of the instruction that was executed immediately after the instruction that caused the event.</p>
C2H	01H	UOPS_RETIRED. LD_IND_BR	Fused load+op or load+indirect branch retired	<p>This event counts the number of retired micro-ops that fused a load with another operation. This includes:</p> <ul style="list-style-type: none"> <li>▪ Fusion of a load and an arithmetic operation, such as with the following instruction: ADD EAX, [EBX] where the content of the memory location specified by EBX register is loaded, added to EXA register, and the result is stored in EAX.</li> <li>▪ Fusion of a load and a branch in an indirect branch operation, such as with the following instructions: <ul style="list-style-type: none"> <li>▪ JMP [RDI+200]</li> <li>▪ RET</li> </ul> </li> <li>▪ Fusion decreases the number of micro-ops in the processor pipeline. A high value for this event count indicates that the code is using the processor resources effectively.</li> </ul>
C2H	02H	UOPS_RETIRED. STD_STA	Fused store address + data retired	<p>This event counts the number of store address calculations that are fused with store data emission into one micro-op. Traditionally, each store operation required two micro-ops.</p> <p>This event counts fusion of retired micro-ops only. Fusion decreases the number of micro-ops in the processor pipeline. A high value for this event count indicates that the code is using the processor resources effectively.</p>

**Table 19-13. Non-Architectural Performance Events  
in Processors Based on Intel Core Microarchitecture (Contd.)**

Event Num	Umask Value	Event Name	Definition	Description and Comment
C2H	04H	UOPS_RETIRED.MACRO_FUSION	Retired instruction pairs fused into one micro-op	This event counts the number of times CMP or TEST instructions were fused with a conditional branch instruction into one micro-op. It counts fusion by retired micro-ops only.  Fusion decreases the number of micro-ops in the processor pipeline. A high value for this event count indicates that the code uses the processor resources more effectively.
C2H	07H	UOPS_RETIRED.FUSED	Fused micro-ops retired	This event counts the total number of retired fused micro-ops. The counts include the following fusion types: <ul style="list-style-type: none"> <li>▪ Fusion of load operation with an arithmetic operation or with an indirect branch (counted by event UOPS_RETIRED.LD_IND_BR)</li> <li>▪ Fusion of store address and data (counted by event UOPS_RETIRED.STD_STA)</li> <li>▪ Fusion of CMP or TEST instruction with a conditional branch instruction (counted by event UOPS_RETIRED.MACRO_FUSION)</li> </ul> Fusion decreases the number of micro-ops in the processor pipeline. A high value for this event count indicates that the code is using the processor resources effectively.
C2H	08H	UOPS_RETIRED.NON_FUSED	Non-fused micro-ops retired	This event counts the number of micro-ops retired that were not fused.
C2H	0FH	UOPS_RETIRED.ANY	Micro-ops retired	This event counts the number of micro-ops retired. The processor decodes complex macro instructions into a sequence of simpler micro-ops. Most instructions are composed of one or two micro-ops.



**Table 19-13. Non-Architectural Performance Events  
in Processors Based on Intel Core Microarchitecture (Contd.)**

Event Num	Umask Value	Event Name	Definition	Description and Comment
				Some instructions are decoded into longer sequences such as repeat instructions, floating point transcendental instructions, and assists. In some cases micro-op sequences are fused or whole instructions are fused into one micro-op. See other UOPS_RETIRED events for differentiating retired fused and non-fused micro-ops.
C3H	01H	MACHINE_NUKES.SMC	Self-Modifying Code detected	This event counts the number of times that a program writes to a code section. Self-modifying code causes a severe penalty in all Intel 64 and IA-32 processors.
C3H	04H	MACHINE_NUKES.MEM_ORDER	Execution pipeline restart due to memory ordering conflict or memory disambiguation misprediction	This event counts the number of times the pipeline is restarted due to either multi-threaded memory ordering conflicts or memory disambiguation misprediction. A multi-threaded memory ordering conflict occurs when a store, which is executed in another core, hits a load that is executed out of order in this core but not yet retired. As a result, the load needs to be restarted to satisfy the memory ordering model. See Chapter 8, "Multiple-Processor Management" in the <i>Intel® 64 and IA-32 Architectures Software Developer's Manual, Volume 3A</i> . To count memory disambiguation mispredictions, use the event MEMORY_DISAMBIGUATION.RESET.
C4H	00H	BR_INST_RETIRED.ANY	Retired branch instructions	This event counts the number of branch instructions retired. This is an architectural performance event.
C4H	01H	BR_INST_RETIRED.PRED_NOT_TAKEN	Retired branch instructions that were predicted not-taken	This event counts the number of branch instructions retired that were correctly predicted to be not-taken.

**Table 19-13. Non-Architectural Performance Events  
in Processors Based on Intel Core Microarchitecture (Contd.)**

Event Num	Umask Value	Event Name	Definition	Description and Comment
C4H	02H	BR_INST_RETIRED.MISPRED_NOT_TAKEN	Retired branch instructions that were mispredicted not-taken	This event counts the number of branch instructions retired that were mispredicted and not-taken.
C4H	04H	BR_INST_RETIRED.PRED_TAKEN	Retired branch instructions that were predicted taken	This event counts the number of branch instructions retired that were correctly predicted to be taken.
C4H	08H	BR_INST_RETIRED.MISPRED_TAKEN	Retired branch instructions that were mispredicted taken	This event counts the number of branch instructions retired that were mispredicted and taken.
C4H	0CH	BR_INST_RETIRED.TAKEN	Retired taken branch instructions	This event counts the number of branches retired that were taken.
C5H	00H	BR_INST_RETIRED.MISPRED	Retired mispredicted branch instructions. (precise event)	This event counts the number of retired branch instructions that were mispredicted by the processor. A branch misprediction occurs when the processor predicts that the branch would be taken, but it is not, or vice-versa.  This is an architectural performance event.
C6H	01H	CYCLES_INT_MASKED	Cycles during which interrupts are disabled	This event counts the number of cycles during which interrupts are disabled.
C6H	02H	CYCLES_INT_PENDING_AND_MASKED	Cycles during which interrupts are pending and disabled	This event counts the number of cycles during which there are pending interrupts but interrupts are disabled.
C7H	01H	SIMD_INST_RETIRED.PACKED_SINGLE	Retired SSE packed-single instructions	This event counts the number of SSE packed-single instructions retired.
C7H	02H	SIMD_INST_RETIRED.SCALAR_SINGLE	Retired SSE scalar-single instructions	This event counts the number of SSE scalar-single instructions retired.

**Table 19-13. Non-Architectural Performance Events  
in Processors Based on Intel Core Microarchitecture (Contd.)**

Event Num	Umask Value	Event Name	Definition	Description and Comment
C7H	04H	SIMD_INST_RETIRED.PACKED_DOUBLE	Retired SSE2 packed-double instructions	This event counts the number of SSE2 packed-double instructions retired.
C7H	08H	SIMD_INST_RETIRED.SCALAR_DOUBLE	Retired SSE2 scalar-double instructions	This event counts the number of SSE2 scalar-double instructions retired.
C7H	10H	SIMD_INST_RETIRED.VECTOR	Retired SSE2 vector integer instructions	This event counts the number of SSE2 vector integer instructions retired.
C7H	1FH	SIMD_INST_RETIRED.ANY	Retired Streaming SIMD instructions (precise event)	<p>This event counts the overall number of retired SIMD instructions that use XMM registers. To count each type of SIMD instruction separately, use the following events:</p> <ul style="list-style-type: none"> <li>▪ SIMD_INST_RETIRED.PACKED_SINGLE</li> <li>▪ SIMD_INST_RETIRED.SCALAR_SINGLE</li> <li>▪ SIMD_INST_RETIRED.PACKED_DOUBLE</li> <li>▪ SIMD_INST_RETIRED.SCALAR_DOUBLE</li> <li>▪ and SIMD_INST_RETIRED.VECTOR</li> </ul> <p>When this event is captured with the precise event mechanism, the collected samples contain the address of the instruction that was executed immediately after the instruction that caused the event.</p>
C8H	00H	HW_INT_RCV	Hardware interrupts received	This event counts the number of hardware interrupts received by the processor.
C9H	00H	ITLB_MISS_RETIRED	Retired instructions that missed the ITLB	This event counts the number of retired instructions that missed the ITLB when they were fetched.

**Table 19-13. Non-Architectural Performance Events  
in Processors Based on Intel Core Microarchitecture (Contd.)**

Event Num	Umask Value	Event Name	Definition	Description and Comment
CAH	01H	SIMD_COMP_INST_RETIREDPACKED_SINGLE	Retired computational SSE packed-single instructions	This event counts the number of computational SSE packed-single instructions retired. Computational instructions perform arithmetic computations (for example: add, multiply and divide).  Instructions that perform load and store operations or logical operations, like XOR, OR, and AND are not counted by this event.
CAH	02H	SIMD_COMP_INST_RETIREDSCALAR_SINGLE	Retired computational SSE scalar-single instructions	This event counts the number of computational SSE scalar-single instructions retired. Computational instructions perform arithmetic computations (for example: add, multiply and divide).  Instructions that perform load and store operations or logical operations, like XOR, OR, and AND are not counted by this event.
CAH	04H	SIMD_COMP_INST_RETIREDPACKED_DOUBLE	Retired computational SSE2 packed-double instructions	This event counts the number of computational SSE2 packed-double instructions retired. Computational instructions perform arithmetic computations (for example: add, multiply and divide).  Instructions that perform load and store operations or logical operations, like XOR, OR, and AND are not counted by this event.
CAH	08H	SIMD_COMP_INST_RETIREDSCALAR_DOUBLE	Retired computational SSE2 scalar-double instructions	This event counts the number of computational SSE2 scalar-double instructions retired. Computational instructions perform arithmetic computations (for example: add, multiply and divide).  Instructions that perform load and store operations or logical operations, like XOR, OR, and AND are not counted by this event.

**Table 19-13. Non-Architectural Performance Events  
in Processors Based on Intel Core Microarchitecture (Contd.)**

Event Num	Umask Value	Event Name	Definition	Description and Comment
CBH	01H	MEM_LOAD_RETIRE <sub>D</sub> .L1D_MISS	Retired loads that miss the L1 data cache (precise event)	<p>This event counts the number of retired load operations that missed the L1 data cache. This includes loads from cache lines that are currently being fetched, due to a previous L1 data cache miss to the same cache line.</p> <p>This event counts loads from cacheable memory only. The event does not count loads by software prefetches.</p> <p>When this event is captured with the precise event mechanism, the collected samples contain the address of the instruction that was executed immediately after the instruction that caused the event.</p> <p>Use IA32_PMC0 only.</p>
CBH	02H	MEM_LOAD_RETIRE <sub>D</sub> .L1D_LINE_MISS	L1 data cache line missed by retired loads (precise event)	<p>This event counts the number of load operations that miss the L1 data cache and send a request to the L2 cache to fetch the missing cache line. That is the missing cache line fetching has not yet started.</p> <p>The event count is equal to the number of cache lines fetched from the L2 cache by retired loads.</p> <p>This event counts loads from cacheable memory only. The event does not count loads by software prefetches.</p> <p>The event might not be counted if the load is blocked (see LOAD_BLOCK events).</p>
				<p>When this event is captured with the precise event mechanism, the collected samples contain the address of the instruction that was executed immediately after the instruction that caused the event.</p> <p>Use IA32_PMC0 only.</p>

**Table 19-13. Non-Architectural Performance Events  
in Processors Based on Intel Core Microarchitecture (Contd.)**

Event Num	Umask Value	Event Name	Definition	Description and Comment
CBH	04H	MEM_LOAD_RETIRED.L2_MISS	Retired loads that miss the L2 cache (precise event)	<p>This event counts the number of retired load operations that missed the L2 cache.</p> <p>This event counts loads from cacheable memory only. It does not count loads by software prefetches.</p> <p>When this event is captured with the precise event mechanism, the collected samples contain the address of the instruction that was executed immediately after the instruction that caused the event.</p> <p>Use IA32_PMC0 only.</p>
CBH	08H	MEM_LOAD_RETIRED.L2_LINE_MISS	L2 cache line missed by retired loads (precise event)	<p>This event counts the number of load operations that miss the L2 cache and result in a bus request to fetch the missing cache line. That is the missing cache line fetching has not yet started.</p> <p>This event count is equal to the number of cache lines fetched from memory by retired loads.</p> <p>This event counts loads from cacheable memory only. The event does not count loads by software prefetches.</p> <p>The event might not be counted if the load is blocked (see LOAD_BLOCK events).</p> <p>When this event is captured with the precise event mechanism, the collected samples contain the address of the instruction that was executed immediately after the instruction that caused the event.</p> <p>Use IA32_PMC0 only.</p>

**Table 19-13. Non-Architectural Performance Events  
in Processors Based on Intel Core Microarchitecture (Contd.)**

Event Num	Umask Value	Event Name	Definition	Description and Comment
CBH	10H	MEM_LOAD_RETIRED.DTLB_MISS	Retired loads that miss the DTLB (precise event)	<p>This event counts the number of retired loads that missed the DTLB. The DTLB miss is not counted if the load operation causes a fault.</p> <p>This event counts loads from cacheable memory only. The event does not count loads by software prefetches.</p> <p>When this event is captured with the precise event mechanism, the collected samples contain the address of the instruction that was executed immediately after the instruction that caused the event.</p> <p>Use IA32_PMC0 only.</p>
CCH	01H	FP_MMX_TRANS_TO_MMX	Transitions from Floating Point to MMX Instructions	This event counts the first MMX instructions following a floating-point instruction. Use this event to estimate the penalties for the transitions between floating-point and MMX states.
CCH	02H	FP_MMX_TRANS_TO_FP	Transitions from MMX Instructions to Floating Point Instructions	This event counts the first floating-point instructions following any MMX instruction. Use this event to estimate the penalties for the transitions between floating-point and MMX states.
CDH	00H	SIMD_ASSIST	SIMD assists invoked	This event counts the number of SIMD assists invoked. SIMD assists are invoked when an EMMS instruction is executed, changing the MMX state in the floating point stack.
CEH	00H	SIMD_INSTR_RETIRED	SIMD Instructions retired	This event counts the number of retired SIMD instructions that use MMX registers.
CFH	00H	SIMD_SAT_INSTR_RETIRED	Saturated arithmetic instructions retired	This event counts the number of saturated arithmetic SIMD instructions that retired.

**Table 19-13. Non-Architectural Performance Events  
in Processors Based on Intel Core Microarchitecture (Contd.)**

Event Num	Umask Value	Event Name	Definition	Description and Comment
D2H	01H	RAT_STALLS. ROB_READ_PORT	ROB read port stalls cycles	This event counts the number of cycles when ROB read port stalls occurred, which did not allow new micro-ops to enter the out-of-order pipeline.  Note that, at this stage in the pipeline, additional stalls may occur at the same cycle and prevent the stalled micro-ops from entering the pipe. In such a case, micro-ops retry entering the execution pipe in the next cycle and the ROB-read-port stall is counted again.
D2H	02H	RAT_STALLS. PARTIAL_CYCLES	Partial register stall cycles	This event counts the number of cycles instruction execution latency became longer than the defined latency because the instruction uses a register that was partially written by previous instructions.
D2H	04H	RAT_STALLS. FLAGS	Flag stall cycles	This event counts the number of cycles during which execution stalled due to several reasons, one of which is a partial flag register stall.  A partial register stall may occur when two conditions are met: <ul style="list-style-type: none"> <li>▪ an instruction modifies some, but not all, of the flags in the flag register</li> <li>▪ the next instruction, which depends on flags, depends on flags that were not modified by this instruction</li> </ul>
D2H	08H	RAT_STALLS. FPSW	FPU status word stall	This event indicates that the FPU status word (FPSW) is written. To obtain the number of times the FPSW is written divide the event count by 2.  The FPSW is written by instructions with long latency; a small count may indicate a high penalty.
D2H	0FH	RAT_STALLS. ANY	All RAT stall cycles	This event counts the number of stall cycles due to conditions described by: <ul style="list-style-type: none"> <li>▪ RAT_STALLS.ROB_READ_PORT</li> <li>▪ RAT_STALLS.PARTIAL</li> <li>▪ RAT_STALLS.FLAGS</li> <li>▪ RAT_STALLS.FPSW.</li> </ul>



**Table 19-13. Non-Architectural Performance Events  
in Processors Based on Intel Core Microarchitecture (Contd.)**

Event Num	Umask Value	Event Name	Definition	Description and Comment
D4H	01H	SEG_RENAME_STALLS.ES	Segment rename stalls - ES	This event counts the number of stalls due to the lack of renaming resources for the ES segment register. If a segment is renamed, but not retired and a second update to the same segment occurs, a stall occurs in the front-end of the pipeline until the renamed segment retires.
D4H	02H	SEG_RENAME_STALLS.DS	Segment rename stalls - DS	This event counts the number of stalls due to the lack of renaming resources for the DS segment register. If a segment is renamed, but not retired and a second update to the same segment occurs, a stall occurs in the front-end of the pipeline until the renamed segment retires.
D4H	04H	SEG_RENAME_STALLS.FS	Segment rename stalls - FS	This event counts the number of stalls due to the lack of renaming resources for the FS segment register.  If a segment is renamed, but not retired and a second update to the same segment occurs, a stall occurs in the front-end of the pipeline until the renamed segment retires.
D4H	08H	SEG_RENAME_STALLS.GS	Segment rename stalls - GS	This event counts the number of stalls due to the lack of renaming resources for the GS segment register.  If a segment is renamed, but not retired and a second update to the same segment occurs, a stall occurs in the front-end of the pipeline until the renamed segment retires.
D4H	0FH	SEG_RENAME_STALLS.ANY	Any (ES/DS/FS/GS) segment rename stall	This event counts the number of stalls due to the lack of renaming resources for the ES, DS, FS, and GS segment registers.  If a segment is renamed but not retired and a second update to the same segment occurs, a stall occurs in the front-end of the pipeline until the renamed segment retires.
D5H	01H	SEG_REG_RENAMES.ES	Segment renames - ES	This event counts the number of times the ES segment register is renamed.

**Table 19-13. Non-Architectural Performance Events  
in Processors Based on Intel Core Microarchitecture (Contd.)**

Event Num	Umask Value	Event Name	Definition	Description and Comment
D5H	02H	SEG_REG_RENAMES.DS	Segment renames - DS	This event counts the number of times the DS segment register is renamed.
D5H	04H	SEG_REG_RENAMES.FS	Segment renames - FS	This event counts the number of times the FS segment register is renamed.
D5H	08H	SEG_REG_RENAMES.GS	Segment renames - GS	This event counts the number of times the GS segment register is renamed.
D5H	0FH	SEG_REG_RENAMES.ANY	Any (ES/DS/FS/GS) segment rename	This event counts the number of times any of the four segment registers (ES/DS/FS/GS) is renamed.
DCH	01H	RESOURCE_STALLS.ROB_FULL	Cycles during which the ROB full	<p>This event counts the number of cycles when the number of instructions in the pipeline waiting for retirement reaches the limit the processor can handle.</p> <p>A high count for this event indicates that there are long latency operations in the pipe (possibly load and store operations that miss the L2 cache, and other instructions that depend on these cannot execute until the former instructions complete execution). In this situation new instructions can not enter the pipe and start execution.</p>
DCH	02H	RESOURCE_STALLS.RS_FULL	Cycles during which the RS full	<p>This event counts the number of cycles when the number of instructions in the pipeline waiting for execution reaches the limit the processor can handle.</p> <p>A high count of this event indicates that there are long latency operations in the pipe (possibly load and store operations that miss the L2 cache, and other instructions that depend on these cannot execute until the former instructions complete execution). In this situation new instructions can not enter the pipe and start execution.</p>

**Table 19-13. Non-Architectural Performance Events  
in Processors Based on Intel Core Microarchitecture (Contd.)**

Event Num	Umask Value	Event Name	Definition	Description and Comment
DCH	04	RESOURCE_STALLS.LD_ST	Cycles during which the pipeline has exceeded load or store limit or waiting to commit all stores	This event counts the number of cycles while resource-related stalls occur due to: <ul style="list-style-type: none"> <li>The number of load instructions in the pipeline reached the limit the processor can handle. The stall ends when a loading instruction retires.</li> <li>The number of store instructions in the pipeline reached the limit the processor can handle. The stall ends when a storing instruction commits its data to the cache or memory.</li> <li>There is an instruction in the pipe that can be executed only when all previous stores complete and their data is committed in the caches or memory. For example, the SFENCE and MFENCE instructions require this behavior.</li> </ul>
DCH	08H	RESOURCE_STALLS.FPCW	Cycles stalled due to FPU control word write	This event counts the number of cycles while execution was stalled due to writing the floating-point unit (FPU) control word.
DCH	10H	RESOURCE_STALLS.BR_MISS_CLEAR	Cycles stalled due to branch misprediction	This event counts the number of cycles after a branch misprediction is detected at execution until the branch and all older micro-ops retire. During this time new micro-ops cannot enter the out-of-order pipeline.
DCH	1FH	RESOURCE_STALLS.ANY	Resource related stalls	This event counts the number of cycles while resource-related stalls occurs for any conditions described by the following events: <ul style="list-style-type: none"> <li>RESOURCE_STALLS.ROB_FULL</li> <li>RESOURCE_STALLS.RS_FULL</li> <li>RESOURCE_STALLS.LD_ST</li> <li>RESOURCE_STALLS.FPCW</li> <li>RESOURCE_STALLS.BR_MISS_CLEAR</li> </ul>
EOH	00H	BR_INST_DECODED	Branch instructions decoded	This event counts the number of branch instructions decoded.

**Table 19-13. Non-Architectural Performance Events  
in Processors Based on Intel Core Microarchitecture (Contd.)**

Event Num	Umask Value	Event Name	Definition	Description and Comment
E4H	OOH	BOGUS_BR	Bogus branches	This event counts the number of byte sequences that were mistakenly detected as taken branch instructions.  This results in a BACLEAR event. This occurs mainly after task switches.
E6H	OOH	BACLEARs	BACLEARs asserted	This event counts the number of times the front end is resteeered, mainly when the BPU cannot provide a correct prediction and this is corrected by other branch handling mechanisms at the front and. This can occur if the code has many branches such that they cannot be consumed by the BPU.  Each BACLEAR asserted costs approximately 7 cycles of instruction fetch. The effect on total execution time depends on the surrounding code.
F0	OOH	PREF_RQSTS_UP	Upward prefetches issued from DPL	This event counts the number of upward prefetches issued from the Data Prefetch Logic (DPL) to the L2 cache. A prefetch request issued to the L2 cache cannot be cancelled and the requested cache line is fetched to the L2 cache.
F8	OOH	PREF_RQSTS_DN	Downward prefetches issued from DPL.	This event counts the number of downward prefetches issued from the Data Prefetch Logic (DPL) to the L2 cache. A prefetch request issued to the L2 cache cannot be cancelled and the requested cache line is fetched to the L2 cache.

## 19.8 PERFORMANCE MONITORING EVENTS FOR INTEL® ATOM™ PROCESSORS

Processors based on the Intel Atom microarchitecture support the architectural performance-monitoring events listed in Table 19-1 and fixed-function performance events using fixed counter listed in Table 19-12. In addition, they also support the following non-architectural performance-monitoring events listed in Table 19-14.

**Table 19-14. Non-Architectural Performance Events for Intel Atom Processors**

Event Num.	Umask Value	Event Name	Definition	Description and Comment
02H	81H	STORe_FORWA RDS.GOOD	Good store forwards	This event counts the number of times store data was forwarded directly to a load.
06H	00H	SEGMENT_REG_ LOADS.ANY	Number of segment register loads	<p>This event counts the number of segment register load operations. Instructions that load new values into segment registers cause a penalty. This event indicates performance issues in 16-bit code. If this event occurs frequently, it may be useful to calculate the number of instructions retired per segment register load. If the resulting calculation is low (on average a small number of instructions are executed between segment register loads), then the code's segment register usage should be optimized.</p> <p>As a result of branch misprediction, this event is speculative and may include segment register loads that do not actually occur. However, most segment register loads are internally serialized and such speculative effects are minimized.</p>
07H	01H	PREFETCH.PREF ETCHT0	Streaming SIMD Extensions (SSE) PrefetchT0 instructions executed.	This event counts the number of times the SSE instruction prefetchT0 is executed. This instruction prefetches the data to the L1 data cache and L2 cache.
07H	06H	PREFETCH.SW_ L2	Streaming SIMD Extensions (SSE) PrefetchT1 and PrefetchT2 instructions executed	This event counts the number of times the SSE instructions prefetchT1 and prefetchT2 are executed. These instructions prefetch the data to the L2 cache.
07H	08H	PREFETCH.PREF ETCHNTA	Streaming SIMD Extensions (SSE) Prefetch NTA instructions executed	This event counts the number of times the SSE instruction prefetchNTA is executed. This instruction prefetches the data to the L1 data cache.

**Table 19-14. Non-Architectural Performance Events for Intel Atom Processors**

Event Num.	Umask Value	Event Name	Definition	Description and Comment
08H	07H	DATA_TLB_MISSES.DTLB_MISS	Memory accesses that missed the DTLB	This event counts the number of Data Table Lookaside Buffer (DTLB) misses. The count includes misses detected as a result of speculative accesses. Typically a high count for this event indicates that the code accesses a large number of data pages.
08H	05H	DATA_TLB_MISSES.DTLB_MISS_LD	DTLB misses due to load operations	This event counts the number of Data Table Lookaside Buffer (DTLB) misses due to load operations. This count includes misses detected as a result of speculative accesses.
08H	09H	DATA_TLB_MISSES.LO_DTLB_MISS_LD	LO_DTLB misses due to load operations	This event counts the number of LO_DTLB misses due to load operations. This count includes misses detected as a result of speculative accesses.
08H	06H	DATA_TLB_MISSES.DTLB_MISS_ST	DTLB misses due to store operations	This event counts the number of Data Table Lookaside Buffer (DTLB) misses due to store operations. This count includes misses detected as a result of speculative accesses.
0CH	03H	PAGE_WALKS.WALKS	Number of page-walks executed	This event counts the number of page-walks executed due to either a DTLB or ITLB miss. The page walk duration, PAGE_WALKS.CYCLES, divided by number of page walks is the average duration of a page walk. This can hint to whether most of the page-walks are satisfied by the caches or cause an L2 cache miss. Edge trigger bit must be set.
0CH	03H	PAGE_WALKS.CYCLES	Duration of page-walks in core cycles	This event counts the duration of page-walks in core cycles. The paging mode in use typically affects the duration of page walks. Page walk duration divided by number of page walks is the average duration of page-walks. This can hint at whether most of the page-walks are satisfied by the caches or cause an L2 cache miss. Edge trigger bit must be cleared.
10H	01H	X87_COMP_OPS_EXE.ANY_S	Floating point computational micro-ops executed	This event counts the number of x87 floating point computational micro-ops executed.

**Table 19-14. Non-Architectural Performance Events for Intel Atom Processors**

Event Num.	Umask Value	Event Name	Definition	Description and Comment
10H	81H	X87_COMP_OPS_EXE.ANY.AR	Floating point computational micro-ops retired	This event counts the number of x87 floating point computational micro-ops retired.
11H	01H	FP_ASSIST	Floating point assists	This event counts the number of floating point operations executed that required micro-code assist intervention. These assists are required in the following cases: X87 instructions: 1. NaN or denormal are loaded to a register or used as input from memory 2. Division by 0 3. Underflow output
11H	81H	FP_ASSIST.AR	Floating point assists	This event counts the number of floating point operations executed that required micro-code assist intervention. These assists are required in the following cases: X87 instructions: 1. NaN or denormal are loaded to a register or used as input from memory 2. Division by 0 3. Underflow output
12H	01H	MUL.S	Multiply operations executed	This event counts the number of multiply operations executed. This includes integer as well as floating point multiply operations.
12H	81H	MUL.AR	Multiply operations retired	This event counts the number of multiply operations retired. This includes integer as well as floating point multiply operations.
13H	01H	DIV.S	Divide operations executed	This event counts the number of divide operations executed. This includes integer divides, floating point divides and square-root operations executed.
13H	81H	DIV.AR	Divide operations retired	This event counts the number of divide operations retired. This includes integer divides, floating point divides and square-root operations executed.

**Table 19-14. Non-Architectural Performance Events for Intel Atom Processors**

Event Num.	Umask Value	Event Name	Definition	Description and Comment
14H	01H	CYCLES_DIV_BUSY	Cycles the divider is busy	This event counts the number of cycles the divider is busy executing divide or square root operations. The divide can be integer, X87 or Streaming SIMD Extensions (SSE). The square root operation can be either X87 or SSE.
21H	See Table 18-2	L2_ADS	Cycles L2 address bus is in use	This event counts the number of cycles the L2 address bus is being used for accesses to the L2 cache or bus queue. This event can count occurrences for this core or both cores.
22H	See Table 18-2	L2_DBUS_BUSY	Cycles the L2 cache data bus is busy	This event counts core cycles during which the L2 cache data bus is busy transferring data from the L2 cache to the core. It counts for all L1 cache misses (data and instruction) that hit the L2 cache. The count will increment by two for a full cache-line request.
24H	See Table 18-2 and Table 18-4	L2_LINES_IN	L2 cache misses	This event counts the number of cache lines allocated in the L2 cache. Cache lines are allocated in the L2 cache as a result of requests from the L1 data and instruction caches and the L2 hardware prefetchers to cache lines that are missing in the L2 cache. This event can count occurrences for this core or both cores. This event can also count demand requests and L2 hardware prefetch requests together or separately.
25H	See Table 18-2	L2_M_LINES_IN	L2 cache line modifications	This event counts whenever a modified cache line is written back from the L1 data cache to the L2 cache. This event can count occurrences for this core or both cores.
26H	See Table 18-2 and Table 18-4	L2_LINES_OUT	L2 cache lines evicted	This event counts the number of L2 cache lines evicted. This event can count occurrences for this core or both cores. This event can also count evictions due to demand requests and L2 hardware prefetch requests together or separately.



**Table 19-14. Non-Architectural Performance Events for Intel Atom Processors**

Event Num.	Umask Value	Event Name	Definition	Description and Comment
27H	See Table 18-2 and Table 18-4	L2_M_LINES_0 UT	Modified lines evicted from the L2 cache	This event counts the number of L2 modified cache lines evicted. These lines are written back to memory unless they also exist in a shared-state in one of the L1 data caches.  This event can count occurrences for this core or both cores. This event can also count evictions due to demand requests and L2 hardware prefetch requests together or separately.
28H	See Table 18-2 and Table 18-5	L2_IFETCH	L2 cacheable instruction fetch requests	This event counts the number of instruction cache line requests from the ICache. It does not include fetch requests from uncacheable memory. It does not include ITLB miss accesses.  This event can count occurrences for this core or both cores. This event can also count accesses to cache lines at different MESI states.
29H	See Table 18-2, Table 18-4 and Table 18-5	L2_LD	L2 cache reads	This event counts L2 cache read requests coming from the L1 data cache and L2 prefetchers.  This event can count occurrences for this core or both cores. This event can count occurrences <ul style="list-style-type: none"> <li>- for this core or both cores.</li> <li>- due to demand requests and L2 hardware prefetch requests together or separately.</li> <li>- of accesses to cache lines at different MESI states.</li> </ul>
2AH	See Table 18-2 and Table 18-5	L2_ST	L2 store requests	This event counts all store operations that miss the L1 data cache and request the data from the L2 cache.  This event can count occurrences for this core or both cores. This event can also count accesses to cache lines at different MESI states.

**Table 19-14. Non-Architectural Performance Events for Intel Atom Processors**

Event Num.	Umask Value	Event Name	Definition	Description and Comment
2BH	See Table 18-2 and Table 18-5	L2_LOCK	L2 locked accesses	This event counts all locked accesses to cache lines that miss the L1 data cache. This event can count occurrences for this core or both cores. This event can also count accesses to cache lines at different MESI states.
2EH	See Table 18-2, Table 18-4 and Table 18-5	L2_RQSTS	L2 cache requests	This event counts all completed L2 cache requests. This includes L1 data cache reads, writes, and locked accesses, L1 data prefetch requests, instruction fetches, and all L2 hardware prefetch requests. This event can count occurrences - for this core or both cores. - due to demand requests and L2 hardware prefetch requests together, or separately. - of accesses to cache lines at different MESI states.
2EH	41H	L2_RQSTS.SELF.DEMAND.I_STAT E	L2 cache demand requests from this core that missed the L2	This event counts all completed L2 cache demand requests from this core that miss the L2 cache. This includes L1 data cache reads, writes, and locked accesses, L1 data prefetch requests, and instruction fetches. <b>This is an architectural performance event.</b>
2EH	4FH	L2_RQSTS.SELF.DEMAND.MESI	L2 cache demand requests from this core	This event counts all completed L2 cache demand requests from this core. This includes L1 data cache reads, writes, and locked accesses, L1 data prefetch requests, and instruction fetches. <b>This is an architectural performance event.</b>

**Table 19-14. Non-Architectural Performance Events for Intel Atom Processors**

Event Num.	Umask Value	Event Name	Definition	Description and Comment
30H	See Table 18-2, Table 18-4 and Table 18-5	L2_REJECT_BUS Q	Rejected L2 cache requests	<p>This event indicates that a pending L2 cache request that requires a bus transaction is delayed from moving to the bus queue. Some of the reasons for this event are:</p> <ul style="list-style-type: none"> <li>- The bus queue is full.</li> <li>- The bus queue already holds an entry for a cache line in the same set.</li> </ul> <p>The number of events is greater or equal to the number of requests that were rejected.</p> <ul style="list-style-type: none"> <li>- for this core or both cores.</li> <li>- due to demand requests and L2 hardware prefetch requests together, or separately.</li> <li>- of accesses to cache lines at different MESI states.</li> </ul>
32H	See Table 18-2	L2_NO_REQ	Cycles no L2 cache requests are pending	This event counts the number of cycles that no L2 cache requests are pending.
3AH	00H	EIST_TRANS	Number of Enhanced Intel SpeedStep(R) Technology (EIST) transitions	This event counts the number of Enhanced Intel SpeedStep(R) Technology (EIST) transitions that include a frequency change, either with or without VID change. This event is incremented only while the counting core is in C0 state. Since the CxE states include an EIST transition, the event will be incremented accordingly.
				EIST transitions are commonly initiated by OS, but can be initiated by HW internally. For example: CxE states are C-states (C1,C2,C3...) which not only place the CPU into a sleep state by turning off the clock and other components, but also lower the voltage (which reduces the leakage power consumption). The same is true for thermal throttling transition which uses EIST internally.

**Table 19-14. Non-Architectural Performance Events for Intel Atom Processors**

Event Num.	Unmask Value	Event Name	Definition	Description and Comment
3BH	COH	THERMAL_TRIP	Number of thermal trips	This event counts the number of thermal trips. A thermal trip occurs whenever the processor temperature exceeds the thermal trip threshold temperature. Following a thermal trip, the processor automatically reduces frequency and voltage. The processor checks the temperature every millisecond, and returns to normal when the temperature falls below the thermal trip threshold temperature.
3CH	OOH	CPU_CLK_UNHALTED.CORE_P	Core cycles when core is not halted	<p>This event counts the number of core cycles while the core is not in a halt state. The core enters the halt state when it is running the HLT instruction. This event is a component in many key event ratios.</p> <p>In mobile systems the core frequency may change from time to time. For this reason this event may have a changing ratio with regards to time. In systems with a constant core frequency, this event can give you a measurement of the elapsed time while the core was not in halt state by dividing the event count by the core frequency.</p> <ul style="list-style-type: none"> <li>-This is an architectural performance event.</li> <li>- The event CPU_CLK_UNHALTED.CORE_P is counted by a programmable counter.</li> <li>- The event CPU_CLK_UNHALTED.CORE is counted by a designated fixed counter, leaving the two programmable counters available for other events.</li> </ul>

**Table 19-14. Non-Architectural Performance Events for Intel Atom Processors**

Event Num.	Umask Value	Event Name	Definition	Description and Comment
3CH	01H	CPU_CLK_UNHALTED.BUS	Bus cycles when core is not halted	<p>This event counts the number of bus cycles while the core is not in the halt state. This event can give you a measurement of the elapsed time while the core was not in the halt state, by dividing the event count by the bus frequency. The core enters the halt state when it is running the HLT instruction.</p> <p>The event also has a constant ratio with CPU_CLK_UNHALTED.REF event, which is the maximum bus to processor frequency ratio. Non-halted bus cycles are a component in many key event ratios.</p>
3CH	02H	CPU_CLK_UNHALTED.NO_OTHER	Bus cycles when core is active and the other is halted	<p>This event counts the number of bus cycles during which the core remains non-halted, and the other core on the processor is halted.</p> <p>This event can be used to determine the amount of parallelism exploited by an application or a system. Divide this event count by the bus frequency to determine the amount of time that only one core was in use.</p>
40H	21H	L1D_CACHE.LD	L1 Cacheable Data Reads	This event counts the number of data reads from cacheable memory.
40H	22H	L1D_CACHE.ST	L1 Cacheable Data Writes	This event counts the number of data writes to cacheable memory.
60H	See Table 18-2 and Table 18-3	BUS_REQUEST_OUTSTANDING	Outstanding cacheable data read bus requests duration	This event counts the number of pending full cache line read transactions on the bus occurring in each cycle. A read transaction is pending from the cycle it is sent on the bus until the full cache line is received by the processor. NOTE: This event is thread-independent and will not provide a count per logical processor when AnyThr is disabled.

**Table 19-14. Non-Architectural Performance Events for Intel Atom Processors**

Event Num.	Umask Value	Event Name	Definition	Description and Comment
61H	See Table 18-3	BUS_BNR_DRV	Number of Bus Not Ready signals asserted	<p>This event counts the number of Bus Not Ready (BNR) signals that the processor asserts on the bus to suspend additional bus requests by other bus agents. A bus agent asserts the BNR signal when the number of data and snoop transactions is close to the maximum that the bus can handle.</p> <p>While this signal is asserted, new transactions cannot be submitted on the bus. As a result, transaction latency may have higher impact on program performance.</p> <p>NOTE: This event is thread-independent and will not provide a count per logical processor when AnyThr is disabled.</p>
62H	See Table 18-3	BUS_DRDY_CLO CKS	Bus cycles when data is sent on the bus	<p>This event counts the number of bus cycles during which the DRDY (Data Ready) signal is asserted on the bus. The DRDY signal is asserted when data is sent on the bus.</p> <p>This event counts the number of bus cycles during which this agent (the processor) writes data on the bus back to memory or to other bus agents. This includes all explicit and implicit data writebacks, as well as partial writes.</p> <p>NOTE: This event is thread-independent and will not provide a count per logical processor when AnyThr is disabled.</p>
63H	See Table 18-2 and Table 18-3	BUS_LOCK_CLO CKS	Bus cycles when a LOCK signal is asserted.	<p>This event counts the number of bus cycles, during which the LOCK signal is asserted on the bus. A LOCK signal is asserted when there is a locked memory access, due to:</p> <ul style="list-style-type: none"> <li>- Uncacheable memory</li> <li>- Locked operation that spans two cache lines</li> <li>- Page-walk from an uncacheable page table.</li> </ul> <p>Bus locks have a very high performance penalty and it is highly recommended to avoid such accesses. NOTE: This event is thread-independent and will not provide a count per logical processor when AnyThr is disabled.</p>

**Table 19-14. Non-Architectural Performance Events for Intel Atom Processors**

Event Num.	Umask Value	Event Name	Definition	Description and Comment
64H	See Table 18-2	BUS_DATA_RCV	Bus cycles while processor receives data	This event counts the number of cycles during which the processor is busy receiving data. NOTE: This event is thread-independent and will not provide a count per logical processor when AnyThr is disabled.
65H	See Table 18-2 and Table 18-3	BUS_TRANS_BRD	Burst read bus transactions	This event counts the number of burst read transactions including: <ul style="list-style-type: none"> <li>- L1 data cache read misses (and L1 data cache hardware prefetches)</li> <li>- L2 hardware prefetches by the DPL and L2 streamer</li> <li>- IFU read misses of cacheable lines.</li> </ul> It does not include RFO transactions.
66H	See Table 18-2 and Table 18-3	BUS_TRANS_RFO	RFO bus transactions	This event counts the number of Read For Ownership (RFO) bus transactions, due to store operations that miss the L1 data cache and the L2 cache. This event also counts RFO bus transactions due to locked operations.
67H	See Table 18-2 and Table 18-3	BUS_TRANS_WB	Explicit writeback bus transactions	This event counts all explicit writeback bus transactions due to dirty line evictions. It does not count implicit writebacks due to invalidation by a snoop request.
68H	See Table 18-2 and Table 18-3	BUS_TRANS_IFETCH	Instruction-fetch bus transactions.	This event counts all instruction fetch full cache line bus transactions.
69H	See Table 18-2 and Table 18-3	BUS_TRANS_INVALID	Invalidate bus transactions	This event counts all invalidate transactions. Invalidate transactions are generated when: <ul style="list-style-type: none"> <li>- A store operation hits a shared line in the L2 cache.</li> <li>- A full cache line write misses the L2 cache or hits a shared line in the L2 cache.</li> </ul>

**Table 19-14. Non-Architectural Performance Events for Intel Atom Processors**

Event Num.	Umask Value	Event Name	Definition	Description and Comment
6AH	See Table 18-2 and Table 18-3	BUS_TRANS_P WR	Partial write bus transaction.	This event counts partial write bus transactions.
6BH	See Table 18-2 and Table 18-3	BUS_TRANS_P	Partial bus transactions	This event counts all (read and write) partial bus transactions.
6CH	See Table 18-2 and Table 18-3	BUS_TRANS_IO	IO bus transactions	This event counts the number of completed I/O bus transactions as a result of IN and OUT instructions. The count does not include memory mapped IO.
6DH	See Table 18-2 and Table 18-3	BUS_TRANS_D EF	Deferred bus transactions	This event counts the number of deferred transactions.
6EH	See Table 18-2 and Table 18-3	BUS_TRANS_B URST	Burst (full cache-line) bus transactions.	This event counts burst (full cache line) transactions including: <ul style="list-style-type: none"> <li>- Burst reads</li> <li>- RFOs</li> <li>- Explicit writebacks</li> <li>- Write combine lines</li> </ul>
6FH	See Table 18-2 and Table 18-3	BUS_TRANS_M EM	Memory bus transactions	This event counts all memory bus transactions including: <ul style="list-style-type: none"> <li>- burst transactions</li> <li>- partial reads and writes</li> <li>- invalidate transactions</li> </ul> The BUS_TRANS_MEM count is the sum of BUS_TRANS_BURST, BUS_TRANS_P and BUS_TRANS_INVAL.



**Table 19-14. Non-Architectural Performance Events for Intel Atom Processors**

Event Num.	Umask Value	Event Name	Definition	Description and Comment
70H	See Table 18-2 and Table 18-3	BUS_TRANS_ANY	All bus transactions	This event counts all bus transactions. This includes: <ul style="list-style-type: none"> <li>- Memory transactions</li> <li>- IO transactions (non memory-mapped)</li> <li>- Deferred transaction completion</li> <li>- Other less frequent transactions, such as interrupts</li> </ul>
77H	See Table 18-2 and Table 18-5	EXT_SNOOP	External snoops	This event counts the snoop responses to bus transactions. Responses can be counted separately by type and by bus agent. NOTE: This event is thread-independent and will not provide a count per logical processor when AnyThr is disabled.
7AH	See Table 18-3	BUS_HIT_DRV	HIT signal asserted	This event counts the number of bus cycles during which the processor drives the HIT# pin to signal HIT snoop response. NOTE: This event is thread-independent and will not provide a count per logical processor when AnyThr is disabled.
7BH	See Table 18-3	BUS_HITM_DRV	HITM signal asserted	This event counts the number of bus cycles during which the processor drives the HITM# pin to signal HITM snoop response. NOTE: This event is thread-independent and will not provide a count per logical processor when AnyThr is disabled.
7DH	See Table 18-2	BUSQ_EMPTY	Bus queue is empty	This event counts the number of cycles during which the core did not have any pending transactions in the bus queue. <b>NOTE:</b> This event is thread-independent and will not provide a count per logical processor when AnyThr is disabled.
7EH	See Table 18-2 and Table 18-3	SNOOP_STALL_DRV	Bus stalled for snoops	This event counts the number of times that the bus snoop stall signal is asserted. During the snoop stall cycles no new bus transactions requiring a snoop response can be initiated on the bus. NOTE: This event is thread-independent and will not provide a count per logical processor when AnyThr is disabled.

**Table 19-14. Non-Architectural Performance Events for Intel Atom Processors**

Event Num.	Umask Value	Event Name	Definition	Description and Comment
7FH	See Table 18-2	BUS_IO_WAIT	IO requests waiting in the bus queue	This event counts the number of core cycles during which IO requests wait in the bus queue. This event counts IO requests from the core.
80H	03H	ICACHE.ACCESSES	Instruction fetches	This event counts all instruction fetches, including uncacheable fetches.
80H	02H	ICACHE.MISSES	lcache miss	This event counts all instruction fetches that miss the Instruction cache or produce memory requests. This includes uncacheable fetches. An instruction fetch miss is counted only once and not once for every cycle it is outstanding.
82H	04H	ITLB.FLUSH	ITLB flushes	This event counts the number of ITLB flushes.
82H	02H	ITLB.MISSES	ITLB misses	This event counts the number of instruction fetches that miss the ITLB.
AAH	02H	MACRO_INSTS.CISC_DECODED	CISC macro instructions decoded	This event counts the number of complex instructions decoded, but not necessarily executed or retired. Only one complex instruction can be decoded at a time.
AAH	03H	MACRO_INSTS.ALL_DECODED	All Instructions decoded	This event counts the number of instructions decoded.
BOH	00H	SIMD_UOPS_EXEC.S	SIMD micro-ops executed (excluding stores)	This event counts all the SIMD micro-ops executed. This event does not count MOVQ and MOVD stores from register to memory.
BOH	80H	SIMD_UOPS_EXEC.AR	SIMD micro-ops retired (excluding stores)	This event counts the number of SIMD saturated arithmetic micro-ops executed.
B1H	00H	SIMD_SAT_UOP_EXEC.S	SIMD saturated arithmetic micro-ops executed	This event counts the number of SIMD saturated arithmetic micro-ops executed.
B1H	80H	SIMD_SAT_UOP_EXEC.AR	SIMD saturated arithmetic micro-ops retired	This event counts the number of SIMD saturated arithmetic micro-ops retired.

**Table 19-14. Non-Architectural Performance Events for Intel Atom Processors**

Event Num.	Umask Value	Event Name	Definition	Description and Comment
B3H	01H	SIMD_UOP_TYPER_EXEC.MULS	SIMD packed multiply micro-ops executed	This event counts the number of SIMD packed multiply micro-ops executed.
B3H	81H	SIMD_UOP_TYPER_EXEC.MULAR	SIMD packed multiply micro-ops retired	This event counts the number of SIMD packed multiply micro-ops retired.
B3H	02H	SIMD_UOP_TYPER_EXEC.SHIFTS	SIMD packed shift micro-ops executed	This event counts the number of SIMD packed shift micro-ops executed.
B3H	82H	SIMD_UOP_TYPER_EXEC.SHIFTSAR	SIMD packed shift micro-ops retired	This event counts the number of SIMD packed shift micro-ops retired.
B3H	04H	SIMD_UOP_TYPER_EXEC.PACKS	SIMD pack micro-ops executed	This event counts the number of SIMD pack micro-ops executed.
B3H	84H	SIMD_UOP_TYPER_EXEC.PACKSAR	SIMD pack micro-ops retired	This event counts the number of SIMD pack micro-ops retired.
B3H	08H	SIMD_UOP_TYPER_EXEC.UNPACKS	SIMD unpack micro-ops executed	This event counts the number of SIMD unpack micro-ops executed.
B3H	88H	SIMD_UOP_TYPER_EXEC.UNPACKSAR	SIMD unpack micro-ops retired	This event counts the number of SIMD unpack micro-ops retired.
B3H	10H	SIMD_UOP_TYPER_EXEC.LOGICALS	SIMD packed logical micro-ops executed	This event counts the number of SIMD packed logical micro-ops executed.
B3H	90H	SIMD_UOP_TYPER_EXEC.LOGICALSAR	SIMD packed logical micro-ops retired	This event counts the number of SIMD packed logical micro-ops retired.
B3H	20H	SIMD_UOP_TYPER_EXEC.ARITHMETICS	SIMD packed arithmetic micro-ops executed	This event counts the number of SIMD packed arithmetic micro-ops executed.
B3H	A0H	SIMD_UOP_TYPER_EXEC.ARITHMETICSAR	SIMD packed arithmetic micro-ops retired	This event counts the number of SIMD packed arithmetic micro-ops retired.

**Table 19-14. Non-Architectural Performance Events for Intel Atom Processors**

Event Num.	Umask Value	Event Name	Definition	Description and Comment
C0H	00H	INST_RETIRED.ANY_P	Instructions retired (precise event).	This event counts the number of instructions that retire execution. For instructions that consist of multiple micro-ops, this event counts the retirement of the last micro-op of the instruction. The counter continues counting during hardware interrupts, traps, and inside interrupt handlers.
N/A	00H	INST_RETIRED.ANY	Instructions retired	This event counts the number of instructions that retire execution. For instructions that consist of multiple micro-ops, this event counts the retirement of the last micro-op of the instruction. The counter continues counting during hardware interrupts, traps, and inside interrupt handlers.
C2H	10H	UOPS_RETIRED.ANY	Micro-ops retired	This event counts the number of micro-ops retired. The processor decodes complex macro instructions into a sequence of simpler micro-ops. Most instructions are composed of one or two micro-ops. Some instructions are decoded into longer sequences such as repeat instructions, floating point transcendental instructions, and assists. In some cases micro-op sequences are fused or whole instructions are fused into one micro-op. See other UOPS_RETIRED events for differentiating retired fused and non-fused micro-ops.
C3H	01H	MACHINE_CLEARS.SMC	Self-Modifying Code detected	This event counts the number of times that a program writes to a code section. Self-modifying code causes a severe penalty in all Intel® architecture processors.
C4H	00H	BR_INST_RETIRED.ANY	Retired branch instructions	This event counts the number of branch instructions retired. <b>This is an architectural performance event.</b>
C4H	01H	BR_INST_RETIRED.PRED_NOT_TAKEN	Retired branch instructions that were predicted not-taken	This event counts the number of branch instructions retired that were correctly predicted to be not-taken.

**Table 19-14. Non-Architectural Performance Events for Intel Atom Processors**

Event Num.	Umask Value	Event Name	Definition	Description and Comment
C4H	02H	BR_INST_RETIREDMISPRED_NOT_TAKEN	Retired branch instructions that were mispredicted not-taken	This event counts the number of branch instructions retired that were mispredicted and not-taken.
C4H	04H	BR_INST_RETIREDPRED_TAKEN	Retired branch instructions that were predicted taken	This event counts the number of branch instructions retired that were correctly predicted to be taken.
C4H	08H	BR_INST_RETIREDMISPRED_TAKEN	Retired branch instructions that were mispredicted taken	This event counts the number of branch instructions retired that were mispredicted and taken.
C4H	0AH	BR_INST_RETIREDMISPRED	Retired mispredicted branch instructions (precise event)	<p>This event counts the number of retired branch instructions that were mispredicted by the processor. A branch misprediction occurs when the processor predicts that the branch would be taken, but it is not, or vice-versa. Mispredicted branches degrade the performance because the processor starts executing instructions along a wrong path it predicts. When the misprediction is discovered, all the instructions executed in the wrong path must be discarded, and the processor must start again on the correct path.</p> <p>Using the Profile-Guided Optimization (PGO) features of the Intel® C++ compiler may help reduce branch mispredictions. See the compiler documentation for more information on this feature.</p>

**Table 19-14. Non-Architectural Performance Events for Intel Atom Processors**

Event Num.	Umask Value	Event Name	Definition	Description and Comment
				<p>To determine the branch misprediction ratio, divide the BR_INST_RETIRED.MISPRED event count by the number of BR_INST_RETIRED.ANY event count. To determine the number of mispredicted branches per instruction, divide the number of mispredicted branches by the INST_RETIRED.ANY event count. To measure the impact of the branch mispredictions use the event RESOURCE_STALLS.BR_MISS_CLEAR.</p> <p><b>Tips</b></p> <ul style="list-style-type: none"> <li>- See the optimization guide for tips on reducing branch mispredictions.</li> <li>- PGO's purpose is to have straight line code for the most frequent execution paths, reducing branches taken and increasing the "basic block" size, possibly also reducing the code footprint or working-set.</li> </ul>
C4H	OCH	BR_INST_RETIRED.TAKEN	Retired taken branch instructions	This event counts the number of branches retired that were taken.
C4H	OFH	BR_INST_RETIRED.ANY1	Retired branch instructions	This event counts the number of branch instructions retired that were mispredicted. This event is a duplicate of BR_INST_RETIRED.MISPRED.
C5H	OOH	BR_INST_RETIRED.MISPRED	Retired mispredicted branch instructions (precise event).	This event counts the number of retired branch instructions that were mispredicted by the processor. A branch misprediction occurs when the processor predicts that the branch would be taken, but it is not, or vice-versa. Mispredicted branches degrade the performance because the processor starts executing instructions along a wrong path it predicts. When the misprediction is discovered, all the instructions executed in the wrong path must be discarded, and the processor must start again on the correct path.

Table 19-14. Non-Architectural Performance Events for Intel Atom Processors

Event Num.	Umask Value	Event Name	Definition	Description and Comment
				<p>Using the Profile-Guided Optimization (PGO) features of the Intel® C++ compiler may help reduce branch mispredictions. See the compiler documentation for more information on this feature.</p> <p>To determine the branch misprediction ratio, divide the BR_INST_RETIRED.MISPRED event count by the number of BR_INST_RETIRED.ANY event count. To determine the number of mispredicted branches per instruction, divide the number of mispredicted branches by the INST_RETIRED.ANY event count. To measure the impact of the branch mispredictions use the event RESOURCE_STALLS.BR_MISS_CLEAR.</p> <p><b>Tips</b></p> <ul style="list-style-type: none"> <li>- See the optimization guide for tips on reducing branch mispredictions.</li> <li>- PGO's purpose is to have straight line code for the most frequent execution paths, reducing branches taken and increasing the "basic block" size, possibly also reducing the code footprint or working-set.</li> </ul>
C6H	01H	CYCLES_INT_MASKED.CYCLES_INT_MASKED	Cycles during which interrupts are disabled	This event counts the number of cycles during which interrupts are disabled.
C6H	02H	CYCLES_INT_PENDING_AND_MASKED.CYCLES_INT_PENDING_AND_MASKED	Cycles during which interrupts are pending and disabled	This event counts the number of cycles during which there are pending interrupts but interrupts are disabled.
C7H	01H	SIMD_INST_RETIRED.PACKED_SINGLE	Retired Streaming SIMD Extensions (SSE) packed-single instructions	This event counts the number of SSE packed-single instructions retired.

**Table 19-14. Non-Architectural Performance Events for Intel Atom Processors**

Event Num.	Umask Value	Event Name	Definition	Description and Comment
C7H	02H	SIMD_INST_RETIRED.SCALAR_SINGLE	Retired Streaming SIMD Extensions (SSE) scalar-single instructions	This event counts the number of SSE scalar-single instructions retired.
C7H	04H	SIMD_INST_RETIRED.PACKED_DOUBLE	Retired Streaming SIMD Extensions 2 (SSE2) packed-double instructions	This event counts the number of SSE2 packed-double instructions retired.
C7H	08H	SIMD_INST_RETIRED.SCALAR_DOUBLE	Retired Streaming SIMD Extensions 2 (SSE2) scalar-double instructions.	This event counts the number of SSE2 scalar-double instructions retired.
C7H	10H	SIMD_INST_RETIRED.VECTOR	Retired Streaming SIMD Extensions 2 (SSE2) vector instructions.	This event counts the number of SSE2 vector instructions retired.
C7H	1FH	SIMD_INST_RETIRED.ANY	Retired Streaming SIMD instructions	This event counts the overall number of SIMD instructions retired. To count each type of SIMD instruction separately, use the following events: SIMD_INST_RETIRED.PACKED_SINGLE, SIMD_INST_RETIRED.SCALAR_SINGLE, SIMD_INST_RETIRED.PACKED_DOUBLE, SIMD_INST_RETIRED.SCALAR_DOUBLE, and SIMD_INST_RETIRED.VECTOR.
C8H	00H	HW_INT_RCV	Hardware interrupts received	This event counts the number of hardware interrupts received by the processor. This event will count twice for dual-pipe micro-ops.



**Table 19-14. Non-Architectural Performance Events for Intel Atom Processors**

Event Num.	Umask Value	Event Name	Definition	Description and Comment
CAH	01H	SIMD_COMP_INST_RETIREDPACKED_SINGLE	Retired computational Streaming SIMD Extensions (SSE) packed-single instructions.	This event counts the number of computational SSE packed-single instructions retired. Computational instructions perform arithmetic computations, like add, multiply and divide. Instructions that perform load and store operations or logical operations, like XOR, OR, and AND are not counted by this event.
CAH	02H	SIMD_COMP_INST_RETIREDSALAR_SINGLE	Retired computational Streaming SIMD Extensions (SSE) scalar-single instructions.	This event counts the number of computational SSE scalar-single instructions retired. Computational instructions perform arithmetic computations, like add, multiply and divide. Instructions that perform load and store operations or logical operations, like XOR, OR, and AND are not counted by this event.
CAH	04H	SIMD_COMP_INST_RETIREDPACKED_DOUBLE	Retired computational Streaming SIMD Extensions 2 (SSE2) packed-double instructions.	This event counts the number of computational SSE2 packed-double instructions retired. Computational instructions perform arithmetic computations, like add, multiply and divide. Instructions that perform load and store operations or logical operations, like XOR, OR, and AND are not counted by this event.
CAH	08H	SIMD_COMP_INST_RETIREDSALAR_DOUBLE	Retired computational Streaming SIMD Extensions 2 (SSE2) scalar-double instructions	This event counts the number of computational SSE2 scalar-double instructions retired. Computational instructions perform arithmetic computations, like add, multiply and divide. Instructions that perform load and store operations or logical operations, like XOR, OR, and AND are not counted by this event.
CBH	01H	MEM_LOAD_RETIRED.L2_HIT	Retired loads that hit the L2 cache (precise event)	This event counts the number of retired load operations that missed the L1 data cache and hit the L2 cache.
CBH	02H	MEM_LOAD_RETIRED.L2_MISS	Retired loads that miss the L2 cache (precise event)	This event counts the number of retired load operations that missed the L2 cache.

**Table 19-14. Non-Architectural Performance Events for Intel Atom Processors**

Event Num.	Umask Value	Event Name	Definition	Description and Comment
CBH	04H	MEM_LOAD_RETIRED.DTLB_MISSES	Retired loads that miss the DTLB (precise event)	This event counts the number of retired loads that missed the DTLB. The DTLB miss is not counted if the load operation causes a fault.
CDH	00H	SIMD_ASSIST	SIMD assists invoked	This event counts the number of SIMD assists invoked. SIMD assists are invoked when an EMMS instruction is executed after MMX™ technology code has changed the MMX state in the floating point stack. For example, these assists are required in the following cases: Streaming SIMD Extensions (SSE) instructions: 1. Denormal input when the DAZ (Denormals Are Zeros) flag is off 2. Underflow result when the FTZ (Flush To Zero) flag is off
CEH	00H	SIMD_INSTR_RETIRED	SIMD Instructions retired	This event counts the number of SIMD instructions that retired.
CFH	00H	SIMD_SATURATED_INSTR_RETIRED	Saturated arithmetic instructions retired	This event counts the number of saturated arithmetic SIMD instructions that retired.
EOH	01H	BR_INST_DECODED	Branch instructions decoded	This event counts the number of branch instructions decoded.

**Table 19-14. Non-Architectural Performance Events for Intel Atom Processors**

Event Num.	Umask Value	Event Name	Definition	Description and Comment
E4H	01H	BOGUS_BR	Bogus branches	This event counts the number of byte sequences that were mistakenly detected as taken branch instructions. This results in a BACLEAR event and the BTB is flushed. This occurs mainly after task switches.
E6H	01H	BACLEAR.S.ANY	BACLEAR asserted	This event counts the number of times the front end is redirected for a branch prediction, mainly when an early branch prediction is corrected by other branch handling mechanisms in the front-end. This can occur if the code has many branches such that they cannot be consumed by the branch predictor. Each Baclear asserted costs approximately 7 cycles. The effect on total execution time depends on the surrounding code.

## 19.9 PERFORMANCE MONITORING EVENTS FOR INTEL® CORE™ SOLO AND INTEL® CORE™ DUO PROCESSORS

Table 19-15 lists non-architectural performance events for Intel Core Duo processors. If a non-architectural event requires qualification in core specificity, it is indicated in the comment column. Table 19-15 also applies to Intel Core Solo processors; bits in the unit mask corresponding to core-specificity are reserved and should be 00B.

**Table 19-15. Non-Architectural Performance Events in Intel Core Solo and Intel Core Duo Processors**

Event Num.	Event Mask Mnemonic	Umask Value	Description	Comment
03H	LD_Blocks	00H	Load operations delayed due to store buffer blocks.  The preceding store may be blocked due to unknown address, unknown data, or conflict due to partial overlap between the load and store.	
04H	SD_Drains	00H	Cycles while draining store buffers.	

**Table 19-15. Non-Architectural Performance Events  
in Intel Core Solo and Intel Core Duo Processors (Contd.)**

Event Num.	Event Mask Mnemonic	Umask Value	Description	Comment
05H	Misalign_Mem_Ref	00H	Misaligned data memory references (MOB splits of loads and stores).	
06H	Seg_Reg_Loads	00H	Segment register loads.	
07H	SSE_PrefNta_Ret	00H	SSE software prefetch instruction PREFETCHNTA retired.	
07H	SSE_PrefT1_Ret	01H	SSE software prefetch instruction PREFETCHT1 retired.	
07H	SSE_PrefT2_Ret	02H	SSE software prefetch instruction PREFETCHT2 retired.	
07H	SSE_NTStores_Ret	03H	SSE streaming store instruction retired.	
10H	FP_Comps_Op_Exe	00H	FP computational Instruction executed. FADD, FSUB, FCOM, FMULs, MUL, IMUL, FDIVs, DIV, IDIV, FPREMs, FSQRT are included; but exclude FADD or FMUL used in the middle of a transcendental instruction.	
11H	FP_Assist	00H	FP exceptions experienced microcode assists.	IA32_PMC1 only.
12H	Mul	00H	Multiply operations (a speculative count, including FP and integer multiplies).	IA32_PMC1 only.
13H	Div	00H	Divide operations (a speculative count, including FP and integer divisions).	IA32_PMC1 only.
14H	Cycles_Div_Busy	00H	Cycles the divider is busy.	IA32_PMC0 only.
21H	L2_ADS	00H	L2 Address strobes.	Requires core-specificity
22H	Dbus_Busy	00H	Core cycle during which data bus was busy (increments by 4).	Requires core-specificity
23H	Dbus_Busy_Rd	00H	Cycles data bus is busy transferring data to a core (increments by 4).	Requires core-specificity

**Table 19-15. Non-Architectural Performance Events  
in Intel Core Solo and Intel Core Duo Processors (Contd.)**

Event Num.	Event Mask Mnemonic	Umask Value	Description	Comment
24H	L2_Lines_In	00H	L2 cache lines allocated.	Requires core-specificity and HW prefetch qualification
25H	L2_M_Lines_In	00H	L2 Modified-state cache lines allocated.	Requires core-specificity
26H	L2_Lines_Out	00H	L2 cache lines evicted.	Requires core-specificity and HW prefetch qualification
27H	L2_M_Lines_Out	00H	L2 Modified-state cache lines evicted.	
28H	L2_IFetch	Requires MESI qualification	L2 instruction fetches from instruction fetch unit (includes speculative fetches).	Requires core-specificity
29H	L2_LD	Requires MESI qualification	L2 cache reads.	Requires core-specificity
2AH	L2_ST	Requires MESI qualification	L2 cache writes (includes speculation).	Requires core-specificity
2EH	L2_Rqsts	Requires MESI qualification	L2 cache reference requests.	Requires core-specificity, HW prefetch qualification
30H	L2_Reject_Cycles	Requires MESI qualification	Cycles L2 is busy and rejecting new requests.	
32H	L2_No_Request_Cycles	Requires MESI qualification	Cycles there is no request to access L2.	
3AH	EST_Trans_All	00H	Any Intel Enhanced SpeedStep(R) Technology transitions.	
3AH	EST_Trans_All	10H	Intel Enhanced SpeedStep Technology frequency transitions.	
3BH	Thermal_Trip	COH	Duration in a thermal trip based on the current core clock.	Use edge trigger to count occurrence
3CH	NonHlt_Ref_Cycles	01H	Non-halted bus cycles.	

**Table 19-15. Non-Architectural Performance Events  
in Intel Core Solo and Intel Core Duo Processors (Contd.)**

Event Num.	Event Mask Mnemonic	Umask Value	Description	Comment
3CH	Serial_Execution_Cycles	02H	Non-halted bus cycles of this core executing code while the other core is halted.	
40H	DCache_Cache_LD	Requires MESI qualification	L1 cacheable data read operations.	
41H	DCache_Cache_ST	Requires MESI qualification	L1 cacheable data write operations.	
42H	DCache_Cache_Lock	Requires MESI qualification	L1 cacheable lock read operations to invalid state.	
43H	Data_Mem_Ref	01H	L1 data read and writes of cacheable and non-cacheable types.	
44H	Data_Mem_Cache_Ref	02H	L1 data cacheable read and write operations.	
45H	DCache_Repl	0FH	L1 data cache line replacements.	
46H	DCache_M_Repl	00H	L1 data M-state cache line allocated.	
47H	DCache_M_Evict	00H	L1 data M-state cache line evicted.	
48H	DCache_Pend_Miss	00H	Weighted cycles of L1 miss outstanding.	Use Cmask =1 to count duration.
49H	Dtlb_Miss	00H	Data references that missed TLB.	
4BH	SSE_PrefNta_Miss	00H	PREFETCHNTA missed all caches.	
4BH	SSE_PrefT1_Miss	01H	PREFETCHT1 missed all caches.	
4BH	SSE_PrefT2_Miss	02H	PREFETCHT2 missed all caches.	
4BH	SSE_NTStores_Miss	03H	SSE streaming store instruction missed all caches.	
4FH	L1_Pref_Req	00H	L1 prefetch requests due to DCU cache misses.	May overcount if request re-submitted

**Table 19-15. Non-Architectural Performance Events  
in Intel Core Solo and Intel Core Duo Processors (Contd.)**

Event Num.	Event Mask Mnemonic	Umask Value	Description	Comment
60H	Bus_Req_Outstanding	00; Requires core-specificity, and agent specificity	Weighted cycles of cacheable bus data read requests. This event counts full-line read request from DCU or HW prefetcher, but not RFO, write, instruction fetches, or others.	Use Cmask = 1 to count duration. Use Umask bit 12 to include HWP or exclude HWP separately.
61H	Bus_BNR_Clocks	00H	External bus cycles while BNR asserted.	
62H	Bus_DRDY_Clocks	00H	External bus cycles while DRDY asserted.	Requires agent specificity
63H	Bus_Locks_Clocks	00H	External bus cycles while bus lock signal asserted.	Requires core specificity
64H	Bus_Data_Rcv	40H	Number of data chunks received by this processor.	
65H	Bus_Trans_Brd	See comment.	Burst read bus transactions (data or code).	Requires core specificity
66H	Bus_Trans_RFO	See comment.	Completed read for ownership (RFO) transactions.	Requires agent specificity
68H	Bus_Trans_Ifetch	See comment.	Completed instruction fetch transactions.	Requires core specificity
69H	Bus_Trans_Inval	See comment.	Completed invalidate transactions.	Each transaction counts its address strobe Retried transaction may be counted more than once
6AH	Bus_Trans_Pwr	See comment.	Completed partial write transactions.	
6BH	Bus_Trans_P	See comment.	Completed partial transactions (include partial read + partial write + line write).	
6CH	Bus_Trans_IO	See comment.	Completed I/O transactions (read and write).	
6DH	Bus_Trans_Def	20H	Completed defer transactions.	Requires core specificity Retried transaction may be counted more than once

**Table 19-15. Non-Architectural Performance Events  
in Intel Core Solo and Intel Core Duo Processors (Contd.)**

Event Num.	Event Mask Mnemonic	Umask Value	Description	Comment
67H	Bus_Trans_WB	COH	Completed writeback transactions from DCU (does not include L2 writebacks).	Requires agent specificity Each transaction counts its address strobe Retried transaction may be counted more than once
6EH	Bus_Trans_Burst	COH	Completed burst transactions (full line transactions include reads, write, RFO, and writebacks).	
6FH	Bus_Trans_Mem	COH	Completed memory transactions. This includes Bus_Trans_Burst + Bus_Trans_P+Bus_Trans_Inval.	
70H	Bus_Trans_Any	COH	Any completed bus transactions.	
77H	Bus_Snoops	00H	Counts any snoop on the bus.	Requires MESI qualification Requires agent specificity
78H	DCU_Snoop_To_Share	01H	DCU snoops to share-state L1 cache line due to L1 misses.	Requires core specificity
7DH	Bus_Not_In_Use	00H	Number of cycles there is no transaction from the core.	Requires core specificity
7EH	Bus_Snoop_Stall	00H	Number of bus cycles while bus snoop is stalled.	
80H	ICache_Reads	00H	Number of instruction fetches from ICache, streaming buffers (both cacheable and uncacheable fetches).	
81H	ICache_Misses	00H	Number of instruction fetch misses from ICache, streaming buffers.	
85H	ITLB_Misses	00H	Number of iTLB misses.	
86H	IFU_Mem_Stall	00H	Cycles IFU is stalled while waiting for data from memory.	
87H	ILD_Stall	00H	Number of instruction length decoder stalls (Counts number of LCP stalls).	
88H	Br_Inst_Exec	00H	Branch instruction executed (includes speculation).	



**Table 19-15. Non-Architectural Performance Events  
in Intel Core Solo and Intel Core Duo Processors (Contd.)**

Event Num.	Event Mask Mnemonic	Umask Value	Description	Comment
89H	Br_Missp_Exec	00H	Branch instructions executed and mispredicted at execution (includes branches that do not have prediction or mispredicted).	
8AH	Br_BAC_Missp_Exec	00H	Branch instructions executed that were mispredicted at front end.	
8BH	Br_Cnd_Exec	00H	Conditional branch instructions executed.	
8CH	Br_Cnd_Missp_Exec	00H	Conditional branch instructions executed that were mispredicted.	
8DH	Br_Ind_Exec	00H	Indirect branch instructions executed.	
8EH	Br_Ind_Missp_Exec	00H	Indirect branch instructions executed that were mispredicted.	
8FH	Br_Ret_Exec	00H	Return branch instructions executed.	
90H	Br_Ret_Missp_Exec	00H	Return branch instructions executed that were mispredicted.	
91H	Br_Ret_BAC_Missp_Exec	00H	Return branch instructions executed that were mispredicted at the front end.	
92H	Br_Call_Exec	00H	Return call instructions executed.	
93H	Br_Call_Missp_Exec	00H	Return call instructions executed that were mispredicted.	
94H	Br_Ind_Call_Exec	00H	Indirect call branch instructions executed.	
A2H	Resource_Stall	00H	Cycles while there is a resource related stall (renaming, buffer entries) as seen by allocator.	
BOH	MMX_Instr_Exec	00H	Number of MMX instructions executed (does not include MOVQ and MOVD stores).	
B1H	SIMD_Int_Sat_Exec	00H	Number of SIMD Integer saturating instructions executed.	
B3H	SIMD_Int_Pmul_Exec	01H	Number of SIMD Integer packed multiply instructions executed.	

**Table 19-15. Non-Architectural Performance Events  
in Intel Core Solo and Intel Core Duo Processors (Contd.)**

Event Num.	Event Mask Mnemonic	Umask Value	Description	Comment
B3H	SIMD_Int_Psft_Exec	02H	Number of SIMD Integer packed shift instructions executed.	
B3H	SIMD_Int_Pck_Exec	04H	Number of SIMD Integer pack operations instruction executed.	
B3H	SIMD_Int_Upck_Exec	08H	Number of SIMD Integer unpack instructions executed.	
B3H	SIMD_Int_Plog_Exec	10H	Number of SIMD Integer packed logical instructions executed.	
B3H	SIMD_Int_Pari_Exec	20H	Number of SIMD Integer packed arithmetic instructions executed.	
C0H	Instr_Ret	00H	Number of instruction retired (Macro fused instruction count as 2).	
C1H	FP_Comp_Instr_Ret	00H	Number of FP compute instructions retired (X87 instruction or instruction that contain X87 operations).	Use IA32_PMC0 only.
C2H	Uops_Ret	00H	Number of micro-ops retired (include fused uops).	
C3H	SMC_Detected	00H	Number of times self-modifying code condition detected.	
C4H	Br_Instr_Ret	00H	Number of branch instructions retired.	
C5H	Br_MisPred_Ret	00H	Number of mispredicted branch instructions retired.	
C6H	Cycles_Int_Masked	00H	Cycles while interrupt is disabled.	
C7H	Cycles_Int_Pedning_Masked	00H	Cycles while interrupt is disabled and interrupts are pending.	
C8H	HW_Int_Rx	00H	Number of hardware interrupts received.	
C9H	Br_Taken_Ret	00H	Number of taken branch instruction retired.	
CAH	Br_MisPred_Taken_Ret	00H	Number of taken and mispredicted branch instructions retired.	
CCH	MMX_FP_Trans	00H	Number of transitions from MMX to X87.	

**Table 19-15. Non-Architectural Performance Events  
in Intel Core Solo and Intel Core Duo Processors (Contd.)**

Event Num.	Event Mask Mnemonic	Umask Value	Description	Comment
CCH	FP_MMX_Trans	01H	Number of transitions from X87 to MMX.	
CDH	MMX_Assist	00H	Number of EMMS executed.	
CEH	MMX_Instr_Ret	00H	Number of MMX instruction retired.	
DOH	Instr_Decoded	00H	Number of instruction decoded.	
D7H	ESP_Uops	00H	Number of ESP folding instruction decoded.	
D8H	SIMD_FP_SP_Ret	00H	Number of SSE/SSE2 single precision instructions retired (packed and scalar).	
D8H	SIMD_FP_SP_S_Ret	01H	Number of SSE/SSE2 scalar single precision instructions retired.	
D8H	SIMD_FP_DP_P_Ret	02H	Number of SSE/SSE2 packed double precision instructions retired.	
D8H	SIMD_FP_DP_S_Ret	03H	Number of SSE/SSE2 scalar double precision instructions retired.	
D8H	SIMD_Int_128_Ret	04H	Number of SSE2 128 bit integer instructions retired.	
D9H	SIMD_FP_SP_P_Comp_Ret	00H	Number of SSE/SSE2 packed single precision compute instructions retired (does not include AND, OR, XOR).	
D9H	SIMD_FP_SP_S_Comp_Ret	01H	Number of SSE/SSE2 scalar single precision compute instructions retired (does not include AND, OR, XOR).	
D9H	SIMD_FP_DP_P_Comp_Ret	02H	Number of SSE/SSE2 packed double precision compute instructions retired (does not include AND, OR, XOR).	
D9H	SIMD_FP_DP_S_Comp_Ret	03H	Number of SSE/SSE2 scalar double precision compute instructions retired (does not include AND, OR, XOR).	
DAH	Fused_Uops_Ret	00H	All fused uops retired.	

**Table 19-15. Non-Architectural Performance Events  
in Intel Core Solo and Intel Core Duo Processors (Contd.)**

Event Num.	Event Mask Mnemonic	Umask Value	Description	Comment
DAH	Fused_Ld_Uops_Ret	01H	Fused load uops retired.	
DAH	Fused_St_Uops_Ret	02H	Fused store uops retired.	
DBH	Unfusion	00H	Number of unfusion events in the ROB (due to exception).	
E0H	Br_Instr_Decoded	00H	Branch instructions decoded.	
E2H	BTB_Misses	00H	Number of branches the BTB did not produce a prediction.	
E4H	Br_Bogus	00H	Number of bogus branches.	
E6H	BAClears	00H	Number of BAClears asserted.	
F0H	Pref_Rqsts_Up	00H	Number of hardware prefetch requests issued in forward streams.	
F8H	Pref_Rqsts_Dn	00H	Number of hardware prefetch requests issued in backward streams.	

## 19.10 PENTIUM 4 AND INTEL XEON PROCESSOR PERFORMANCE-MONITORING EVENTS

Tables 19-16, 19-17 and list performance-monitoring events that can be counted or sampled on processors based on Intel NetBurst<sup>®</sup> microarchitecture. Table 19-16 lists the non-retirement events, and Table 19-17 lists the at-retirement events. Tables 19-19, 19-20, and 19-21 describes three sets of parameters that are available for three of the at-retirement counting events defined in Table 19-17. Table 19-22 shows which of the non-retirement and at retirement events are logical processor specific (TS) (see Section 18.11.4, "Performance Monitoring Events") and which are non-logical processor specific (TI).

Some of the Pentium 4 and Intel Xeon processor performance-monitoring events may be available only to specific models. The performance-monitoring events listed in Tables 19-16 and 19-17 apply to processors with CPUID signature that matches family encoding 15, model encoding 0, 1, 2 3, 4, or 6. Table applies to processors with a CPUID signature that matches family encoding 15, model encoding 3, 4 or 6.

The functionality of performance-monitoring events in Pentium 4 and Intel Xeon processors is also available when IA-32e mode is enabled.

**Table 19-16. Performance Monitoring Events Supported by Intel NetBurst Microarchitecture for Non-Retirement Counting**

Event Name	Event Parameters	Parameter Value	Description
TC_deliver_mode			This event counts the duration (in clock cycles) of the operating modes of the trace cache and decode engine in the processor package. The mode is specified by one or more of the event mask bits.
	ESCR restrictions	MSR_TC_ESCR0 MSR_TC_ESCR1	
	Counter numbers per ESCR	ESCR0: 4, 5 ESCR1: 6, 7	
	ESCR Event Select	01H	ESCR[31:25]
	ESCR Event Mask	Bit 0: DD 1: DB 2: DI 3: BD 4: BB 5: BI	ESCR[24:9]  Both logical processors are in deliver mode.  Logical processor 0 is in deliver mode and logical processor 1 is in build mode.  Logical processor 0 is in deliver mode and logical processor 1 is either halted, under a machine clear condition or transitioning to a long microcode flow.  Logical processor 0 is in build mode and logical processor 1 is in deliver mode.  Both logical processors are in build mode.  Logical processor 0 is in build mode and logical processor 1 is either halted, under a machine clear condition or transitioning to a long microcode flow.

**Table 19-16. Performance Monitoring Events Supported by Intel NetBurst Microarchitecture for Non-Retirement Counting (Contd.)**

Event Name	Event Parameters	Parameter Value	Description
		6: ID	Logical processor 0 is either halted, under a machine clear condition or transitioning to a long microcode flow. Logical processor 1 is in deliver mode.
		7: IB	Logical processor 0 is either halted, under a machine clear condition or transitioning to a long microcode flow. Logical processor 1 is in build mode.
	CCCR Select	01H	CCCR[15:13]
	Event Specific Notes		If only one logical processor is available from a physical processor package, the event mask should be interpreted as logical processor 1 is halted. Event mask bit 2 was previously known as "DELIVER", bit 5 was previously known as "BUILD".
BPU_fetch_request			This event counts instruction fetch requests of specified request type by the Branch Prediction unit. Specify one or more mask bits to qualify the request type(s).
	ESCR restrictions	MSR_BPU_ESCR0 MSR_BPU_ESCR1	
	Counter numbers per ESCR	ESCR0: 0, 1 ESCR1: 2, 3	
	ESCR Event Select	03H	ESCR[31:25]
	ESCR Event Mask	Bit 0: TCMISS	ESCR[24:9] Trace cache lookup miss
	CCCR Select	00H	CCCR[15:13]
ITLB_reference			This event counts translations using the Instruction Translation Look-aside Buffer (ITLB).

**Table 19-16. Performance Monitoring Events Supported by Intel NetBurst Microarchitecture for Non-Retirement Counting (Contd.)**

Event Name	Event Parameters	Parameter Value	Description
	ESCR restrictions	MSR_ITLB_ESCRO MSR_ITLB_ESCR1	
	Counter numbers per ESCR	ESCRO: 0, 1 ESCR1: 2, 3	
	ESCR Event Select	18H	ESCR[31:25]
	ESCR Event Mask	Bit 0: HIT 1: MISS 2: HIT_UC	ESCR[24:9]  ITLB hit ITLB miss Uncacheable ITLB hit
	CCCR Select	03H	CCCR[15:13]
	Event Specific Notes		All page references regardless of the page size are looked up as actual 4-KByte pages. Use the page_walk_type event with the ITMISS mask for a more conservative count.
memory_cancel			This event counts the canceling of various type of request in the Data cache Address Control unit (DAC). Specify one or more mask bits to select the type of requests that are canceled.
	ESCR restrictions	MSR_DAC_ESCRO MSR_DAC_ESCR1	
	Counter numbers per ESCR	ESCRO: 8, 9 ESCR1: 10, 11	
	ESCR Event Select	02H	ESCR[31:25]
	ESCR Event Mask	Bit 2: ST_RB_FULL 3: 64K_CONF	ESCR[24:9]  Replayed because no store request buffer is available Conflicts due to 64-KByte aliasing
	CCCR Select	05H	CCCR[15:13]

**Table 19-16. Performance Monitoring Events Supported by Intel NetBurst Microarchitecture for Non-Retirement Counting (Contd.)**

Event Name	Event Parameters	Parameter Value	Description
	Event Specific Notes		All_CACHE_MISS includes uncacheable memory in count.
memory_complete			This event counts the completion of a load split, store split, uncacheable (UC) split, or UC load. Specify one or more mask bits to select the operations to be counted.
	ESCR restrictions	MSR_SAAT_ESCR0 MSR_SAAT_ESCR1	
	Counter numbers per ESCR	ESCR0: 8, 9 ESCR1: 10, 11	
	ESCR Event Select	08H	ESCR[31:25]
	ESCR Event Mask	Bit 0: LSC  1: SSC	ESCR[24:9]  Load split completed, excluding UC/WC loads  Any split stores completed
	CCCR Select	02H	CCCR[15:13]
load_port_replay			This event counts replayed events at the load port. Specify one or more mask bits to select the cause of the replay.
	ESCR restrictions	MSR_SAAT_ESCR0 MSR_SAAT_ESCR1	
	Counter numbers per ESCR	ESCR0: 8, 9 ESCR1: 10, 11	
	ESCR Event Select	04H	ESCR[31:25]
	ESCR Event Mask	Bit 1: SPLIT_LD	ESCR[24:9] Split load.
	CCCR Select	02H	CCCR[15:13]
	Event Specific Notes		Must use ESCR1 for at-retirement counting.



**Table 19-16. Performance Monitoring Events Supported by Intel NetBurst Microarchitecture for Non-Retirement Counting (Contd.)**

Event Name	Event Parameters	Parameter Value	Description
store_port_replay			This event counts replayed events at the store port. Specify one or more mask bits to select the cause of the replay.
	ESCR restrictions	MSR_SAAT_ESCR0 MSR_SAAT_ESCR1	
	Counter numbers per ESCR	ESCR0: 8, 9 ESCR1: 10, 11	
	ESCR Event Select	05H	ESCR[31:25]
	ESCR Event Mask	Bit 1: SPLIT_ST	ESCR[24:9] Split store
	CCCR Select	02H	CCCR[15:13]
	Event Specific Notes		Must use ESCR1 for at-retirement counting.
MOB_load_replay			This event triggers if the memory order buffer (MOB) caused a load operation to be replayed. Specify one or more mask bits to select the cause of the replay.
	ESCR restrictions	MSR_MOB_ESCR0 MSR_MOB_ESCR1	
	Counter numbers per ESCR	ESCR0: 0, 1 ESCR1: 2, 3	
	ESCR Event Select	03H	ESCR[31:25]
	ESCR Event Mask	Bit 1: NO_STA  3: NO_STD	ESCR[24:9]  Replayed because of unknown store address.  Replayed because of unknown store data.

**Table 19-16. Performance Monitoring Events Supported by Intel NetBurst Microarchitecture for Non-Retirement Counting (Contd.)**

Event Name	Event Parameters	Parameter Value	Description
		4: PARTIAL_DATA  5: UNALGN_ADDR	Replayed because of partially overlapped data access between the load and store operations.  Replayed because the lower 4 bits of the linear address do not match between the load and store operations.
	CCCR Select	02H	CCCR[15:13]
page_walk_type			This event counts various types of page walks that the page miss handler (PMH) performs.
	ESCR restrictions	MSR_PMH_ESCR0 MSR_PMH_ESCR1	
	Counter numbers per ESCR	ESCR0: 0, 1 ESCR1: 2, 3	
	ESCR Event Select	01H	ESCR[31:25]
	ESCR Event Mask	Bit 0: DTMISS  1: ITMISS	ESCR[24:9]  Page walk for a data TLB miss (either load or store).  Page walk for an instruction TLB miss.
	CCCR Select	04H	CCCR[15:13]
BSQ_cache_reference			This event counts cache references (2nd level cache or 3rd level cache) as seen by the bus unit.  Specify one or more mask bit to select an access according to the access type (read type includes both load and RFO, write type includes writebacks and evictions) and the access result (hit, misses).

**Table 19-16. Performance Monitoring Events Supported by Intel NetBurst Microarchitecture for Non-Retirement Counting (Contd.)**

Event Name	Event Parameters	Parameter Value	Description
	ESCR restrictions	MSR_BSU_ESCR0 MSR_BSU_ESCR1	
	Counter numbers per ESCR	ESCR0: 0, 1 ESCR1: 2, 3	
	ESCR Event Select	0CH	ESCR[31:25]
		Bit 0: RD_2ndL_HITS 1: RD_2ndL_HITE 2: RD_2ndL_HITM 3: RD_3rdL_HITS 4: RD_3rdL_HITE 5: RD_3rdL_HITM	ESCR[24:9]  Read 2nd level cache hit Shared (includes load and RFO) Read 2nd level cache hit Exclusive (includes load and RFO) Read 2nd level cache hit Modified (includes load and RFO) Read 3rd level cache hit Shared (includes load and RFO) Read 3rd level cache hit Exclusive (includes load and RFO) Read 3rd level cache hit Modified (includes load and RFO)
	ESCR Event Mask	8: RD_2ndL_MISS 9: RD_3rdL_MISS 10: WR_2ndL_MISS	Read 2nd level cache miss (includes load and RFO) Read 3rd level cache miss (includes load and RFO) A Writeback lookup from DAC misses the 2nd level cache (unlikely to happen)
	CCCR Select	07H	CCCR[15:13]
	Event Specific Notes		1: The implementation of this event in current Pentium 4 and Xeon processors treats either a load operation or a request for ownership (RFO) request as a "read" type operation.

**Table 19-16. Performance Monitoring Events Supported by Intel NetBurst Microarchitecture for Non-Retirement Counting (Contd.)**

Event Name	Event Parameters	Parameter Value	Description
			<p>2: Currently this event causes both over and undercounting by as much as a factor of two due to an erratum.</p> <p>3: It is possible for a transaction that is started as a prefetch to change the transaction's internal status, making it no longer a prefetch. or change the access result status (hit, miss) as seen by this event.</p>
IOQ_allocation			<p>This event counts the various types of transactions on the bus. A count is generated each time a transaction is allocated into the IOQ that matches the specified mask bits. An allocated entry can be a sector (64 bytes) or a chunks of 8 bytes.</p>
			<p>Requests are counted once per retry. The event mask bits constitute 4 bit fields. A transaction type is specified by interpreting the values of each bit field.</p> <p>Specify one or more event mask bits in a bit field to select the value of the bit field.</p> <p>Each field (bits 0-4 are one field) are independent of and can be ORed with the others. The request type field is further combined with bit 5 and 6 to form a binary expression. Bits 7 and 8 form a bit field to specify the memory type of the target address.</p>

**Table 19-16. Performance Monitoring Events Supported by Intel NetBurst Microarchitecture for Non-Retirement Counting (Contd.)**

Event Name	Event Parameters	Parameter Value	Description
			Bits 13 and 14 form a bit field to specify the source agent of the request. Bit 15 affects read operation only. The event is triggered by evaluating the logical expression: (((Request type) OR Bit 5 OR Bit 6) OR (Memory type)) AND (Source agent).
	ESCR restrictions	MSR_FSB_ESCR0, MSR_FSB_ESCR1	
	Counter numbers per ESCR	ESCR0: 0, 1; ESCR1: 2, 3	
	ESCR Event Select	03H	ESCR[31:25]
	ESCR Event Mask	Bits 0-4 (single field)  5: ALL_READ 6: ALL_WRITE 7: MEM_UC 8: MEM_WC 9: MEM_WT  10: MEM_WP  11: MEM_WB 13: OWN  14: OTHER  15: PREFETCH	ESCR[24:9]  Bus request type (use 00001 for invalid or default) Count read entries Count write entries Count UC memory access entries Count WC memory access entries Count write-through (WT) memory access entries. Count write-protected (WP) memory access entries Count WB memory access entries. Count all store requests driven by processor, as opposed to other processor or DMA. Count all requests driven by other processors or DMA. Include HW and SW prefetch requests in the count.
	CCCR Select	06H	CCCR[15:13]

**Table 19-16. Performance Monitoring Events Supported by Intel NetBurst Microarchitecture for Non-Retirement Counting (Contd.)**

Event Name	Event Parameters	Parameter Value	Description
	Event Specific Notes		<p>1: If PREFETCH bit is cleared, sectors fetched using prefetch are excluded in the counts. If PREFETCH bit is set, all sectors or chunks read are counted.</p> <p>2: Specify the edge trigger in CCCR to avoid double counting.</p> <p>3: The mapping of interpreted bit field values to transaction types may differ with different processor model implementations of the Pentium 4 processor family. Applications that program performance monitoring events should use CPUID to determine processor models when using this event. The logic equations that trigger the event are model-specific (see 4a and 4b below).</p> <p>4a: For Pentium 4 and Xeon Processors starting with CPUID Model field encoding equal to 2 or greater, this event is triggered by evaluating the logical expression ((Request type) and (Bit 5 or Bit 6) and (Memory type) and (Source agent)).</p>

**Table 19-16. Performance Monitoring Events Supported by Intel NetBurst Microarchitecture for Non-Retirement Counting (Contd.)**

Event Name	Event Parameters	Parameter Value	Description
			<p>4b: For Pentium 4 and Xeon Processors with CPUID Model field encoding less than 2, this event is triggered by evaluating the logical expression [((Request type) or Bit 5 or Bit 6) or (Memory type)] and (Source agent). Note that event mask bits for memory type are ignored if either ALL_READ or ALL_WRITE is specified.</p> <p>5: This event is known to ignore CPL in early implementations of Pentium 4 and Xeon Processors. Both user requests and OS requests are included in the count. This behavior is fixed starting with Pentium 4 and Xeon Processors with CPUID signature 0xF27 (Family 15, Model 2, Stepping 7).</p> <p>6: For write-through (WT) and write-protected (WP) memory types, this event counts reads as the number of 64-byte sectors. Writes are counted by individual chunks.</p> <p>7: For uncacheable (UC) memory types, this event counts the number of 8-byte chunks allocated.</p> <p>8: For Pentium 4 and Xeon Processors with CPUID Signature less than 0xf27, only MSR_FSB_ESCR0 is available.</p>

**Table 19-16. Performance Monitoring Events Supported by Intel NetBurst Microarchitecture for Non-Retirement Counting (Contd.)**

Event Name	Event Parameters	Parameter Value	Description	
IOQ_active_entries			<p>This event counts the number of entries (clipped at 15) in the IOQ that are active. An allocated entry can be a sector (64 bytes) or a chunks of 8 bytes.</p> <p>The event must be programmed in conjunction with IOQ_allocation. Specify one or more event mask bits to select the transactions that is counted.</p>	
	ESCR restrictions	MSR_FSB_ESCR1		
	Counter numbers per ESCR	ESCR1: 2, 3		
	ESCR Event Select	01AH	ESCR[30:25]	
	ESCR Event Mask	Bits 0-4 (single field)  5: ALL_READ 6: ALL_WRITE 7: MEM_UC 8: MEM_WC 9: MEM_WT  10: MEM_WP  11: MEM_WB 13: OWN		ESCR[24:9]  Bus request type (use 00001 for invalid or default). Count read entries. Count write entries. Count UC memory access entries. Count WC memory access entries. Count write-through (WT) memory access entries. Count write-protected (WP) memory access entries. Count WB memory access entries. Count all store requests driven by processor, as opposed to other processor or DMA.
		14: OTHER  15: PREFETCH		Count all requests driven by other processors or DMA. Include HW and SW prefetch requests in the count.
CCCR Select	06H	CCCR[15:13]		



**Table 19-16. Performance Monitoring Events Supported by Intel NetBurst Microarchitecture for Non-Retirement Counting (Contd.)**

Event Name	Event Parameters	Parameter Value	Description
	Event Specific Notes		<p>1: Specified desired mask bits in ESCRO and ESCR1.</p> <p>2: See the ioq_allocation event for descriptions of the mask bits.</p> <p>3: Edge triggering should not be used when counting cycles.</p> <p>4: The mapping of interpreted bit field values to transaction types may differ across different processor model implementations of the Pentium 4 processor family. Applications that programs performance monitoring events should use the CPUID instruction to detect processor models when using this event. The logical expression that triggers this event as describe below:</p> <p>5a:For Pentium 4 and Xeon Processors starting with CPUID MODEL field encoding equal to 2 or greater, this event is triggered by evaluating the logical expression ((Request type) and (Bit 5 or Bit 6) and (Memory type) and (Source agent)).</p>

**Table 19-16. Performance Monitoring Events Supported by Intel NetBurst Microarchitecture for Non-Retirement Counting (Contd.)**

Event Name	Event Parameters	Parameter Value	Description
			<p>5b: For Pentium 4 and Xeon Processors starting with CPUID MODEL field encoding less than 2, this event is triggered by evaluating the logical expression <math>(((\text{Request type}) \text{ or Bit 5 or Bit 6}) \text{ or } (\text{Memory type})) \text{ and } (\text{Source agent})</math>. Event mask bits for memory type are ignored if either ALL_READ or ALL_WRITE is specified.</p> <p>5c: This event is known to ignore CPL in the current implementations of Pentium 4 and Xeon Processors Both user requests and OS requests are included in the count.</p> <p>6: An allocated entry can be a full line (64 bytes) or in individual chunks of 8 bytes.</p>
FSB_data_activity			This event increments once for each DRDY or DBSY event that occurs on the front side bus. The event allows selection of a specific DRDY or DBSY event.
	ESCR restrictions	MSR_FSB_ESCR0 MSR_FSB_ESCR1	
	Counter numbers per ESCR	ESCR0: 0, 1 ESCR1: 2, 3	
	ESCR Event Select	17H	ESCR[31:25]
	ESCR Event Mask	Bit 0: DRDY_DRV	ESCR[24:9]  Count when this processor drives data onto the bus - includes writes and implicit writebacks.

**Table 19-16. Performance Monitoring Events Supported by Intel NetBurst Microarchitecture for Non-Retirement Counting (Contd.)**

Event Name	Event Parameters	Parameter Value	Description
		1: DRDY_OWN	<p>Asserted two processor clock cycles for partial writes and 4 processor clocks (usually in consecutive bus clocks) for full line writes.</p> <p>Count when this processor reads data from the bus - includes loads and some PIC transactions. Asserted two processor clock cycles for partial reads and 4 processor clocks (usually in consecutive bus clocks) for full line reads.</p> <p>Count DRDY events that we drive. Count DRDY events sampled that we own.</p>
		2: DRDY_OTHER	<p>Count when data is on the bus but not being sampled by the processor. It may or may not be being driven by this processor.</p> <p>Asserted two processor clock cycles for partial transactions and 4 processor clocks (usually in consecutive bus clocks) for full line transactions.</p>
		3: DBSY_DRV	<p>Count when this processor reserves the bus for use in the next bus cycle in order to drive data. Asserted for two processor clock cycles for full line writes and not at all for partial line writes.</p> <p>May be asserted multiple times (in consecutive bus clocks) if we stall the bus waiting for a cache lock to complete.</p>

**Table 19-16. Performance Monitoring Events Supported by Intel NetBurst Microarchitecture for Non-Retirement Counting (Contd.)**

Event Name	Event Parameters	Parameter Value	Description
		4: DBSY_OWN	Count when some agent reserves the bus for use in the next bus cycle to drive data that this processor will sample.  Asserted for two processor clock cycles for full line writes and not at all for partial line writes. May be asserted multiple times (all one bus clock apart) if we stall the bus for some reason.
		5:DBSY_OTHER	Count when some agent reserves the bus for use in the next bus cycle to drive data that this processor will NOT sample. It may or may not be being driven by this processor.  Asserted two processor clock cycles for partial transactions and 4 processor clocks (usually in consecutive bus clocks) for full line transactions.
	CCCR Select	06H	CCCR[15:13]
	Event Specific Notes		Specify edge trigger in the CCCR MSR to avoid double counting.  DRDY_OWN and DRDY_OTHER are mutually exclusive; similarly for DBSY_OWN and DBSY_OTHER.
BSQ_allocation			This event counts allocations in the Bus Sequence Unit (BSQ) according to the specified mask bit encoding. The event mask bits consist of four sub-groups: <ul style="list-style-type: none"> <li>▪ request type,</li> <li>▪ request length</li> <li>▪ memory type</li> <li>▪ and sub-group consisting mostly of independent bits (bits 5, 6, 7, 8, 9, and 10)</li> </ul> Specify an encoding for each sub-group.

**Table 19-16. Performance Monitoring Events Supported by Intel NetBurst Microarchitecture for Non-Retirement Counting (Contd.)**

Event Name	Event Parameters	Parameter Value	Description
	ESCR restrictions	MSR_BSU_ESCR0	
	Counter numbers per ESCR	ESCR0: 0, 1	
	ESCR Event Select	05H	ESCR[31:25]
	ESCR Event Mask	Bit 0: REQ_TYPE0 1: REQ_TYPE1  2: REQ_LEN0 3: REQ_LEN1  5: REQ_IO_TYPE 6: REQ_LOCK_TYPE 7: REQ_CACHE_TYPE 8: REQ_SPLIT_TYPE 9: REQ_DEM_TYPE  10: REQ_ORD_TYPE	ESCR[24:9] Request type encoding (bit 0 and 1) are: 0 – Read (excludes read invalidate) 1 – Read invalidate 2 – Write (other than writebacks) 3 – Writeback (evicted from cache). (public)  Request length encoding (bit 2, 3) are: 0 – 0 chunks 1 – 1 chunks 3 – 8 chunks  Request type is input or output. Request type is bus lock.  Request type is cacheable.  Request type is a bus 8-byte chunk split across 8-byte boundary.  Request type is a demand if set. Request type is HW.SW prefetch if 0.  Request is an ordered type.

**Table 19-16. Performance Monitoring Events Supported by Intel NetBurst Microarchitecture for Non-Retirement Counting (Contd.)**

Event Name	Event Parameters	Parameter Value	Description
		11: MEM_TYPE0 12: MEM_TYPE1 13: MEM_TYPE2	Memory type encodings (bit 11-13) are: 0 - UC 1 - WC 4 - WT 5 - WP 6 - WB
	CCCR Select	07H	CCCR[15:13]
	Event Specific Notes		<ol style="list-style-type: none"> <li>1: Specify edge trigger in CCCR to avoid double counting.</li> <li>2: A writebacks to 3rd level cache from 2nd level cache counts as a separate entry, this is in additional to the entry allocated for a request to the bus.</li> <li>3: A read request to WB memory type results in a request to the 64-byte sector, containing the target address, followed by a prefetch request to an adjacent sector.</li> <li>4: For Pentium 4 and Xeon processors with CPUID model encoding value equals to 0 and 1, an allocated BSQ entry includes both the demand sector and prefetched 2nd sector.</li> <li>5: An allocated BSQ entry for a data chunk is any request less than 64 bytes.</li> <li>6a: This event may undercount for requests of split type transactions if the data address straddled across modulo-64 byte boundary.</li> </ol>

**Table 19-16. Performance Monitoring Events Supported by Intel NetBurst Microarchitecture for Non-Retirement Counting (Contd.)**

Event Name	Event Parameters	Parameter Value	Description
			<p>6b: This event may undercount for requests of read request of 16-byte operands from WC or UC address.</p> <p>6c: This event may undercount WC partial requests originated from store operands that are dwords.</p>
bsq_active_entries			<p>This event represents the number of BSQ entries (clipped at 15) currently active (valid) which meet the subevent mask criteria during allocation in the BSQ. Active request entries are allocated on the BSQ until de-allocated.</p> <p>De-allocation of an entry does not necessarily imply the request is filled. This event must be programmed in conjunction with BSQ_allocation. Specify one or more event mask bits to select the transactions that is counted.</p>
	ESCR restrictions	ESCR1	
	Counter numbers per ESCR	ESCR1: 2, 3	
	ESCR Event Select	06H	ESCR[30:25]
	ESCR Event Mask		ESCR[24:9]
	CCCR Select	07H	CCCR[15:13]
	Event Specific Notes		<ol style="list-style-type: none"> <li>1: Specified desired mask bits in ESCR0 and ESCR1.</li> <li>2: See the BSQ_allocation event for descriptions of the mask bits.</li> <li>3: Edge triggering should not be used when counting cycles.</li> </ol>

**Table 19-16. Performance Monitoring Events Supported by Intel NetBurst Microarchitecture for Non-Retirement Counting (Contd.)**

Event Name	Event Parameters	Parameter Value	Description
			<p>4: This event can be used to estimate the latency of a transaction from allocation to de-allocation in the BSQ. The latency observed by BSQ_allocation includes the latency of FSB, plus additional overhead.</p> <p>5: Additional overhead may include the time it takes to issue two requests (the sector by demand and the adjacent sector via prefetch). Since adjacent sector prefetches have lower priority than demand fetches, on a heavily used system there is a high probability that the adjacent sector prefetch will have to wait until the next bus arbitration.</p> <p>6: For Pentium 4 and Xeon processors with CPUID model encoding value less than 3, this event is updated every clock.</p> <p>7: For Pentium 4 and Xeon processors with CPUID model encoding value equals to 3 or 4, this event is updated every other clock.</p>
SSE_input_assist			<p>This event counts the number of times an assist is requested to handle problems with input operands for SSE/SSE2/SSE3 operations; most notably denormal source operands when the DAZ bit is not set. Set bit 15 of the event mask to use this event.</p>



**Table 19-16. Performance Monitoring Events Supported by Intel NetBurst Microarchitecture for Non-Retirement Counting (Contd.)**

Event Name	Event Parameters	Parameter Value	Description
	ESCR restrictions	MSR_FIRM_ESCR0 MSR_FIRM_ESCR1	
	Counter numbers per ESCR	ESCR0: 8, 9 ESCR1: 10, 11	
	ESCR Event Select	34H	ESCR[31:25]
	ESCR Event Mask	15: ALL	ESCR[24:9] Count assists for SSE/SSE2/SSE3 $\mu$ ops.
	CCCR Select	01H	CCCR[15:13]
	Event Specific Notes		1: Not all requests for assists are actually taken. This event is known to overcount in that it counts requests for assists from instructions on the non-retired path that do not incur a performance penalty. An assist is actually taken only for non-bogus $\mu$ ops. Any appreciable counts for this event are an indication that the DAZ or FTZ bit should be set and/or the source code should be changed to eliminate the condition.
			2: Two common situations for an SSE/SSE2/SSE3 operation needing an assist are: (1) when a denormal constant is used as an input and the Denormals-Are-Zero (DAZ) mode is not set, (2) when the input operand uses the underflowed result of a previous SSE/SSE2/SSE3 operation and neither the DAZ nor Flush-To-Zero (FTZ) modes are set.

**Table 19-16. Performance Monitoring Events Supported by Intel NetBurst Microarchitecture for Non-Retirement Counting (Contd.)**

Event Name	Event Parameters	Parameter Value	Description
			3: Enabling the DAZ mode prevents SSE/SSE2/SSE3 operations from needing assists in the first situation. Enabling the FTZ mode prevents SSE/SSE2/SSE3 operations from needing assists in the second situation.
packed_SP_uop			This event increments for each packed single-precision $\mu$ op, specified through the event mask for detection.
	ESCR restrictions	MSR_FIRM_ESCR0 MSR_FIRM_ESCR1	
	Counter numbers per ESCR	ESCR0: 8, 9 ESCR1: 10, 11	
	ESCR Event Select	08H	ESCR[31:25]
	ESCR Event Mask	Bit 15: ALL	ESCR[24:9] Count all $\mu$ ops operating on packed single-precision operands.
	CCCR Select	01H	CCCR[15:13]
	Event Specific Notes		1: If an instruction contains more than one packed SP $\mu$ ops, each packed SP $\mu$ op that is specified by the event mask will be counted. 2: This metric counts instances of packed memory $\mu$ ops in a repeat move string.
packed_DP_uop			This event increments for each packed double-precision $\mu$ op, specified through the event mask for detection.
	ESCR restrictions	MSR_FIRM_ESCR0 MSR_FIRM_ESCR1	

**Table 19-16. Performance Monitoring Events Supported by Intel NetBurst Microarchitecture for Non-Retirement Counting (Contd.)**

Event Name	Event Parameters	Parameter Value	Description
	Counter numbers per ESCR	ESCR0: 8, 9 ESCR1: 10, 11	
	ESCR Event Select	0CH	ESCR[31:25]
	ESCR Event Mask	Bit 15: ALL	ESCR[24:9] Count all $\mu$ ops operating on packed double-precision operands.
	CCCR Select	01H	CCCR[15:13]
	Event Specific Notes		If an instruction contains more than one packed DP $\mu$ ops, each packed DP $\mu$ op that is specified by the event mask will be counted.
scalar_SP_uop			This event increments for each scalar single-precision $\mu$ op, specified through the event mask for detection.
	ESCR restrictions	MSR_FIRM_ESCR0 MSR_FIRM_ESCR1	
	Counter numbers per ESCR	ESCR0: 8, 9 ESCR1: 10, 11	
	ESCR Event Select	0AH	ESCR[31:25]
	ESCR Event Mask	Bit 15: ALL	ESCR[24:9] Count all $\mu$ ops operating on scalar single-precision operands.
	CCCR Select	01H	CCCR[15:13]
	Event Specific Notes		If an instruction contains more than one scalar SP $\mu$ ops, each scalar SP $\mu$ op that is specified by the event mask will be counted.
scalar_DP_uop			This event increments for each scalar double-precision $\mu$ op, specified through the event mask for detection.
	ESCR restrictions	MSR_FIRM_ESCR0 MSR_FIRM_ESCR1	

**Table 19-16. Performance Monitoring Events Supported by Intel NetBurst Microarchitecture for Non-Retirement Counting (Contd.)**

Event Name	Event Parameters	Parameter Value	Description
	Counter numbers per ESCR	ESCR0: 8, 9 ESCR1: 10, 11	
	ESCR Event Select	0EH	ESCR[31:25]
	ESCR Event Mask	Bit 15: ALL	ESCR[24:9] Count all $\mu$ ops operating on scalar double-precision operands.
	CCCR Select	01H	CCCR[15:13]
	Event Specific Notes		If an instruction contains more than one scalar DP $\mu$ ops, each scalar DP $\mu$ op that is specified by the event mask is counted.
64bit_MMX_uop			This event increments for each MMX instruction, which operate on 64-bit SIMD operands.
	ESCR restrictions	MSR_FIRM_ESCR0 MSR_FIRM_ESCR1	
	Counter numbers per ESCR	ESCR0: 8, 9 ESCR1: 10, 11	
	ESCR Event Select	02H	ESCR[31:25]
	ESCR Event Mask	Bit 15: ALL	ESCR[24:9] Count all $\mu$ ops operating on 64-bit SIMD integer operands in memory or MMX registers.
	CCCR Select	01H	CCCR[15:13]
	Event Specific Notes		If an instruction contains more than one 64-bit MMX $\mu$ ops, each 64-bit MMX $\mu$ op that is specified by the event mask will be counted.
128bit_MMX_uop			This event increments for each integer SIMD SSE2 instruction, which operate on 128-bit SIMD operands.

**Table 19-16. Performance Monitoring Events Supported by Intel NetBurst Microarchitecture for Non-Retirement Counting (Contd.)**

Event Name	Event Parameters	Parameter Value	Description
	ESCR restrictions	MSR_FIRM_ESCR0 MSR_FIRM_ESCR1	
	Counter numbers per ESCR	ESCR0: 8, 9 ESCR1: 10, 11	
	ESCR Event Select	1AH	ESCR[31:25]
	ESCR Event Mask	Bit 15: ALL	ESCR[24:9] Count all $\mu$ ops operating on 128-bit SIMD integer operands in memory or XMM registers.
	CCCR Select	01H	CCCR[15:13]
	Event Specific Notes		If an instruction contains more than one 128-bit MMX $\mu$ ops, each 128-bit MMX $\mu$ op that is specified by the event mask will be counted.
x87_FP_uop			This event increments for each x87 floating-point $\mu$ op, specified through the event mask for detection.
	ESCR restrictions	MSR_FIRM_ESCR0 MSR_FIRM_ESCR1	
	Counter numbers per ESCR	ESCR0: 8, 9 ESCR1: 10, 11	
	ESCR Event Select	04H	ESCR[31:25]
	ESCR Event Mask	Bit 15: ALL	ESCR[24:9] Count all x87 FP $\mu$ ops.
	CCCR Select	01H	CCCR[15:13]
	Event Specific Notes		1: If an instruction contains more than one x87 FP $\mu$ ops, each x87 FP $\mu$ op that is specified by the event mask will be counted. 2: This event does not count x87 FP $\mu$ op for load, store, move between registers.

**Table 19-16. Performance Monitoring Events Supported by Intel NetBurst Microarchitecture for Non-Retirement Counting (Contd.)**

Event Name	Event Parameters	Parameter Value	Description
TC_misc			This event counts miscellaneous events detected by the TC. The counter will count twice for each occurrence.
	ESCR restrictions	MSR_TC_ESCR0 MSR_TC_ESCR1	
	Counter numbers per ESCR	ESCR0: 4, 5 ESCR1: 6, 7	
	ESCR Event Select	06H	ESCR[31:25]
	CCCR Select	01H	CCCR[15:13]
	ESCR Event Mask	Bit 4: FLUSH	ESCR[24:9] Number of flushes
global_power_events			This event accumulates the time during which a processor is not stopped.
	ESCR restrictions	MSR_FSB_ESCR0 MSR_FSB_ESCR1	
	Counter numbers per ESCR	ESCR0: 0, 1 ESCR1: 2, 3	
	ESCR Event Select	013H	ESCR[31:25]
	ESCR Event Mask	Bit 0: Running	ESCR[24:9] The processor is active (includes the handling of HLT STPCLK and throttling.
	CCCR Select	06H	CCCR[15:13]
tc_ms_xfer			This event counts the number of times that uop delivery changed from TC to MS ROM.
	ESCR restrictions	MSR_MS_ESCR0 MSR_MS_ESCR1	
	Counter numbers per ESCR	ESCR0: 4, 5 ESCR1: 6, 7	
	ESCR Event Select	05H	ESCR[31:25]

**Table 19-16. Performance Monitoring Events Supported by Intel NetBurst Microarchitecture for Non-Retirement Counting (Contd.)**

Event Name	Event Parameters	Parameter Value	Description
	ESCR Event Mask	Bit 0: CISC	ESCR[24:9] A TC to MS transfer occurred.
	CCCR Select	0H	CCCR[15:13]
uop_queue_writes			This event counts the number of valid uops written to the uop queue. Specify one or more mask bits to select the source type of writes.
	ESCR restrictions	MSR_MS_ESCR0 MSR_MS_ESCR1	
	Counter numbers per ESCR	ESCR0: 4, 5 ESCR1: 6, 7	
	ESCR Event Select	09H	ESCR[31:25]
	ESCR Event Mask	Bit 0: FROM_TC_BUILD 1: FROM_TC_DELIVER 2: FROM_ROM	ESCR[24:9]  The uops being written are from TC build mode.  The uops being written are from TC deliver mode.  The uops being written are from microcode ROM.
	CCCR Select	0H	CCCR[15:13]
retired_mispred_branch_type			This event counts retiring mispredicted branches by type.
	ESCR restrictions	MSR_TBPU_ESCR0 MSR_TBPU_ESCR1	
	Counter numbers per ESCR	ESCR0: 4, 5 ESCR1: 6, 7	
	ESCR Event Select	05H	ESCR[30:25]
	ESCR Event Mask	Bit 1: CONDITIONAL 2: CALL	ESCR[24:9]  Conditional jumps. Indirect call branches.

**Table 19-16. Performance Monitoring Events Supported by Intel NetBurst Microarchitecture for Non-Retirement Counting (Contd.)**

Event Name	Event Parameters	Parameter Value	Description
		3: RETURN 4: INDIRECT	Return branches. Returns, indirect calls, or indirect jumps.
	CCCR Select	02H	CCCR[15:13]
	Event Specific Notes		This event may overcount conditional branches if: <ul style="list-style-type: none"> <li>▪ Mispredictions cause the trace cache and delivery engine to build new traces.</li> <li>▪ When the processor’s pipeline is being cleared.</li> </ul>
retired_branch_type			This event counts retiring branches by type. Specify one or more mask bits to qualify the branch by its type.
	ESCR restrictions	MSR_TBPU_ESCR0 MSR_TBPU_ESCR1	
	Counter numbers per ESCR	ESCR0: 4, 5 ESCR1: 6, 7	
	ESCR Event Select	04H	ESCR[30:25]
	ESCR Event Mask	Bit 1: CONDITIONAL 2: CALL 3: RETURN 4: INDIRECT	ESCR[24:9]  Conditional jumps. Direct or indirect calls. Return branches. Returns, indirect calls, or indirect jumps.
	CCCR Select	02H	CCCR[15:13]
	Event Specific Notes		This event may overcount conditional branches if : <ul style="list-style-type: none"> <li>▪ Mispredictions cause the trace cache and delivery engine to build new traces.</li> <li>▪ When the processor’s pipeline is being cleared.</li> </ul>



**Table 19-16. Performance Monitoring Events Supported by Intel NetBurst Microarchitecture for Non-Retirement Counting (Contd.)**

Event Name	Event Parameters	Parameter Value	Description
resource_stall			This event monitors the occurrence or latency of stalls in the Allocator.
	ESCR restrictions	MSR_ALF_ESCR0 MSR_ALF_ESCR1	
	Counter numbers per ESCR	ESCR0: 12, 13, 16 ESCR1: 14, 15, 17	
	ESCR Event Select	01H	ESCR[30:25]
	Event Masks	Bit 5: SBFULL	ESCR[24:9]  A Stall due to lack of store buffers.
	CCCR Select	01H	CCCR[15:13]
	Event Specific Notes		This event may not be supported in all models of the processor family.
WC_Buffer			This event counts Write Combining Buffer operations that are selected by the event mask.
	ESCR restrictions	MSR_DAC_ESCR0 MSR_DAC_ESCR1	
	Counter numbers per ESCR	ESCR0: 8, 9 ESCR1: 10, 11	
	ESCR Event Select	05H	ESCR[30:25]
	Event Masks	Bit 0: WCB_EVICTS	ESCR[24:9]  WC Buffer evictions of all causes.
		1: WCB_FULL_EVICT	WC Buffer eviction: no WC buffer is available.
	CCCR Select	05H	CCCR[15:13]

**Table 19-16. Performance Monitoring Events Supported by Intel NetBurst Microarchitecture for Non-Retirement Counting (Contd.)**

Event Name	Event Parameters	Parameter Value	Description
	Event Specific Notes		This event is useful for detecting the subset of 64K aliasing cases that are more costly (i.e. 64K aliasing cases involving stores) as long as there are no significant contributions due to write combining buffer full or hit-modified conditions.
b2b_cycles			This event can be configured to count the number back-to-back bus cycles using sub-event mask bits 1 through 6.
	ESCR restrictions	MSR_FSB_ESCR0 MSR_FSB_ESCR1	
	Counter numbers per ESCR	ESCR0: 0, 1 ESCR1: 2, 3	
	ESCR Event Select	016H	ESCR[30:25]
	Event Masks	Bit	ESCR[24:9]
	CCCR Select	03H	CCCR[15:13]
	Event Specific Notes		This event may not be supported in all models of the processor family.
bnr			This event can be configured to count bus not ready conditions using sub-event mask bits 0 through 2.
	ESCR restrictions	MSR_FSB_ESCR0 MSR_FSB_ESCR1	
	Counter numbers per ESCR	ESCR0: 0, 1 ESCR1: 2, 3	
	ESCR Event Select	08H	ESCR[30:25]
	Event Masks	Bit	ESCR[24:9]
	CCCR Select	03H	CCCR[15:13]
	Event Specific Notes		This event may not be supported in all models of the processor family.

**Table 19-16. Performance Monitoring Events Supported by Intel NetBurst Microarchitecture for Non-Retirement Counting (Contd.)**

Event Name	Event Parameters	Parameter Value	Description
snoop			This event can be configured to count snoop hit modified bus traffic using sub-event mask bits 2, 6 and 7.
	ESCR restrictions	MSR_FSB_ESCR0 MSR_FSB_ESCR1	
	Counter numbers per ESCR	ESCR0: 0, 1 ESCR1: 2, 3	
	ESCR Event Select	06H	ESCR[30:25]
	Event Masks	Bit	ESCR[24:9]
	CCCR Select	03H	CCCR[15:13]
	Event Specific Notes		This event may not be supported in all models of the processor family.
Response			This event can be configured to count different types of responses using sub-event mask bits 1,2, 8, and 9.
	ESCR restrictions	MSR_FSB_ESCR0 MSR_FSB_ESCR1	
	Counter numbers per ESCR	ESCR0: 0, 1 ESCR1: 2, 3	
	ESCR Event Select	04H	ESCR[30:25]
	Event Masks	Bit	ESCR[24:9]
	CCCR Select	03H	CCCR[15:13]
	Event Specific Notes		This event may not be supported in all models of the processor family.

**Table 19-17. Performance Monitoring Events For Intel NetBurst Microarchitecture for At-Retirement Counting**

Event Name	Event Parameters	Parameter Value	Description
front_end_event			This event counts the retirement of tagged $\mu$ ops, which are specified through the front-end tagging mechanism. The event mask specifies bogus or non-bogus $\mu$ ops.
	ESCR restrictions	MSR_CRU_ESCR2 MSR_CRU_ESCR3	
	Counter numbers per ESCR	ESCR2: 12, 13, 16 ESCR3: 14, 15, 17	
	ESCR Event Select	08H	ESCR[31:25]
	ESCR Event Mask	Bit 0: NBOGUS 1: BOGUS	ESCR[24:9]  The marked $\mu$ ops are not bogus. The marked $\mu$ ops are bogus.
	CCCR Select	05H	CCCR[15:13]
	Can Support PEBS	Yes	
	Require Additional MSRs for tagging	Selected ESCRs and/or MSR_TC_PRECISE_EVENT	See list of metrics supported by Front_end tagging in Table A-3
execution_event			This event counts the retirement of tagged $\mu$ ops, which are specified through the execution tagging mechanism.  The event mask allows from one to four types of $\mu$ ops to be specified as either bogus or non-bogus $\mu$ ops to be tagged.
	ESCR restrictions	MSR_CRU_ESCR2 MSR_CRU_ESCR3	
	Counter numbers per ESCR	ESCR2: 12, 13, 16 ESCR3: 14, 15, 17	
	ESCR Event Select	0CH	ESCR[31:25]

**Table 19-17. Performance Monitoring Events For Intel NetBurst Microarchitecture for At-Retirement Counting (Contd.)**

Event Name	Event Parameters	Parameter Value	Description
	ESCR Event Mask	Bit 0: NBOGUS0 1: NBOGUS1 2: NBOGUS2 3: NBOGUS3 4: BOGUS0 5: BOGUS1 6: BOGUS2 7: BOGUS3	ESCR[24:9]  The marked $\mu$ ops are not bogus. The marked $\mu$ ops are not bogus. The marked $\mu$ ops are not bogus. The marked $\mu$ ops are not bogus. The marked $\mu$ ops are bogus. The marked $\mu$ ops are bogus. The marked $\mu$ ops are bogus. The marked $\mu$ ops are bogus.
	CCCR Select	05H	CCCR[15:13]
	Event Specific Notes		Each of the 4 slots to specify the bogus/non-bogus $\mu$ ops must be coordinated with the 4 TagValue bits in the ESCR (for example, NBOGUS0 must accompany a '1' in the lowest bit of the TagValue field in ESCR, NBOGUS1 must accompany a '1' in the next but lowest bit of the TagValue field).
	Can Support PEBS	Yes	
	Require Additional MSRs for tagging	An ESCR for an upstream event	See list of metrics supported by execution tagging in Table A-4.
replay_event			This event counts the retirement of tagged $\mu$ ops, which are specified through the replay tagging mechanism. The event mask specifies bogus or non-bogus $\mu$ ops.
	ESCR restrictions	MSR_CRU_ESCR2 MSR_CRU_ESCR3	
	Counter numbers per ESCR	ESCR2: 12, 13, 16 ESCR3: 14, 15, 17	
	ESCR Event Select	09H	ESCR[31:25]

**Table 19-17. Performance Monitoring Events For Intel NetBurst Microarchitecture for At-Retirement Counting (Contd.)**

Event Name	Event Parameters	Parameter Value	Description
	ESCR Event Mask	Bit 0: NBOGUS 1: BOGUS	ESCR[24:9]  The marked $\mu$ ops are not bogus. The marked $\mu$ ops are bogus.
	CCCR Select	05H	CCCR[15:13]
	Event Specific Notes		Supports counting tagged $\mu$ ops with additional MSRs.
	Can Support PEBS	Yes	
	Require Additional MSRs for tagging	IA32_PEBS_ENABLE MSR_PEBS_MATRIX_VERT Selected ESCR	See list of metrics supported by replay tagging in Table A-5.
instr_retired			This event counts instructions that are retired during a clock cycle. Mask bits specify bogus or non-bogus (and whether they are tagged using the front-end tagging mechanism).
	ESCR restrictions	MSR_CRU_ESCR0 MSR_CRU_ESCR1	
	Counter numbers per ESCR	ESCR0: 12, 13, 16 ESCR1: 14, 15, 17	
	ESCR Event Select	02H	ESCR[31:25]
	ESCR Event Mask	Bit 0: NBOGUSNTAG  1: NBOGUSTAG  2: BOGUSNTAG  3: BOGUSTAG	ESCR[24:9]  Non-bogus instructions that are not tagged. Non-bogus instructions that are tagged. Bogus instructions that are not tagged. Bogus instructions that are tagged.
	CCCR Select	04H	CCCR[15:13]

**Table 19-17. Performance Monitoring Events For Intel NetBurst Microarchitecture for At-Retirement Counting (Contd.)**

Event Name	Event Parameters	Parameter Value	Description
	Event Specific Notes		<p>1: The event count may vary depending on the microarchitectural states of the processor when the event detection is enabled.</p> <p>2: The event may count more than once for some instructions with complex uop flows and were interrupted before retirement.</p>
	Can Support PEBS	No	
uops_retired			This event counts $\mu$ ops that are retired during a clock cycle. Mask bits specify bogus or non-bogus.
	ESCR restrictions	MSR_CRU_ESCR0 MSR_CRU_ESCR1	
	Counter numbers per ESCR	ESCR0: 12, 13, 16 ESCR1: 14, 15, 17	
	ESCR Event Select	01H	ESCR[31:25]
	ESCR Event Mask	Bit 0: NBOGUS 1: BOGUS	ESCR[24:9]  The marked $\mu$ ops are not bogus. The marked $\mu$ ops are bogus.
	CCCR Select	04H	CCCR[15:13]
	Event Specific Notes		P6: EMON_UOPS_RETIRED
	Can Support PEBS	No	
uop_type			This event is used in conjunction with the front-end at-retirement mechanism to tag load and store $\mu$ ops.
	ESCR restrictions	MSR_RAT_ESCR0 MSR_RAT_ESCR1	
	Counter numbers per ESCR	ESCR0: 12, 13, 16 ESCR1: 14, 15, 17	

**Table 19-17. Performance Monitoring Events For Intel NetBurst Microarchitecture for At-Retirement Counting (Contd.)**

Event Name	Event Parameters	Parameter Value	Description
	ESCR Event Select	02H	ESCR[31:25]
	ESCR Event Mask	Bit 1: TAGLOADS 2: TAGSTORES	ESCR[24:9]  The $\mu$ op is a load operation. The $\mu$ op is a store operation.
	CCCR Select	02H	CCCR[15:13]
	Event Specific Notes		Setting the TAGLOADS and TAGSTORES mask bits does not cause a counter to increment. They are only used to tag uops.
	Can Support PEBS	No	
branch_retired			This event counts the retirement of a branch. Specify one or more mask bits to select any combination of taken, not-taken, predicted and mispredicted.
	ESCR restrictions	MSR_CRU_ESCR2 MSR_CRU_ESCR3	See Table 18-31 for the addresses of the ESCR MSRs
	Counter numbers per ESCR	ESCR2: 12, 13, 16 ESCR3: 14, 15, 17	The counter numbers associated with each ESCR are provided. The performance counters and corresponding CCCRs can be obtained from Table 18-31.
	ESCR Event Select	06H	ESCR[31:25]
	ESCR Event Mask	Bit 0: MMNP 1: MMNM 2: MMTP 3: MMTM	ESCR[24:9]  Branch not-taken predicted Branch not-taken mispredicted Branch taken predicted Branch taken mispredicted
	CCCR Select	05H	CCCR[15:13]
	Event Specific Notes		P6: EMON_BR_INST_RETIRED
Can Support PEBS	No		



**Table 19-17. Performance Monitoring Events For Intel NetBurst Microarchitecture for At-Retirement Counting (Contd.)**

Event Name	Event Parameters	Parameter Value	Description
mispred_branch_retired			This event represents the retirement of mispredicted branch instructions.
	ESCR restrictions	MSR_CRU_ESCR0 MSR_CRU_ESCR1	
	Counter numbers per ESCR	ESCR0: 12, 13, 16 ESCR1: 14, 15, 17	
	ESCR Event Select	03H	ESCR[31:25]
	ESCR Event Mask	Bit 0: NBOGUS	ESCR[24:9] The retired instruction is not bogus.
	CCCR Select	04H	CCCR[15:13]
	Can Support PEBS	No	
x87_assist			This event counts the retirement of x87 instructions that required special handling. Specifies one or more event mask bits to select the type of assistance.
	ESCR restrictions	MSR_CRU_ESCR2 MSR_CRU_ESCR3	
	Counter numbers per ESCR	ESCR2: 12, 13, 16 ESCR3: 14, 15, 17	
	ESCR Event Select	03H	ESCR[31:25]
	ESCR Event Mask	Bit 0: FPSU 1: FPSO 2: POAO 3: POAU 4: PREA	ESCR[24:9] Handle FP stack underflow Handle FP stack overflow Handle x87 output overflow Handle x87 output underflow Handle x87 input assist
	CCCR Select	05H	CCCR[15:13]
	Can Support PEBS	No	

**Table 19-17. Performance Monitoring Events For Intel NetBurst Microarchitecture for At-Retirement Counting (Contd.)**

Event Name	Event Parameters	Parameter Value	Description
machine_clear			This event increments according to the mask bit specified while the entire pipeline of the machine is cleared. Specify one of the mask bit to select the cause.
	ESCR restrictions	MSR_CRU_ESCR2 MSR_CRU_ESCR3	
	Counter numbers per ESCR	ESCR2: 12, 13, 16 ESCR3: 14, 15, 17	
	ESCR Event Select	02H	ESCR[31:25]
	ESCR Event Mask	Bit 0: CLEAR  2: MOCLEAR  6: SMCLEAR	ESCR[24:9]  Counts for a portion of the many cycles while the machine is cleared for any cause. Use Edge triggering for this bit only to get a count of occurrence versus a duration.  Increments each time the machine is cleared due to memory ordering issues.  Increments each time the machine is cleared due to self-modifying code issues.
	CCCR Select	05H	CCCR[15:13]
	Can Support PEBS	No	

**Table 19-18. Intel NetBurst Microarchitecture Model-Specific Performance Monitoring Events (For Model Encoding 3, 4 or 6)**

Event Name	Event Parameters	Parameter Value	Description
instr_completed			This event counts instructions that have completed and retired during a clock cycle. Mask bits specify whether the instruction is bogus or non-bogus and whether they are:
	ESCR restrictions	MSR_CRU_ESCR0 MSR_CRU_ESCR1	
	Counter numbers per ESCR	ESCR0: 12, 13, 16 ESCR1: 14, 15, 17	
	ESCR Event Select	07H	ESCR[31:25]
	ESCR Event Mask	Bit 0: NBOGUS 1: BOGUS	ESCR[24:9]  Non-bogus instructions Bogus instructions
	CCCR Select	04H	CCCR[15:13]
	Event Specific Notes		This metric differs from instr_retired, since it counts instructions completed, rather than the number of times that instructions started.
	Can Support PEBS	No	

**Table 19-19. List of Metrics Available for Front\_end Tagging  
(For Front\_end Event Only)**

Front-end metric <sup>1</sup>	MSR_TC_PRECISE_EVENT MSR Bit field	Additional MSR	Event mask value for Front_end_event
memory_loads	None	Set TAGLOADS bit in ESCR corresponding to event Uop_Type.	NBOGUS
memory_stores	None	Set TAGSTORES bit in the ESCR corresponding to event Uop_Type.	NBOGUS

**NOTES:**

1. There may be some undercounting of front end events when there is an overflow or underflow of the floating point stack.

**Table 19-20. List of Metrics Available for Execution Tagging  
(For Execution Event Only)**

Execution metric	Upstream ESCR	TagValue in Upstream ESCR	Event mask value for execution_event
packed_SP_retired	Set ALL bit in event mask, TagUop bit in ESCR of packed_SP_uop.	1	NBOGUS0
packed_DP_retired	Set ALL bit in event mask, TagUop bit in ESCR of packed_DP_uop.	1	NBOGUS0
scalar_SP_retired	Set ALL bit in event mask, TagUop bit in ESCR of scalar_SP_uop.	1	NBOGUS0
scalar_DP_retired	Set ALL bit in event mask, TagUop bit in ESCR of scalar_DP_uop.	1	NBOGUS0
128_bit_MMX_retired	Set ALL bit in event mask, TagUop bit in ESCR of 128_bit_MMX_uop.	1	NBOGUS0

**Table 19-20. List of Metrics Available for Execution Tagging  
(For Execution Event Only) (Contd.)**

Execution metric	Upstream ESCR	TagValue in Upstream ESCR	Event mask value for execution_event
64_bit_MMX_retired	Set ALL bit in event mask, TagUop bit in ESCR of 64_bit_MMX_uop.	1	NBOGUSO
X87_FP_retired	Set ALL bit in event mask, TagUop bit in ESCR of x87_FP_uop.	1	NBOGUSO
X87_SIMD_memory_moves_retired	Set ALLP0, ALLP2 bits in event mask, TagUop bit in ESCR of X87_SIMD_moves_uop.	1	NBOGUSO

**Table 19-21. List of Metrics Available for Replay Tagging  
(For Replay Event Only)**

Replay metric <sup>1</sup>	IA32_PEBS_ENABLE Field to Set	MSR_PEBS_MATRIX_VERT Bit Field to Set	Additional MSR/Event	Event Mask Value for Replay_event
1stL_cache_load_miss_retired	Bit 0, Bit 24, Bit 25	Bit 0	None	NBOGUS
2ndL_cache_load_miss_retired <sup>2</sup>	Bit 1, Bit 24, Bit 25	Bit 0	None	NBOGUS
DTLB_load_miss_retired	Bit 2, Bit 24, Bit 25	Bit 0	None	NBOGUS
DTLB_store_miss_retired	Bit 2, Bit 24, Bit 25	Bit 1	None	NBOGUS
DTLB_all_miss_retired	Bit 2, Bit 24, Bit 25	Bit 0, Bit 1	None	NBOGUS
Tagged_mispred_branch	Bit 15, Bit 16, Bit 24, Bit 25	Bit 4	None	NBOGUS
MOB_load_replay_retired <sup>3</sup>	Bit 9, Bit 24, Bit 25	Bit 0	Select MOB_load_replay event and set PARTIAL_DATA and UNALGN_ADDR bit.	NBOGUS

**Table 19-21. List of Metrics Available for Replay Tagging  
(For Replay Event Only) (Contd.)**

Replay metric <sup>1</sup>	IA32_PEBS_ENABLE Field to Set	MSR_PEBS_MATRIX_VERT Bit Field to Set	Additional MSR/ Event	Event Mask Value for Replay_event
split_load_retired	Bit 10, Bit 24, Bit 25	Bit 0	Select load_port_replay event with the MSR_SAAT_ESCR1 MSR and set the SPLIT_LD mask bit.	NBOGUS
split_store_retired	Bit 10, Bit 24, Bit 25	Bit 1	Select store_port_replay event with the MSR_SAAT_ESCR0 MSR and set the SPLIT_ST mask bit.	NBOGUS

**NOTES:**

1. Certain kinds of  $\mu$ ops cannot be tagged. These include I/O operations, UC and locked accesses, returns, and far transfers.
2. 2nd-level misses retired does not count all 2nd-level misses. It only includes those references that are found to be misses by the fast detection logic and not those that are later found to be misses.
3. While there are several causes for a MOB replay, the event counted with this event mask setting is the case where the data from a load that would otherwise be forwarded is not an aligned subset of the data from a preceding store.

**Table 19-22. Event Mask Qualification for Logical Processors**

Event Type	Event Name	Event Masks, ESCR[24:9]	TS or TI
Non-Retirement	BPU_fetch_request	Bit 0: TCMISS	TS
Non-Retirement	BSQ_allocation	Bit 0: REQ_TYPE0 1: REQ_TYPE1 2: REQ_LEN0 3: REQ_LEN1 5: REQ_IO_TYPE 6: REQ_LOCK_TYPE 7: REQ_CACHE_TYPE 8: REQ_SPLIT_TYPE 9: REQ_DEM_TYPE 10: REQ_ORD_TYPE 11: MEM_TYPE0 12: MEM_TYPE1 13: MEM_TYPE2	TS TS TS TS TS TS TS TS TS TS TS TS TS
Non-Retirement	BSQ_cache_reference	Bit 0: RD_2ndL_HITS 1: RD_2ndL_HITE 2: RD_2ndL_HITM 3: RD_3rdL_HITS 4: RD_3rdL_HITE 5: RD_3rdL_HITM 6: WR_2ndL_HIT 7: WR_3rdL_HIT 8: RD_2ndL_MISS 9: RD_3rdL_MISS 10: WR_2ndL_MISS 11: WR_3rdL_MISS	TS TS TS TS TS TS TS TS TS TS TS TS

**Table 19-22. Event Mask Qualification for Logical Processors (Contd.)**

Event Type	Event Name	Event Masks, ESCR[24:9]	TS or TI
Non-Retirement	memory_cancel	Bit	
		2: ST_RB_FULL	TS
		3: 64K_CONF	TS
Non-Retirement	SSE_input_assist	Bit 15: ALL	TI
Non-Retirement	64bit_MMX_uop	Bit 15: ALL	TI
Non-Retirement	packed_DP_uop	Bit 15: ALL	TI
Non-Retirement	packed_SP_uop	Bit 15: ALL	TI
Non-Retirement	scalar_DP_uop	Bit 15: ALL	TI
Non-Retirement	scalar_SP_uop	Bit 15: ALL	TI
Non-Retirement	128bit_MMX_uop	Bit 15: ALL	TI
Non-Retirement	x87_FP_uop	Bit 15: ALL	TI
Non-Retirement	x87_SIMD_moves_uop	Bit	
		3: ALLP0	TI
		4: ALLP2	TI
Non-Retirement	FSB_data_activity	Bit	
		0: DRDY_DRV	TI
		1: DRDY_OWN	TI
		2: DRDY_OTHER	TI
		3: DBSY_DRV	TI
		4: DBSY_OWN	TI
5: DBSY_OTHER	TI		
Non-Retirement	IOQ_allocation	Bit	
		0: ReqA0	TS
		1: ReqA1	TS
		2: ReqA2	TS
		3: ReqA3	TS
		4: ReqA4	TS
		5: ALL_READ	TS
		6: ALL_WRITE	TS
		7: MEM_UC	TS
8: MEM_WC	TS		



**Table 19-22. Event Mask Qualification for Logical Processors (Contd.)**

Event Type	Event Name	Event Masks, ESCR[24:9]	TS or TI
		9: MEM_WT 10: MEM_WP 11: MEM_WB 13: OWN 14: OTHER 15: PREFETCH	TS TS TS TS TS TS
Non-Retirement	IOQ_active_entries	Bit 0: ReqA0 1: ReqA1 2: ReqA2 3: ReqA3 4: ReqA4 5: ALL_READ 6: ALL_WRITE 7: MEM_UC 8: MEM_WC 9: MEM_WT 10: MEM_WP 11: MEM_WB 13: OWN 14: OTHER 15: PREFETCH	TS  TS TS TS TS TS TS TS TS TS TS TS TS TS
Non-Retirement	global_power_events	Bit 0: RUNNING	TS
Non-Retirement	ITLB_reference	Bit 0: HIT 1: MISS 2: HIT_UC	TS TS TS

**Table 19-22. Event Mask Qualification for Logical Processors (Contd.)**

Event Type	Event Name	Event Masks, ESCR[24:9]	TS or TI
Non-Retirement	MOB_load_replay	Bit	
		1: NO_STA	TS
		3: NO_STD	TS
		4: PARTIAL_DATA	TS
		5: UNALGN_ADDR	TS
Non-Retirement	page_walk_type	Bit	
		0: DTMISS	TI
		1: ITMISS	TI
Non-Retirement	uop_type	Bit	
		1: TAGLOADS	TS
		2: TAGSTORES	TS
Non-Retirement	load_port_replay	Bit 1: SPLIT_LD	TS
Non-Retirement	store_port_replay	Bit 1: SPLIT_ST	TS
Non-Retirement	memory_complete	Bit	
		0: LSC	TS
		1: SSC	TS
		2: USC	TS
		3: ULC	TS
Non-Retirement	retired_mispred_branch_type	Bit	
		0: UNCONDITIONAL	TS
		1: CONDITIONAL	TS
		2: CALL	TS
		3: RETURN	TS
		4: INDIRECT	TS
Non-Retirement	retired_branch_type	Bit	
		0: UNCONDITIONAL	TS
		1: CONDITIONAL	TS
		2: CALL	TS
		3: RETURN	TS
		4: INDIRECT	TS

**Table 19-22. Event Mask Qualification for Logical Processors (Contd.)**

Event Type	Event Name	Event Masks, ESCR[24:9]	TS or TI
Non-Retirement	tc_ms_xfer	Bit 0: CISC	TS
Non-Retirement	tc_misc	Bit 4: FLUSH	TS
Non-Retirement	TC_deliver_mode	Bit 0: DD	TI
		1: DB	TI
		2: DI	TI
		3: BD	TI
		4: BB	TI
		5: BI	TI
		6: ID	TI
		7: IB	TI
Non-Retirement	uop_queue_writes	Bit 0: FROM_TC_BUILD	TS
		1: FROM_TC_DELIVER	TS
		2: FROM_ROM	TS
Non-Retirement	resource_stall	Bit 5: SBFULL	TS
Non-Retirement	wC_Buffer	Bit 0: WCB_EVICTS	TI
		1: WCB_FULL_EVICT	TI
		2: WCB_HITM_EVICT	TI
At Retirement	instr_retired	Bit 0: NBOGUSNTAG	TS
		1: NBOGUSTAG	TS
		2: BOGUSNTAG	TS
		3: BOGUSTAG	TS

**Table 19-22. Event Mask Qualification for Logical Processors (Contd.)**

Event Type	Event Name	Event Masks, ESCR[24:9]	TS or TI
At Retirement	machine_clear	Bit 0: CLEAR 2: MOCLEAR 6: SMCCLLEAR	TS TS TS
At Retirement	front_end_event	Bit 0: NBOGUS 1: BOGUS	TS TS
At Retirement	replay_event	Bit 0: NBOGUS 1: BOGUS	TS TS
At Retirement	execution_event	Bit 0: NONBOGUS0 1: NONBOGUS1 2: NONBOGUS2 3: NONBOGUS3 4: BOGUS0 5: BOGUS1 6: BOGUS2 7: BOGUS3	TS TS TS TS TS TS TS TS
At Retirement	x87_assist	Bit 0: FPSU 1: FPSO 2: POAO 3: POAU 4: PREA	TS TS TS TS TS
At Retirement	branch_retired	Bit 0: MMNP 1: MMNM 2: MMTP 3: MMTM	TS TS TS TS
At Retirement	mispred_branch_retired	Bit 0: NBOGUS	TS

**Table 19-22. Event Mask Qualification for Logical Processors (Contd.)**

Event Type	Event Name	Event Masks, ESCR[24:9]	TS or TI
At Retirement	uops_retired	Bit	
		0: NBOGUS	TS
At Retirement	instr_completed	1: BOGUS	TS
		Bit	
At Retirement	instr_completed	0: NBOGUS	TS
		1: BOGUS	TS

## 19.11 PERFORMANCE MONITORING EVENTS FOR INTEL® PENTIUM® M PROCESSORS

The Pentium M processor's performance-monitoring events are based on monitoring events for the P6 family of processors. All of these performance events are model specific for the Pentium M processor and are not available in this form in other processors. Table 19-23 lists the Performance-Monitoring events that were added in the Pentium M processor.

**Table 19-23. Performance Monitoring Events on Intel® Pentium® M Processors**

Name	Hex Values	Descriptions
Power Management		
EMON_EST_TRANS	58H	Number of Enhanced Intel SpeedStep technology transitions: Mask = 00H - All transitions Mask = 02H - Only Frequency transitions
EMON_THERMAL_TRIP	59H	Duration/Occurrences in thermal trip; to count number of thermal trips: bit 22 in PerfEvtSel0/1 needs to be set to enable edge detect.
BPU		
BR_INST_EXEC	88H	Branch instructions that were executed (not necessarily retired).
BR_MISSP_EXEC	89H	Branch instructions executed that were mispredicted at execution.

**Table 19-23. Performance Monitoring Events on Intel® Pentium® M Processors (Contd.)**

Name	Hex Values	Descriptions
BR_BAC_MISSP_EXEC	8AH	Branch instructions executed that were mispredicted at front end (BAC).
BR_CND_EXEC	8BH	Conditional branch instructions that were executed.
BR_CND_MISSP_EXEC	8CH	Conditional branch instructions executed that were mispredicted.
BR_IND_EXEC	8DH	Indirect branch instructions executed.
BR_IND_MISSP_EXEC	8EH	Indirect branch instructions executed that were mispredicted.
BR_RET_EXEC	8FH	Return branch instructions executed.
BR_RET_MISSP_EXEC	90H	Return branch instructions executed that were mispredicted at execution.
BR_RET_BAC_MISSP_EXEC	91H	Return branch instructions executed that were mispredicted at front end (BAC).
BR_CALL_EXEC	92H	CALL instruction executed.
BR_CALL_MISSP_EXEC	93H	CALL instruction executed and miss predicted.
BR_IND_CALL_EXEC	94H	Indirect CALL instructions executed.
Decoder		
EMON_SIMD_INSTR_RETIRED	CEH	Number of retired MMX instructions.
EMON_SYNCH_UOPS	D3H	Sync micro-ops
EMON_ESP_UOPS	D7H	Total number of micro-ops
EMON_FUSED_UOPS_RET	DAH	Number of retired fused micro-ops: Mask = 0 - Fused micro-ops Mask = 1 - Only load+Op micro-ops Mask = 2 - Only std+sta micro-ops
EMON_UNFUSION	DBH	Number of unfusion events in the ROB, happened on a FP exception to a fused $\mu$ op.

**Table 19-23. Performance Monitoring Events on Intel® Pentium® M Processors (Contd.)**

Name	Hex Values	Descriptions
Prefetcher		
EMON_PREF_RQSTS_UP	F0H	Number of upward prefetches issued
EMON_PREF_RQSTS_DN	F8H	Number of downward prefetches issued

A number of P6 family processor performance monitoring events are modified for the Pentium M processor. Table 19-24 lists the performance monitoring events that were changed in the Pentium M processor, and differ from performance monitoring events for the P6 family of processors.

**Table 19-24. Performance Monitoring Events Modified on Intel® Pentium® M Processors**

Name	Hex Values	Descriptions
CPU_CLK_UNHALTED	79H	Number of cycles during which the processor is not halted, and not in a thermal trip.
EMON_SSE_SSE2_INST_RETIRE	D8H	Streaming SIMD Extensions Instructions Retired: Mask = 0 - SSE packed single and scalar single Mask = 1 - SSE scalar-single Mask = 2 - SSE2 packed-double Mask = 3 - SSE2 scalar-double
EMON_SSE_SSE2_COMP_INST_RETIRE	D9H	Computational SSE Instructions Retired: Mask = 0 - SSE packed single Mask = 1 - SSE Scalar-single Mask = 2 - SSE2 packed-double Mask = 3 - SSE2 scalar-double

**Table 19-24. Performance Monitoring Events Modified on Intel® Pentium® M Processors (Contd.)**

Name	Hex Values	Descriptions	
L2_LD	29H	L2 data loads	Mask[0] = 1 - count I state lines
L2_LINES_IN	24H	L2 lines allocated	Mask[1] = 1 - count S state lines
L2_LINES_OUT	26H	L2 lines evicted	Mask[2] = 1 - count E state lines
L2_M_LINES_OUT	27H	Lw M-state lines evicted	Mask[3] = 1 - count M state lines Mask[5:4]: 00H - Excluding hardware-prefetched lines 01H - Hardware-prefetched lines only 02H/03H - All (HW-prefetched lines and non HW --Prefetched lines)

## 19.12 P6 FAMILY PROCESSOR PERFORMANCE-MONITORING EVENTS

Table 19-25 lists the events that can be counted with the performance-monitoring counters and read with the RDPMC instruction for the P6 family processors. The unit column gives the microarchitecture or bus unit that produces the event; the event number column gives the hexadecimal number identifying the event; the mnemonic event name column gives the name of the event; the unit mask column gives the unit mask required (if any); the description column describes the event; and the comments column gives additional information about the event.

All of these performance events are model specific for the P6 family processors and are not available in this form in the Pentium 4 processors or the Pentium processors. Some events (such as those added in later generations of the P6 family processors) are only available in specific processors in the P6 family. All performance event encodings not listed in Table 19-25 are reserved and their use will result in undefined counter results.

See the end of the table for notes related to certain entries in the table.



**Table 19-25. Events That Can Be Counted with the P6 Family Performance-Monitoring Counters**

Unit	Event Num.	Mnemonic Event Name	Unit Mask	Description	Comments
Data Cache Unit (DCU)	43H	DATA_MEM_REFS	00H	<p>All loads from any memory type. All stores to any memory type. Each part of a split is counted separately. The internal logic counts not only memory loads and stores, but also internal retries.</p> <p>80-bit floating-point accesses are double counted, since they are decomposed into a 16-bit exponent load and a 64-bit mantissa load. Memory accesses are only counted when they are actually performed (such as a load that gets squashed because a previous cache miss is outstanding to the same address, and which finally gets performed, is only counted once).</p> <p>Does not include I/O accesses, or other nonmemory accesses.</p>	
	45H	DCU_LINES_IN	00H	Total lines allocated in DCU.	
	46H	DCU_M_LINES_IN	00H	Number of M state lines allocated in DCU.	
	47H	DCU_M_LINES_OUT	00H	<p>Number of M state lines evicted from DCU.</p> <p>This includes evictions via snoop HITM, intervention or replacement.</p>	

**Table 19-25. Events That Can Be Counted with the P6 Family Performance-Monitoring Counters (Contd.)**

Unit	Event Num.	Mnemonic Event Name	Unit Mask	Description	Comments
	48H	DCU_MISS_OUTSTANDING	00H	<p>Weighted number of cycles while a DCU miss is outstanding, incremented by the number of outstanding cache misses at any particular time.</p> <p>Cacheable read requests only are considered. Uncacheable requests are excluded.</p> <p>Read-for-ownerships are counted, as well as line fills, invalidates, and stores.</p>	<p>An access that also misses the L2 is short-changed by 2 cycles (i.e., if counts N cycles, should be N+2 cycles).</p> <p>Subsequent loads to the same cache line will not result in any additional counts.</p> <p>Count value not precise, but still useful.</p>
Instruction Fetch Unit (IFU)	80H	IFU_IFETCH	00H	Number of instruction fetches, both cacheable and noncacheable, including UC fetches.	
	81H	IFU_IFETCH_MISS	00H	<p>Number of instruction fetch misses</p> <p>All instruction fetches that do not hit the IFU (i.e., that produce memory requests). This includes UC accesses.</p>	
	85H	ITLB_MISS	00H	Number of ITLB misses.	
	86H	IFU_MEM_STALL	00H	<p>Number of cycles instruction fetch is stalled, for any reason.</p> <p>Includes IFU cache misses, ITLB misses, ITLB faults, and other minor stalls.</p>	
	87H	ILD_STALL	00H	Number of cycles that the instruction length decoder is stalled.	

**Table 19-25. Events That Can Be Counted with the P6 Family Performance-Monitoring Counters (Contd.)**

Unit	Event Num.	Mnemonic Event Name	Unit Mask	Description	Comments
L2 Cache <sup>1</sup>	28H	L2_IFETCH	MESI OFH	<p>Number of L2 instruction fetches.</p> <p>This event indicates that a normal instruction fetch was received by the L2.</p> <p>The count includes only L2 cacheable instruction fetches; it does not include UC instruction fetches.</p> <p>It does not include ITLB miss accesses.</p>	
	29H	L2_LD	MESI OFH	<p>Number of L2 data loads.</p> <p>This event indicates that a normal, unlocked, load memory access was received by the L2.</p> <p>It includes only L2 cacheable memory accesses; it does not include I/O accesses, other nonmemory accesses, or memory accesses such as UC/WT memory accesses.</p> <p>It does include L2 cacheable TLB miss memory accesses.</p>	
	2AH	L2_ST	MESI OFH	<p>Number of L2 data stores.</p> <p>This event indicates that a normal, unlocked, store memory access was received by the L2.</p>	

**Table 19-25. Events That Can Be Counted with the P6 Family Performance-Monitoring Counters (Contd.)**

Unit	Event Num.	Mnemonic Event Name	Unit Mask	Description	Comments
				<p>it indicates that the DCU sent a read-for-ownership request to the L2. It also includes Invalid to Modified requests sent by the DCU to the L2.</p> <p>It includes only L2 cacheable memory accesses; it does not include I/O accesses, other nonmemory accesses, or memory accesses such as UC/WT memory accesses.</p> <p>It includes TLB miss memory accesses.</p>	
	24H	L2_LINES_IN	00H	Number of lines allocated in the L2.	
	26H	L2_LINES_OUT	00H	Number of lines removed from the L2 for any reason.	
	25H	L2_M_LINES_INM	00H	Number of modified lines allocated in the L2.	
	27H	L2_M_LINES_OUTM	00H	Number of modified lines removed from the L2 for any reason.	
	2EH	L2_RQSTS	MESI 0FH	Total number of L2 requests.	
	21H	L2_ADS	00H	Number of L2 address strobes.	
	22H	L2_DBUS_BUSY	00H	Number of cycles during which the L2 cache data bus was busy.	
	23H	L2_DBUS_BUSY_RD	00H	Number of cycles during which the data bus was busy transferring read data from L2 to the processor.	

**Table 19-25. Events That Can Be Counted with the P6 Family Performance-Monitoring Counters (Contd.)**

Unit	Event Num.	Mnemonic Event Name	Unit Mask	Description	Comments
External Bus Logic (EBL) <sup>2</sup>	62H	BUS_DRDY_CLOCKS	00H (Self) 20H (Any)	Number of clocks during which DRDY# is asserted. Utilization of the external system data bus during data transfers.	Unit Mask = 00H counts bus clocks when the processor is driving DRDY#. Unit Mask = 20H counts in processor clocks when any agent is driving DRDY#.
	63H	BUS_LOCK_CLOCKS	00H (Self) 20H (Any)	Number of clocks during which LOCK# is asserted on the external system bus. <sup>3</sup>	Always counts in processor clocks.
	60H	BUS_REQ_OUTSTANDING	00H (Self)	Number of bus requests outstanding. This counter is incremented by the number of cacheable read bus requests outstanding in any given cycle.	Counts only DCU full-line cacheable reads, not RFOs, writes, instruction fetches, or anything else. Counts "waiting for bus to complete" (last data chunk received).
	65H	BUS_TRAN_BRD	00H (Self) 20H (Any)	Number of burst read transactions.	
	66H	BUS_TRAN_RFO	00H (Self) 20H (Any)	Number of completed read for ownership transactions.	
	67H	BUS_TRANS_WB	00H (Self) 20H (Any)	Number of completed write back transactions.	

**Table 19-25. Events That Can Be Counted with the P6 Family Performance-Monitoring Counters (Contd.)**

Unit	Event Num.	Mnemonic Event Name	Unit Mask	Description	Comments
	68H	BUS_TRAN_IFETCH	00H (Self) 20H (Any)	Number of completed instruction fetch transactions.	
	69H	BUS_TRAN_INVALID	00H (Self) 20H (Any)	Number of completed invalidate transactions.	
	6AH	BUS_TRAN_PWR	00H (Self) 20H (Any)	Number of completed partial write transactions.	
	6BH	BUS_TRANS_P	00H (Self) 20H (Any)	Number of completed partial transactions.	
	6CH	BUS_TRANS_IO	00H (Self) 20H (Any)	Number of completed I/O transactions.	
	6DH	BUS_TRAN_DEF	00H (Self) 20H (Any)	Number of completed deferred transactions.	
	6EH	BUS_TRAN_BURST	00H (Self) 20H (Any)	Number of completed burst transactions.	
	70H	BUS_TRAN_ANY	00H (Self) 20H (Any)	Number of all completed bus transactions. Address bus utilization can be calculated knowing the minimum address bus occupancy. Includes special cycles, etc.	

**Table 19-25. Events That Can Be Counted with the P6 Family Performance-Monitoring Counters (Contd.)**

Unit	Event Num.	Mnemonic Event Name	Unit Mask	Description	Comments
	6FH	BUS_TRAN_MEM	00H (Self) 20H (Any)	Number of completed memory transactions.	
	64H	BUS_DATA_RCV	00H (Self)	Number of bus clock cycles during which this processor is receiving data.	
	61H	BUS_BNR_DRV	00H (Self)	Number of bus clock cycles during which this processor is driving the BNR# pin.	
	7AH	BUS_HIT_DRV	00H (Self)	Number of bus clock cycles during which this processor is driving the HIT# pin.	<p>Includes cycles due to snoop stalls.</p> <p>The event counts correctly, but BPM<i>i</i> (breakpoint monitor) pins function as follows based on the setting of the PC bits (bit 19 in the PerfEvtSel0 and PerfEvtSel1 registers):</p> <ul style="list-style-type: none"> <li>▪ If the core-clock-to-bus-clock ratio is 2:1 or 3:1, and a PC bit is set, the BPM<i>i</i> pins will be asserted for a single clock when the counters overflow.</li> </ul>

**Table 19-25. Events That Can Be Counted with the P6 Family Performance-Monitoring Counters (Contd.)**

Unit	Event Num.	Mnemonic Event Name	Unit Mask	Description	Comments
					<ul style="list-style-type: none"> <li>▪ If the PC bit is clear, the processor toggles the BPM<sub>i</sub> pins when the counter overflows.</li> <li>▪ If the clock ratio is not 2:1 or 3:1, the BPM<sub>i</sub> pins will not function for these performance-monitoring counter events.</li> </ul>
	7BH	BUS_HITM_DRV	OOH (Self)	Number of bus clock cycles during which this processor is driving the HITM# pin.	<p>Includes cycles due to snoop stalls.</p> <p>The event counts correctly, but BPM<sub>i</sub> (breakpoint monitor) pins function as follows based on the setting of the PC bits (bit 19 in the PerfEvtSel0 and PerfEvtSel1 registers):</p> <ul style="list-style-type: none"> <li>▪ If the core-clock-to-bus-clock ratio is 2:1 or 3:1, and a PC bit is set, the BPM<sub>i</sub> pins will be asserted for a single clock when the counters overflow.</li> </ul>



**Table 19-25. Events That Can Be Counted with the P6 Family Performance-Monitoring Counters (Contd.)**

Unit	Event Num.	Mnemonic Event Name	Unit Mask	Description	Comments
					<ul style="list-style-type: none"> <li>▪ If the PC bit is clear, the processor toggles the BPM<sub>i</sub> pins when the counter overflows.</li> <li>▪ If the clock ratio is not 2:1 or 3:1, the BPM<sub>i</sub> pins will not function for these performance-monitoring counter events.</li> </ul>
	7EH	BUS_SNOOP_STALL	00H (Self)	Number of clock cycles during which the bus is snoop stalled.	
Floating-Point Unit	C1H	FLOPS	00H	<p>Number of computational floating-point operations retired.</p> <p>Excludes floating-point computational operations that cause traps or assists.</p> <p>Includes floating-point computational operations executed by the assist handler.</p> <p>Includes internal sub-operations for complex floating-point instructions like transcendentals.</p> <p>Excludes floating-point loads and stores.</p>	Counter 0 only.

**Table 19-25. Events That Can Be Counted with the P6 Family Performance-Monitoring Counters (Contd.)**

Unit	Event Num.	Mnemonic Event Name	Unit Mask	Description	Comments
	10H	FP_COMP_OPS_EXE	00H	<p>Number of computational floating-point operations executed.</p> <p>The number of FADD, FSUB, FCOM, FMULs, integer MULs and IMULs, FDIVs, FPREMs, FSQRTS, integer DIVs, and IDIVs.</p> <p>This number does not include the number of cycles, but the number of operations.</p> <p>This event does not distinguish an FADD used in the middle of a transcendental flow from a separate FADD instruction.</p>	Counter 0 only.
	11H	FP_ASSIST	00H	Number of floating-point exception cases handled by microcode.	Counter 1 only. This event includes counts due to speculative execution.
	12H	MUL	00H	<p>Number of multiplies.</p> <p>This count includes integer as well as FP multiplies and is speculative.</p>	Counter 1 only.
	13H	DIV	00H	<p>Number of divides.</p> <p>This count includes integer as well as FP divides and is speculative.</p>	Counter 1 only.

**Table 19-25. Events That Can Be Counted with the P6 Family Performance-Monitoring Counters (Contd.)**

Unit	Event Num.	Mnemonic Event Name	Unit Mask	Description	Comments
	14H	CYCLES_DIV_BUSY	00H	Number of cycles during which the divider is busy, and cannot accept new divides.  This includes integer and FP divides, FPREM, FPSQRT, etc. and is speculative.	Counter 0 only.
Memory Ordering	03H	LD_BLOCKS	00H	Number of load operations delayed due to store buffer blocks.  Includes counts caused by preceding stores whose addresses are unknown, preceding stores whose addresses are known but whose data is unknown, and preceding stores that conflicts with the load but which incompletely overlap the load.	
	04H	SB_DRAINS	00H	Number of store buffer drain cycles.  Incremented every cycle the store buffer is draining.  Draining is caused by serializing operations like CPUID, synchronizing operations like XCHG, interrupt acknowledgment, as well as other conditions (such as cache flushing).	

**Table 19-25. Events That Can Be Counted with the P6 Family Performance-Monitoring Counters (Contd.)**

Unit	Event Num.	Mnemonic Event Name	Unit Mask	Description	Comments
	05H	MISALIGN_MEM_REF	00H	<p>Number of misaligned data memory references. Incremented by 1 every cycle, during which either the processor's load or store pipeline dispatches a misaligned <math>\mu</math>op.</p> <p>Counting is performed if it is the first or second half, or if it is blocked, squashed, or missed.</p> <p>In this context, misaligned means crossing a 64-bit boundary.</p>	<p>MISALIGN_MEM_REF is only an approximation to the true number of misaligned memory references.</p> <p>The value returned is roughly proportional to the number of misaligned memory accesses (the size of the problem).</p>
	07H	EMON_KNI_PREF_DISPATCHED	00H 01H 02H 03H	<p>Number of Streaming SIMD extensions prefetch/weakly-ordered instructions dispatched (speculative prefetches are included in counting):</p> <p>0: prefetch NTA            1: prefetch T1            2: prefetch T2            3: weakly ordered stores</p>	Counters 0 and 1. Pentium III processor only.
	4BH	EMON_KNI_PREF_MISS	00H 01H 02H 03H	<p>Number of prefetch/weakly-ordered instructions that miss all caches:</p> <p>0: prefetch NTA            1: prefetch T1            2: prefetch T2            3: weakly ordered stores</p>	Counters 0 and 1. Pentium III processor only.

**Table 19-25. Events That Can Be Counted with the P6 Family Performance-Monitoring Counters (Contd.)**

Unit	Event Num.	Mnemonic Event Name	Unit Mask	Description	Comments
Instruction Decoding and Retirement	C0H	INST_RETIRED	00H	Number of instructions retired.	A hardware interrupt received during/after the last iteration of the REP STOS flow causes the counter to undercount by 1 instruction.  An SMI received while executing a HLT instruction will cause the performance counter to not count the RSM instruction and undercount by 1.
	C2H	UOPS_RETIRED	00H	Number of $\mu$ ops retired.	
	D0H	INST_DECODED	00H	Number of instructions decoded.	
	D8H	EMON_KNI_INST_RETIRED	00H 01H	Number of Streaming SIMD extensions retired: 0: packed & scalar 1: scalar	Counters 0 and 1. Pentium III processor only.
	D9H	EMON_KNI_COMP_INST_RET	00H 01H	Number of Streaming SIMD extensions computation instructions retired: 0: packed and scalar 1: scalar	Counters 0 and 1. Pentium III processor only.

**Table 19-25. Events That Can Be Counted with the P6 Family Performance-Monitoring Counters (Contd.)**

Unit	Event Num.	Mnemonic Event Name	Unit Mask	Description	Comments
Interrupts	C8H	HW_INT_RX	00H	Number of hardware interrupts received.	
	C6H	CYCLES_INT_MASKED	00H	Number of processor cycles for which interrupts are disabled.	
	C7H	CYCLES_INT_PENDING_AND_MASKED	00H	Number of processor cycles for which interrupts are disabled and interrupts are pending.	
Branches	C4H	BR_INST_RETIRED	00H	Number of branch instructions retired.	
	C5H	BR_MISS_PRED_RETIRED	00H	Number of mispredicted branches retired.	
	C9H	BR_TAKEN_RETIRED	00H	Number of taken branches retired.	
	CAH	BR_MISS_PRED_TAKEN_RET	00H	Number of taken mispredictions branches retired.	
	E0H	BR_INST_DECODED	00H	Number of branch instructions decoded.	
	E2H	BTB_MISSES	00H	Number of branches for which the BTB did not produce a prediction.	
	E4H	BR_BOGUS	00H	Number of bogus branches.	
	E6H	BACLEARs	00H	Number of times BACLEAR is asserted. This is the number of times that a static branch prediction was made, in which the branch decoder decided to make a branch prediction because the BTB did not.	

**Table 19-25. Events That Can Be Counted with the P6 Family Performance-Monitoring Counters (Contd.)**

Unit	Event Num.	Mnemonic Event Name	Unit Mask	Description	Comments
Stalls	A2H	RESOURCE_STALLS	00H	<p>Incremented by 1 during every cycle for which there is a resource related stall.</p> <p>Includes register renaming buffer entries, memory buffer entries.</p> <p>Does not include stalls due to bus queue full, too many cache misses, etc.</p> <p>In addition to resource related stalls, this event counts some other events.</p> <p>Includes stalls arising during branch misprediction recovery, such as if retirement of the mispredicted branch is delayed and stalls arising while store buffer is draining from synchronizing operations.</p>	
	D2H	PARTIAL_RAT_STALLS	00H	<p>Number of cycles or events for partial stalls. This includes flag partial stalls.</p>	
Segment Register Loads	06H	SEGMENT_REG_LOADS	00H	<p>Number of segment register loads.</p>	
Clocks	79H	CPU_CLK_UNHALTED	00H	<p>Number of cycles during which the processor is not halted.</p>	

**Table 19-25. Events That Can Be Counted with the P6 Family Performance-Monitoring Counters (Contd.)**

Unit	Event Num.	Mnemonic Event Name	Unit Mask	Description	Comments
MMX Unit	B0H	MMX_INSTR_EXEC	00H	Number of MMX Instructions Executed.	Available in Intel Celeron, Pentium II and Pentium II Xeon processors only. Does not account for MOVQ and MOVD stores from register to memory.
	B1H	MMX_SAT_INSTR_EXEC	00H	Number of MMX Saturating Instructions Executed.	Available in Pentium II and Pentium III processors only.
	B2H	MMX_UOPS_EXEC	0FH	Number of MMX $\mu$ ops Executed.	Available in Pentium II and Pentium III processors only.
	B3H	MMX_INSTR_TYPE_EXEC	01H	MMX packed multiply instructions executed.	Available in Pentium II and Pentium III processors only.
			02H	MMX packed shift instructions executed.	
			04H	MMX pack operation instructions executed.	
			08H	MMX unpack operation instructions executed.	
			10H	MMX packed logical instructions executed.	
20H	MMX packed arithmetic instructions executed.				
CCH	FP_MMX_TRANS	00H	Transitions from MMX instruction to floating-point instructions.	Available in Pentium II and Pentium III processors only.	
		01H	Transitions from floating-point instructions to MMX instructions.		
CDH	MMX_ASSIST	00H	Number of MMX Assists (that is, the number of EMMS instructions executed).	Available in Pentium II and Pentium III processors only.	
CEH	MMX_INSTR_RET	00H	Number of MMX Instructions Retired.	Available in Pentium II processors only.	



**Table 19-25. Events That Can Be Counted with the P6 Family Performance-Monitoring Counters (Contd.)**

Unit	Event Num.	Mnemonic Event Name	Unit Mask	Description	Comments
Segment Register Renaming	D4H	SEG_RENAME_STALLS		Number of Segment Register Renaming Stalls:	Available in Pentium II and Pentium III processors only.
			02H	Segment register ES	
			04H	Segment register DS	
			08H	Segment register FS	
			0FH	Segment register FS	
				Segment registers ES + DS + FS + GS	
	D5H	SEG_REG_RENAMES		Number of Segment Register Renames:	Available in Pentium II and Pentium III processors only.
			01H	Segment register ES	
			02H	Segment register DS	
			04H	Segment register FS	
			08H	Segment register FS	
			0FH	Segment registers ES + DS + FS + GS	
	D6H	RET_SEG_RENAMES	00H	Number of segment register rename events retired.	Available in Pentium II and Pentium III processors only.

**NOTES:**

1. Several L2 cache events, where noted, can be further qualified using the Unit Mask (UMSK) field in the PerfEvtSel0 and PerfEvtSel1 registers. The lower 4 bits of the Unit Mask field are used in conjunction with L2 events to indicate the cache state or cache states involved.

The P6 family processors identify cache states using the "MESI" protocol and consequently each bit in the Unit Mask field represents one of the four states: UMSK[3] = M (8H) state, UMSK[2] = E (4H) state, UMSK[1] = S (2H) state, and UMSK[0] = I (1H) state. UMSK[3:0] = MESI" (FH) should be used to collect data for all states; UMSK = 0H, for the applicable events, will result in nothing being counted.

2. All of the external bus logic (EBL) events, except where noted, can be further qualified using the Unit Mask (UMSK) field in the PerfEvtSel0 and PerfEvtSel1 registers.

Bit 5 of the UMSK field is used in conjunction with the EBL events to indicate whether the processor should count transactions that are self-generated (UMSK[5] = 0) or transactions that result from any processor on the bus (UMSK[5] = 1).

3. L2 cache locks, so it is possible to have a zero count.

## 19.13 PENTIUM PROCESSOR PERFORMANCE-MONITORING EVENTS

Table 19-26 lists the events that can be counted with the performance-monitoring counters for the Pentium processor. The Event Number column gives the hexadecimal code that identifies the event and that is entered in the ES0 or ES1 (event select) fields of the CESR MSR. The Mnemonic Event Name column gives the name of the event, and the Description and Comments columns give detailed descriptions of the events. Most events can be counted with either counter 0 or counter 1; however, some events can only be counted with only counter 0 or only counter 1 (as noted).

### NOTE

The events in the table that are shaded are implemented only in the Pentium processor with MMX technology.

**Table 19-26. Events That Can Be Counted with Pentium Processor Performance-Monitoring Counters**

Event Num.	Mnemonic Event Name	Description	Comments
00H	DATA_READ	Number of memory data reads (internal data cache hit and miss combined).	Split cycle reads are counted individually. Data Memory Reads that are part of TLB miss processing are not included. These events may occur at a maximum of two per clock. I/O is not included.
01H	DATA_WRITE	Number of memory data writes (internal data cache hit and miss combined); I/O not included.	Split cycle writes are counted individually. These events may occur at a maximum of two per clock. I/O is not included.
0H2	DATA_TLB_MISS	Number of misses to the data cache translation look-aside buffer.	

**Table 19-26. Events That Can Be Counted with Pentium Processor Performance-Monitoring Counters (Contd.)**

Event Num.	Mnemonic Event Name	Description	Comments
03H	DATA_READ_MISS	Number of memory read accesses that miss the internal data cache whether or not the access is cacheable or noncacheable.	Additional reads to the same cache line after the first BRDY# of the burst line fill is returned but before the final (fourth) BRDY# has been returned, will not cause the counter to be incremented additional times. Data accesses that are part of TLB miss processing are not included. Accesses directed to I/O space are not included.
04H	DATA_WRITE_MISS	Number of memory write accesses that miss the internal data cache whether or not the access is cacheable or noncacheable.	Data accesses that are part of TLB miss processing are not included. Accesses directed to I/O space are not included.
05H	WRITE_HIT_TO_M-OR-E-STATE_LINES	Number of write hits to exclusive or modified lines in the data cache.	These are the writes that may be held up if EWBE# is inactive. These events may occur a maximum of two per clock.
06H	DATA_CACHE_LINES_WRITTEN_BACK	Number of dirty lines (all) that are written back, regardless of the cause.	Replacements and internal and external snoops can all cause writeback and are counted.
07H	EXTERNAL_SNOOPS	Number of accepted external snoops whether they hit in the code cache or data cache or neither.	Assertions of EADS# outside of the sampling interval are not counted, and no internal snoops are counted.
08H	EXTERNAL_DATA_CACHE_SNOOP_HITS	Number of external snoops to the data cache.	Snoop hits to a valid line in either the data cache, the data line fill buffer, or one of the write back buffers are all counted as hits.
09H	MEMORY_ACCESSES_IN_BOTH_PIPES	Number of data memory reads or writes that are paired in both pipes of the pipeline.	These accesses are not necessarily run in parallel due to cache misses, bank conflicts, etc.
0AH	BANK_CONFLICTS	Number of actual bank conflicts.	

**Table 19-26. Events That Can Be Counted with Pentium Processor Performance-Monitoring Counters (Contd.)**

Event Num.	Mnemonic Event Name	Description	Comments
0BH	MISALIGNED DATA MEMORY OR I/O REFERENCES	Number of memory or I/O reads or writes that are misaligned.	A 2- or 4-byte access is misaligned when it crosses a 4-byte boundary; an 8-byte access is misaligned when it crosses an 8-byte boundary. Ten byte accesses are treated as two separate accesses of 8 and 2 bytes each.
0CH	CODE READ	Number of instruction reads; whether the read is cacheable or noncacheable.	Individual 8-byte noncacheable instruction reads are counted.
0DH	CODE TLB MISS	Number of instruction reads that miss the code TLB whether the read is cacheable or noncacheable.	Individual 8-byte noncacheable instruction reads are counted.
0EH	CODE CACHE MISS	Number of instruction reads that miss the internal code cache; whether the read is cacheable or noncacheable.	Individual 8-byte noncacheable instruction reads are counted.
0FH	ANY SEGMENT REGISTER LOADED	Number of writes into any segment register in real or protected mode including the LDTR, GDTR, IDTR, and TR.	Segment loads are caused by explicit segment register load instructions, far control transfers, and task switches. Far control transfers and task switches causing a privilege level change will signal this event twice. Interrupts and exceptions may initiate a far control transfer.
10H	Reserved		
11H	Reserved		

**Table 19-26. Events That Can Be Counted with Pentium Processor Performance-Monitoring Counters (Contd.)**

Event Num.	Mnemonic Event Name	Description	Comments
12H	Branches	Number of taken and not taken branches, including: conditional branches, jumps, calls, returns, software interrupts, and interrupt returns.	Also counted as taken branches are serializing instructions, VERR and VERW instructions, some segment descriptor loads, hardware interrupts (including FLUSH#), and programmatic exceptions that invoke a trap or fault handler. The pipe is not necessarily flushed.  The number of branches actually executed is measured, not the number of predicted branches.
13H	BTB_HITS	Number of BTB hits that occur.	Hits are counted only for those instructions that are actually executed.
14H	TAKEN_BRANCH_OR_BTBIT	Number of taken branches or BTB hits that occur.	This event type is a logical OR of taken branches and BTB hits. It represents an event that may cause a hit in the BTB. Specifically, it is either a candidate for a space in the BTB or it is already in the BTB.
15H	PIPELINE FLUSHES	Number of pipeline flushes that occur  Pipeline flushes are caused by BTB misses on taken branches, mispredictions, exceptions, interrupts, and some segment descriptor loads.	The counter will not be incremented for serializing instructions (serializing instructions cause the prefetch queue to be flushed but will not trigger the Pipeline Flushed event counter) and software interrupts (software interrupts do not flush the pipeline).

**Table 19-26. Events That Can Be Counted with Pentium Processor Performance-Monitoring Counters (Contd.)**

Event Num.	Mnemonic Event Name	Description	Comments
16H	INSTRUCTIONS_EXECUTED	Number of instructions executed (up to two per clock).	<p>Invocations of a fault handler are considered instructions. All hardware and software interrupts and exceptions will also cause the count to be incremented. Repeat prefixed string instructions will only increment this counter once despite the fact that the repeat loop executes the same instruction multiple times until the loop criteria is satisfied.</p> <p>This applies to all the Repeat string instruction prefixes (i.e., REP, REPE, REPZ, REPNE, and REPNZ). This counter will also only increment once per each HLT instruction executed regardless of how many cycles the processor remains in the HALT state.</p>
17H	INSTRUCTIONS_EXECUTED_V PIPE	<p>Number of instructions executed in the V_pipe.</p> <p>The event indicates the number of instructions that were paired.</p>	This event is the same as the 16H event except it only counts the number of instructions actually executed in the V-pipe.
18H	BUS_CYCLE_DURATION	<p>Number of clocks while a bus cycle is in progress.</p> <p>This event measures bus use.</p>	The count includes HLDA, AHOLD, and BOFF# clocks.
19H	WRITE_BUFFER_FULL_STALL_DURATION	Number of clocks while the pipeline is stalled due to full write buffers.	Full write buffers stall data memory read misses, data memory write misses, and data memory write hits to S-state lines. Stalls on I/O accesses are not included.
1AH	WAITING_FOR_DATA_MEMORY_READ_STALL_DURATION	Number of clocks while the pipeline is stalled while waiting for data memory reads.	Data TLB Miss processing is also included in the count. The pipeline stalls while a data memory read is in progress including attempts to read that are not bypassed while a line is being filled.

**Table 19-26. Events That Can Be Counted with Pentium Processor Performance-Monitoring Counters (Contd.)**

Event Num.	Mnemonic Event Name	Description	Comments
1BH	STALL ON WRITE TO AN E- OR M-STATE LINE	Number of stalls on writes to E- or M-state lines.	
1CH	LOCKED BUS CYCLE	Number of locked bus cycles that occur as the result of the LOCK prefix or LOCK instruction, page-table updates, and descriptor table updates.	Only the read portion of the locked read-modify-write is counted. Split locked cycles (SCYC active) count as two separate accesses. Cycles restarted due to BOFF# are not re-counted.
1DH	I/O READ OR WRITE CYCLE	Number of bus cycles directed to I/O space.	Misaligned I/O accesses will generate two bus cycles. Bus cycles restarted due to BOFF# are not re-counted.
1EH	NONCACHEABLE_MEMORY_READS	Number of noncacheable instruction or data memory read bus cycles. The count includes read cycles caused by TLB misses, but does not include read cycles to I/O space.	Cycles restarted due to BOFF# are not re-counted.
1FH	PIPELINE_AGI_STALLS	Number of address generation interlock (AGI) stalls. An AGI occurring in both the U- and V- pipelines in the same clock signals this event twice.	An AGI occurs when the instruction in the execute stage of either of U- or V-pipelines is writing to either the index or base address register of an instruction in the D2 (address generation) stage of either the U- or V- pipelines.
20H	Reserved		
21H	Reserved		

**Table 19-26. Events That Can Be Counted with Pentium Processor Performance-Monitoring Counters (Contd.)**

Event Num.	Mnemonic Event Name	Description	Comments
22H	FLOPS	Number of floating-point operations that occur.	<p>Number of floating-point adds, subtracts, multiplies, divides, remainders, and square roots are counted. The transcendental instructions consist of multiple adds and multiplies and will signal this event multiple times. Instructions generating the divide-by-zero, negative square root, special operand, or stack exceptions will not be counted.</p> <p>Instructions generating all other floating-point exceptions will be counted. The integer multiply instructions and other instructions which use the x87 FPU will be counted.</p>
23H	BREAKPOINT MATCH ON DR0 REGISTER	Number of matches on register DR0 breakpoint.	<p>The counters is incremented regardless if the breakpoints are enabled or not. However, if breakpoints are not enabled, code breakpoint matches will not be checked for instructions executed in the V-pipe and will not cause this counter to be incremented. (They are checked on instruction executed in the U-pipe only when breakpoints are not enabled.)</p> <p>These events correspond to the signals driven on the BP[3:0] pins. Refer to Chapter 17, "Debugging, Branch Profiling, and Time-Stamp Counter" for more information.</p>
24H	BREAKPOINT MATCH ON DR1 REGISTER	Number of matches on register DR1 breakpoint.	See comment for 23H event.
25H	BREAKPOINT MATCH ON DR2 REGISTER	Number of matches on register DR2 breakpoint.	See comment for 23H event.



**Table 19-26. Events That Can Be Counted with Pentium Processor Performance-Monitoring Counters (Contd.)**

Event Num.	Mnemonic Event Name	Description	Comments
26H	BREAKPOINT MATCH ON DR3 REGISTER	Number of matches on register DR3 breakpoint.	See comment for 23H event.
27H	HARDWARE INTERRUPTS	Number of taken INTR and NMI interrupts.	
28H	DATA_READ_OR_WRITE	Number of memory data reads and/or writes (internal data cache hit and miss combined).	Split cycle reads and writes are counted individually. Data Memory Reads that are part of TLB miss processing are not included. These events may occur at a maximum of two per clock. I/O is not included.
29H	DATA_READ_MISS OR_WRITE MISS	Number of memory read and/or write accesses that miss the internal data cache, whether or not the access is cacheable or noncacheable.	Additional reads to the same cache line after the first BRDY# of the burst line fill is returned but before the final (fourth) BRDY# has been returned, will not cause the counter to be incremented additional times. Data accesses that are part of TLB miss processing are not included. Accesses directed to I/O space are not included.
2AH	BUS_OWNERSHIP_LATENCY (Counter 0)	The time from LRM bus ownership request to bus ownership granted (that is, the time from the earlier of a PBREQ (0), PHITM# or HITM# assertion to a PBGNT assertion)	The ratio of the 2AH events counted on counter 0 and counter 1 is the average stall time due to bus ownership conflict.
2AH	BUS_OWNERSHIP_TRANSFERS (Counter 1)	The number of buss ownership transfers (that is, the number of PBREQ (0) assertions)	The ratio of the 2AH events counted on counter 0 and counter 1 is the average stall time due to bus ownership conflict.
2BH	MMX_INSTRUCTIONS_EXECUTED_U-PIPE (Counter 0)	Number of MMX instructions executed in the U-pipe	

**Table 19-26. Events That Can Be Counted with Pentium Processor Performance-Monitoring Counters (Contd.)**

Event Num.	Mnemonic Event Name	Description	Comments
2BH	MMX_INSTRUCTIONS_EXECUTED_V-PIPE (Counter 1)	Number of MMX instructions executed in the V-pipe	
2CH	CACHE_M-STATE_LINE_SHARING (Counter 0)	Number of times a processor identified a hit to a modified line due to a memory access in the other processor (PHITM (0))	If the average memory latencies of the system are known, this event enables the user to count the Write Backs on PHITM(0) penalty and the Latency on Hit Modified(I) penalty.
2CH	CACHE_LINE_SHARING (Counter 1)	Number of shared data lines in the L1 cache (PHIT (0))	
2DH	EMMS_INSTRUCTIONS_EXECUTED (Counter 0)	Number of EMMS instructions executed	
2DH	TRANSITIONS_BETWEEN_MMX_AND_FP_INSTRUCTIONS (Counter 1)	Number of transitions between MMX and floating-point instructions or vice versa  An even count indicates the processor is in MMX state. an odd count indicates it is in FP state.	This event counts the first floating-point instruction following an MMX instruction or first MMX instruction following a floating-point instruction.  The count may be used to estimate the penalty in transitions between floating-point state and MMX state.
2EH	BUS_UTILIZATION_DUE_TO_PROCESSOR_ACTIVITY (Counter 0)	Number of clocks the bus is busy due to the processor's own activity (the bus activity that is caused by the processor)	
2EH	WRITES_TO_NONCACHEABLE_MEMORY (Counter 1)	Number of write accesses to noncacheable memory	The count includes write cycles caused by TLB misses and I/O write cycles.  Cycles restarted due to BOFF# are not re-counted.

**Table 19-26. Events That Can Be Counted with Pentium Processor Performance-Monitoring Counters (Contd.)**

Event Num.	Mnemonic Event Name	Description	Comments
2FH	SATURATING_MMX_INSTRUCTIONS_EXECUTED (Counter 0)	Number of saturating MMX instructions executed, independently of whether they actually saturated.	
2FH	SATURATIONS_PERFORMED (Counter 1)	Number of MMX instructions that used saturating arithmetic when at least one of its results actually saturated	If an MMX instruction operating on 4 doublewords saturated in three out of the four results, the counter will be incremented by one only.
30H	NUMBER_OF_CYCLES_NOT_IN_HALT_STATE (Counter 0)	Number of cycles the processor is not idle due to HLT instruction	This event will enable the user to calculate "net CPI". Note that during the time that the processor is executing the HLT instruction, the Time-Stamp Counter is not disabled. Since this event is controlled by the Counter Controls CCO, CC1 it can be used to calculate the CPI at CPL=3, which the TSC cannot provide.
30H	DATA_CACHE_TLB_MISS_STALL_DURATION (Counter 1)	Number of clocks the pipeline is stalled due to a data cache translation look-aside buffer (TLB) miss	
31H	MMX_INSTRUCTION_DATA_READS (Counter 0)	Number of MMX instruction data reads	
31H	MMX_INSTRUCTION_DATA_READ_MISSES (Counter 1)	Number of MMX instruction data read misses	
32H	FLOATING_POINT_STALLS_DURATION (Counter 0)	Number of clocks while pipe is stalled due to a floating-point freeze	

**Table 19-26. Events That Can Be Counted with Pentium Processor Performance-Monitoring Counters (Contd.)**

<b>Event Num.</b>	<b>Mnemonic Event Name</b>	<b>Description</b>	<b>Comments</b>
32H	TAKEN_BRANCHES (Counter 1)	Number of taken branches	
33H	D1_STARVATION_ AND_FIFO_IS_EMPTY (Counter 0)	Number of times D1 stage cannot issue ANY instructions since the FIFO buffer is empty	The D1 stage can issue 0, 1, or 2 instructions per clock if those are available in an instructions FIFO buffer.
33H	D1_STARVATION_ AND_ONLY_ONE_INSTRUCTION_IN_FIFO (Counter 1)	Number of times the D1 stage issues a single instruction (since the FIFO buffer had just one instruction ready)	The D1 stage can issue 0, 1, or 2 instructions per clock if those are available in an instructions FIFO buffer.  When combined with the previously defined events, Instruction Executed (16H) and Instruction Executed in the V-pipe (17H), this event enables the user to calculate the numbers of time pairing rules prevented issuing of two instructions.
34H	MMX_INSTRUCTION_DATA_WRITES (Counter 0)	Number of data writes caused by MMX instructions	
34H	MMX_INSTRUCTION_DATA_WRITE_MISSES (Counter 1)	Number of data write misses caused by MMX instructions	

**Table 19-26. Events That Can Be Counted with Pentium Processor Performance-Monitoring Counters (Contd.)**

Event Num.	Mnemonic Event Name	Description	Comments
35H	PIPELINE_FLUSHES_DUE_TO_WRONG_BRANCH_PREDICTIONS (Counter 0)	Number of pipeline flushes due to wrong branch predictions resolved in either the E-stage or the WB-stage	The count includes any pipeline flush due to a branch that the pipeline did not follow correctly. It includes cases where a branch was not in the BTB, cases where a branch was in the BTB but was mispredicted, and cases where a branch was correctly predicted but to the wrong address. Branches are resolved in either the Execute stage (E-stage) or the Writeback stage (WB-stage). In the later case, the misprediction penalty is larger by one clock. The difference between the 35H event count in counter 0 and counter 1 is the number of E-stage resolved branches.
35H	PIPELINE_FLUSHES_DUE_TO_WRONG_BRANCH_PREDICTIONS_RESOLVED_IN_WB-STAGE (Counter 1)	Number of pipeline flushes due to wrong branch predictions resolved in the WB-stage	See note for event 35H (Counter 0).
36H	MISALIGNED_DATA_MEMORY_REFERENCE_ON_MMX_INSTRUCTIONS (Counter 0)	Number of misaligned data memory references when executing MMX instructions	
36H	PIPELINE_ISTALL_FOR_MMX_INSTRUCTION_DATA_MEMORY_READS (Counter 1)	Number clocks during pipeline stalls caused by waits form MMX instruction data memory reads	T3:

**Table 19-26. Events That Can Be Counted with Pentium Processor Performance-Monitoring Counters (Contd.)**

Event Num.	Mnemonic Event Name	Description	Comments
37H	MISPREDICTED_OR_UNPREDICTED_RETURNS (Counter 1)	Number of returns predicted incorrectly or not predicted at all	The count is the difference between the total number of executed returns and the number of returns that were correctly predicted. Only RET instructions are counted (for example, IRET instructions are not counted).
37H	PREDICTED_RETURNS (Counter 1)	Number of predicted returns (whether they are predicted correctly and incorrectly)	Only RET instructions are counted (for example, IRET instructions are not counted).
38H	MMX_MULTIPLY_UNIT_INTERLOCK (Counter 0)	Number of clocks the pipe is stalled since the destination of previous MMX multiply instruction is not ready yet	The counter will not be incremented if there is another cause for a stall. For each occurrence of a multiply interlock, this event will be counted twice (if the stalled instruction comes on the next clock after the multiply) or by once (if the stalled instruction comes two clocks after the multiply).
38H	MOVD/MOVQ_STORE_STALL_DUE_TO_PREVIOUS_MMX_OPERATION (Counter 1)	Number of clocks a MOVD/MOVQ instruction store is stalled in D2 stage due to a previous MMX operation with a destination to be used in the store instruction.	
39H	RETURNS (Counter 0)	Number of returns executed.	Only RET instructions are counted; IRET instructions are not counted. Any exception taken on a RET instruction and any interrupt recognized by the processor on the instruction boundary prior to the execution of the RET instruction will also cause this counter to be incremented.
39H	Reserved		

**Table 19-26. Events That Can Be Counted with Pentium Processor Performance-Monitoring Counters (Contd.)**

Event Num.	Mnemonic Event Name	Description	Comments
3AH	BTB_FALSE_ENTRIES (Counter 0)	Number of false entries in the Branch Target Buffer	False entries are causes for misprediction other than a wrong prediction.
3AH	BTB_MISS_PREDICTION_ON_NOT-TAKEN_BRANCH (Counter 1)	Number of times the BTB predicted a not-taken branch as taken	
3BH	FULL_WRITE_BUFFER_STALL_DURATION_WHILE_EXECUTING_MMX_INSTRUCTIONS (Counter 0)	Number of clocks while the pipeline is stalled due to full write buffers while executing MMX instructions	
3BH	STALL_ON_MMX_INSTRUCTION_WRITE_TO_E-OR_M-STATE_LINE (Counter 1)	Number of clocks during stalls on MMX instructions writing to E- or M-state lines	

## CHAPTER 20

# 8086 EMULATION

---

IA-32 processors (beginning with the Intel386 processor) provide two ways to execute new or legacy programs that are assembled and/or compiled to run on an Intel 8086 processor:

- Real-address mode.
- Virtual-8086 mode.

Figure 2-3 shows the relationship of these operating modes to protected mode and system management mode (SMM).

When the processor is powered up or reset, it is placed in the real-address mode. This operating mode almost exactly duplicates the execution environment of the Intel 8086 processor, with some extensions. Virtually any program assembled and/or compiled to run on an Intel 8086 processor will run on an IA-32 processor in this mode.

When running in protected mode, the processor can be switched to virtual-8086 mode to run 8086 programs. This mode also duplicates the execution environment of the Intel 8086 processor, with extensions. In virtual-8086 mode, an 8086 program runs as a separate protected-mode task. Legacy 8086 programs are thus able to run under an operating system (such as Microsoft Windows\*) that takes advantage of protected mode and to use protected-mode facilities, such as the protected-mode interrupt- and exception-handling facilities. Protected-mode multitasking permits multiple virtual-8086 mode tasks (with each task running a separate 8086 program) to be run on the processor along with other non-virtual-8086 mode tasks.

This section describes both the basic real-address mode execution environment and the virtual-8086-mode execution environment, available on the IA-32 processors beginning with the Intel386 processor.

## 20.1 REAL-ADDRESS MODE

The IA-32 architecture's real-address mode runs programs written for the Intel 8086, Intel 8088, Intel 80186, and Intel 80188 processors, or for the real-address mode of the Intel 286, Intel386, Intel486, Pentium, P6 family, Pentium 4, and Intel Xeon processors.

The execution environment of the processor in real-address mode is designed to duplicate the execution environment of the Intel 8086 processor. To an 8086 program, a processor operating in real-address mode behaves like a high-speed 8086 processor. The principal features of this architecture are defined in Chapter 3, "Basic Execution Environment", of the *Intel® 64 and IA-32 Architectures Software Developer's Manual, Volume 1*.



The following is a summary of the core features of the real-address mode execution environment as would be seen by a program written for the 8086:

- The processor supports a nominal 1-MByte physical address space (see Section 20.1.1, “Address Translation in Real-Address Mode”, for specific details). This address space is divided into segments, each of which can be up to 64 KBytes in length. The base of a segment is specified with a 16-bit segment selector, which is zero extended to form a 20-bit offset from address 0 in the address space. An operand within a segment is addressed with a 16-bit offset from the base of the segment. A physical address is thus formed by adding the offset to the 20-bit segment base (see Section 20.1.1, “Address Translation in Real-Address Mode”).
- All operands in “native 8086 code” are 8-bit or 16-bit values. (Operand size override prefixes can be used to access 32-bit operands.)
- Eight 16-bit general-purpose registers are provided: AX, BX, CX, DX, SP, BP, SI, and DI. The extended 32-bit registers (EAX, EBX, ECX, EDX, ESP, EBP, ESI, and EDI) are accessible to programs that explicitly perform a size override operation.
- Four segment registers are provided: CS, DS, SS, and ES. (The FS and GS registers are accessible to programs that explicitly access them.) The CS register contains the segment selector for the code segment; the DS and ES registers contain segment selectors for data segments; and the SS register contains the segment selector for the stack segment.
- The 8086 16-bit instruction pointer (IP) is mapped to the lower 16-bits of the EIP register. Note this register is a 32-bit register and unintentional address wrapping may occur.
- The 16-bit FLAGS register contains status and control flags. (This register is mapped to the 16 least significant bits of the 32-bit EFLAGS register.)
- All of the Intel 8086 instructions are supported (see Section 20.1.3, “Instructions Supported in Real-Address Mode”).
- A single, 16-bit-wide stack is provided for handling procedure calls and invocations of interrupt and exception handlers. This stack is contained in the stack segment identified with the SS register. The SP (stack pointer) register contains an offset into the stack segment. The stack grows down (toward lower segment offsets) from the stack pointer. The BP (base pointer) register also contains an offset into the stack segment that can be used as a pointer to a parameter list. When a CALL instruction is executed, the processor pushes the current instruction pointer (the 16 least-significant bits of the EIP register and, on far calls, the current value of the CS register) onto the stack. On a return, initiated with a RET instruction, the processor pops the saved instruction pointer from the stack into the EIP register (and CS register on far returns). When an implicit call to an interrupt or exception handler is executed, the processor pushes the EIP, CS, and EFLAGS (low-order 16-bits only) registers onto the stack. On a return from an interrupt or exception handler, initiated with an IRET instruction, the processor pops the saved instruction pointer and EFLAGS image from the stack into the EIP, CS, and EFLAGS registers.

- A single interrupt table, called the “interrupt vector table” or “interrupt table,” is provided for handling interrupts and exceptions (see Figure 20-2). The interrupt table (which has 4-byte entries) takes the place of the interrupt descriptor table (IDT, with 8-byte entries) used when handling protected-mode interrupts and exceptions. Interrupt and exception vector numbers provide an index to entries in the interrupt table. Each entry provides a pointer (called a “vector”) to an interrupt- or exception-handling procedure. See Section 20.1.4, “Interrupt and Exception Handling”, for more details. It is possible for software to relocate the IDT by means of the LIDT instruction on IA-32 processors beginning with the Intel386 processor.
- The x87 FPU is active and available to execute x87 FPU instructions in real-address mode. Programs written to run on the Intel 8087 and Intel 287 math coprocessors can be run in real-address mode without modification.

The following extensions to the Intel 8086 execution environment are available in the IA-32 architecture’s real-address mode. If backwards compatibility to Intel 286 and Intel 8086 processors is required, these features should not be used in new programs written to run in real-address mode.

- Two additional segment registers (FS and GS) are available.
- Many of the integer and system instructions that have been added to later IA-32 processors can be executed in real-address mode (see Section 20.1.3, “Instructions Supported in Real-Address Mode”).
- The 32-bit operand prefix can be used in real-address mode programs to execute the 32-bit forms of instructions. This prefix also allows real-address mode programs to use the processor’s 32-bit general-purpose registers.
- The 32-bit address prefix can be used in real-address mode programs, allowing 32-bit offsets.

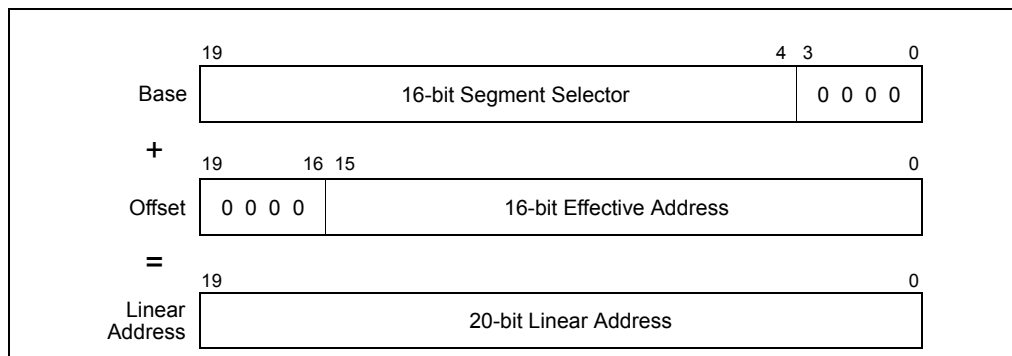
The following sections describe address formation, registers, available instructions, and interrupt and exception handling in real-address mode. For information on I/O in real-address mode, see Chapter 13, “Input/Output”, of the *Intel® 64 and IA-32 Architectures Software Developer’s Manual, Volume 1*.

## 20.1.1 Address Translation in Real-Address Mode

In real-address mode, the processor does not interpret segment selectors as indexes into a descriptor table; instead, it uses them directly to form linear addresses as the 8086 processor does. It shifts the segment selector left by 4 bits to form a 20-bit base address (see Figure 20-1). The offset into a segment is added to the base address to create a linear address that maps directly to the physical address space.

When using 8086-style address translation, it is possible to specify addresses larger than 1 MByte. For example, with a segment selector value of FFFFH and an offset of FFFFH, the linear (and physical) address would be 10FFEFH (1 megabyte plus 64 KBytes). The 8086 processor, which can form addresses only up to 20 bits long, truncates the high-order bit, thereby “wrapping” this address to FFEFH. When operating

in real-address mode, however, the processor does not truncate such an address and uses it as a physical address. (Note, however, that for IA-32 processors beginning with the Intel486 processor, the A20M# signal can be used in real-address mode to mask address line A20, thereby mimicking the 20-bit wrap-around behavior of the 8086 processor.) Care should be taken to ensure that A20M# based address wrapping is handled correctly in multiprocessor based system.



**Figure 20-1. Real-Address Mode Address Translation**

The IA-32 processors beginning with the Intel386 processor can generate 32-bit offsets using an address override prefix; however, in real-address mode, the value of a 32-bit offset may not exceed FFFFH without causing an exception.

For full compatibility with Intel 286 real-address mode, pseudo-protection faults (interrupt 12 or 13) occur if a 32-bit offset is generated outside the range 0 through FFFFH.

### 20.1.2 Registers Supported in Real-Address Mode

The register set available in real-address mode includes all the registers defined for the 8086 processor plus the new registers introduced in later IA-32 processors, such as the FS and GS segment registers, the debug registers, the control registers, and the floating-point unit registers. The 32-bit operand prefix allows a real-address mode program to use the 32-bit general-purpose registers (EAX, EBX, ECX, EDX, ESP, EBP, ESI, and EDI).

### 20.1.3 Instructions Supported in Real-Address Mode

The following instructions make up the core instruction set for the 8086 processor. If backwards compatibility to the Intel 286 and Intel 8086 processors is required, only these instructions should be used in a new program written to run in real-address mode.

- Move (MOV) instructions that move operands between general-purpose registers, segment registers, and between memory and general-purpose registers.
- The exchange (XCHG) instruction.
- Load segment register instructions LDS and LES.
- Arithmetic instructions ADD, ADC, SUB, SBB, MUL, IMUL, DIV, IDIV, INC, DEC, CMP, and NEG.
- Logical instructions AND, OR, XOR, and NOT.
- Decimal instructions DAA, DAS, AAA, AAS, AAM, and AAD.
- Stack instructions PUSH and POP (to general-purpose registers and segment registers).
- Type conversion instructions CWD, CDQ, CBW, and CWDE.
- Shift and rotate instructions SAL, SHL, SHR, SAR, ROL, ROR, RCL, and RCR.
- TEST instruction.
- Control instructions JMP, Jcc, CALL, RET, LOOP, LOOPE, and LOOPNE.
- Interrupt instructions INT *n*, INTO, and IRET.
- EFLAGS control instructions STC, CLC, CMC, CLD, STD, LAHF, SAHF, PUSHF, and POPF.
- I/O instructions IN, INS, OUT, and OUTS.
- Load effective address (LEA) instruction, and translate (XLATB) instruction.
- LOCK prefix.
- Repeat prefixes REP, REPE, REPZ, REPNE, and REPNZ.
- Processor halt (HLT) instruction.
- No operation (NOP) instruction.

The following instructions, added to later IA-32 processors (some in the Intel 286 processor and the remainder in the Intel386 processor), can be executed in real-address mode, if backwards compatibility to the Intel 8086 processor is not required.

- Move (MOV) instructions that operate on the control and debug registers.
- Load segment register instructions LSS, LFS, and LGS.
- Generalized multiply instructions and multiply immediate data.
- Shift and rotate by immediate counts.
- Stack instructions PUSHA, PUSHAD, POPA and POPAD, and PUSH immediate data.
- Move with sign extension instructions MOVSX and MOVZX.
- Long-displacement Jcc instructions.
- Exchange instructions CMPXCHG, CMPXCHG8B, and XADD.
- String instructions MOVS, CMPS, SCAS, LODS, and STOS.

- Bit test and bit scan instructions BT, BTS, BTR, BTC, BSF, and BSR; the byte-set-on condition instruction SETcc; and the byte swap (BSWAP) instruction.
- Double shift instructions SHLD and SHRD.
- EFLAGS control instructions PUSHF and POPF.
- ENTER and LEAVE control instructions.
- BOUND instruction.
- CPU identification (CPUID) instruction.
- System instructions CLTS, INVD, WINVD, INVLPG, LGDT, SGDT, LIDT, SIDT, LMSW, SMSW, RDMSR, WRMSR, RDTSC, and RDPMS.

Execution of any of the other IA-32 architecture instructions (not given in the previous two lists) in real-address mode result in an invalid-opcode exception (#UD) being generated.

### 20.1.4 Interrupt and Exception Handling

When operating in real-address mode, software must provide interrupt and exception-handling facilities that are separate from those provided in protected mode. Even during the early stages of processor initialization when the processor is still in real-address mode, elementary real-address mode interrupt and exception-handling facilities must be provided to insure reliable operation of the processor, or the initialization code must insure that no interrupts or exceptions will occur.

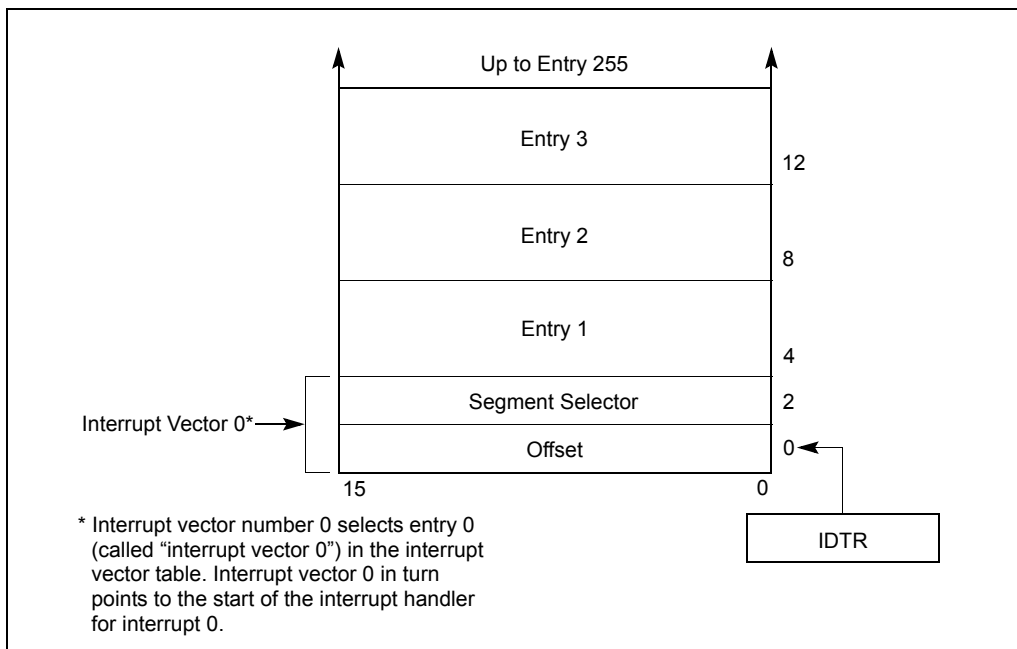
The IA-32 processors handle interrupts and exceptions in real-address mode similar to the way they handle them in protected mode. When a processor receives an interrupt or generates an exception, it uses the vector number of the interrupt or exception as an index into the interrupt table. (In protected mode, the interrupt table is called the **interrupt descriptor table (IDT)**, but in real-address mode, the table is usually called the **interrupt vector table**, or simply the **interrupt table**.) The entry in the interrupt vector table provides a pointer to an interrupt- or exception-handler procedure. (The pointer consists of a segment selector for a code segment and a 16-bit offset into the segment.) The processor performs the following actions to make an implicit call to the selected handler:

1. Pushes the current values of the CS and EIP registers onto the stack. (Only the 16 least-significant bits of the EIP register are pushed.)
2. Pushes the low-order 16 bits of the EFLAGS register onto the stack.
3. Clears the IF flag in the EFLAGS register to disable interrupts.
4. Clears the TF, RC, and AC flags, in the EFLAGS register.
5. Transfers program control to the location specified in the interrupt vector table.

An IRET instruction at the end of the handler procedure reverses these steps to return program control to the interrupted program. Exceptions do not return error codes in real-address mode.

The interrupt vector table is an array of 4-byte entries (see Figure 20-2). Each entry consists of a far pointer to a handler procedure, made up of a segment selector and an offset. The processor scales the interrupt or exception vector by 4 to obtain an offset into the interrupt table. Following reset, the base of the interrupt vector table is located at physical address 0 and its limit is set to 3FFH. In the Intel 8086 processor, the base address and limit of the interrupt vector table cannot be changed. In the later IA-32 processors, the base address and limit of the interrupt vector table are contained in the IDTR register and can be changed using the LIDT instruction.

(For backward compatibility to Intel 8086 processors, the default base address and limit of the interrupt vector table should not be changed.)



**Figure 20-2. Interrupt Vector Table in Real-Address Mode**

Table 20-1 shows the interrupt and exception vectors that can be generated in real-address mode and virtual-8086 mode, and in the Intel 8086 processor. See Chapter 6, "Interrupt and Exception Handling", for a description of the exception conditions.

## 20.2 VIRTUAL-8086 MODE

Virtual-8086 mode is actually a special type of a task that runs in protected mode. When the operating-system or executive switches to a virtual-8086-mode task, the processor emulates an Intel 8086 processor. The execution environment of the processor while in the 8086-emulation state is the same as is described in Section 20.1, "Real-Address Mode" for real-address mode, including the extensions. The major difference between the two modes is that in virtual-8086 mode the 8086 emulator uses some protected-mode services (such as the protected-mode interrupt and exception-handling and paging facilities).

As in real-address mode, any new or legacy program that has been assembled and/or compiled to run on an Intel 8086 processor will run in a virtual-8086-mode task. And several 8086 programs can be run as virtual-8086-mode tasks concurrently with normal protected-mode tasks, using the processor's multitasking facilities.

**Table 20-1. Real-Address Mode Exceptions and Interrupts**

Vector No.	Description	Real-Address Mode	Virtual-8086 Mode	Intel 8086 Processor
0	Divide Error (#DE)	Yes	Yes	Yes
1	Debug Exception (#DB)	Yes	Yes	No
2	NMI Interrupt	Yes	Yes	Yes
3	Breakpoint (#BP)	Yes	Yes	Yes
4	Overflow (#OF)	Yes	Yes	Yes
5	BOUND Range Exceeded (#BR)	Yes	Yes	Reserved
6	Invalid Opcode (#UD)	Yes	Yes	Reserved
7	Device Not Available (#NM)	Yes	Yes	Reserved
8	Double Fault (#DF)	Yes	Yes	Reserved
9	(Intel reserved. Do not use.)	Reserved	Reserved	Reserved
10	Invalid TSS (#TS)	Reserved	Yes	Reserved
11	Segment Not Present (#NP)	Reserved	Yes	Reserved
12	Stack Fault (#SS)	Yes	Yes	Reserved
13	General Protection (#GP)*	Yes	Yes	Reserved
14	Page Fault (#PF)	Reserved	Yes	Reserved
15	(Intel reserved. Do not use.)	Reserved	Reserved	Reserved
16	Floating-Point Error (#MF)	Yes	Yes	Reserved
17	Alignment Check (#AC)	Reserved	Yes	Reserved
18	Machine Check (#MC)	Yes	Yes	Reserved

**Table 20-1. Real-Address Mode Exceptions and Interrupts (Contd.)**

Vector No.	Description	Real-Address Mode	Virtual-8086 Mode	Intel 8086 Processor
19-31	(Intel reserved. Do not use.)	Reserved	Reserved	Reserved
32-255	User Defined Interrupts	Yes	Yes	Yes

**NOTE:**

\* In the real-address mode, vector 13 is the segment overrun exception. In protected and virtual-8086 modes, this exception covers all general-protection error conditions, including traps to the virtual-8086 monitor from virtual-8086 mode.

## 20.2.1 Enabling Virtual-8086 Mode

The processor runs in virtual-8086 mode when the VM (virtual machine) flag in the EFLAGS register is set. This flag can only be set when the processor switches to a new protected-mode task or resumes virtual-8086 mode via an IRET instruction.

System software cannot change the state of the VM flag directly in the EFLAGS register (for example, by using the POPFD instruction). Instead it changes the flag in the image of the EFLAGS register stored in the TSS or on the stack following a call to an interrupt- or exception-handler procedure. For example, software sets the VM flag in the EFLAGS image in the TSS when first creating a virtual-8086 task.

The processor tests the VM flag under three general conditions:

- When loading segment registers, to determine whether to use 8086-style address translation.
- When decoding instructions, to determine which instructions are not supported in virtual-8086 mode and which instructions are sensitive to IOPL.
- When checking privileged instructions, on page accesses, or when performing other permission checks. (Virtual-8086 mode always executes at CPL 3.)

## 20.2.2 Structure of a Virtual-8086 Task

A virtual-8086-mode task consists of the following items:

- A 32-bit TSS for the task.
- The 8086 program.
- A virtual-8086 monitor.
- 8086 operating-system services.

The TSS of the new task must be a 32-bit TSS, not a 16-bit TSS, because the 16-bit TSS does not load the most-significant word of the EFLAGS register, which contains the VM flag. All TSS's, stacks, data, and code used to handle exceptions when in virtual-8086 mode must also be 32-bit segments.



The processor enters virtual-8086 mode to run the 8086 program and returns to protected mode to run the virtual-8086 monitor.

The virtual-8086 monitor is a 32-bit protected-mode code module that runs at a CPL of 0. The monitor consists of initialization, interrupt- and exception-handling, and I/O emulation procedures that emulate a personal computer or other 8086-based platform. Typically, the monitor is either part of or closely associated with the protected-mode general-protection (#GP) exception handler, which also runs at a CPL of 0. As with any protected-mode code module, code-segment descriptors for the virtual-8086 monitor must exist in the GDT or in the task's LDT. The virtual-8086 monitor also may need data-segment descriptors so it can examine the IDT or other parts of the 8086 program in the first 1 MByte of the address space. The linear addresses above 10FFFEFH are available for the monitor, the operating system, and other system software.

The 8086 operating-system services consists of a kernel and/or operating-system procedures that the 8086 program makes calls to. These services can be implemented in either of the following two ways:

- They can be included in the 8086 program. This approach is desirable for either of the following reasons:
  - The 8086 program code modifies the 8086 operating-system services.
  - There is not sufficient development time to merge the 8086 operating-system services into main operating system or executive.
- They can be implemented or emulated in the virtual-8086 monitor. This approach is desirable for any of the following reasons:
  - The 8086 operating-system procedures can be more easily coordinated among several virtual-8086 tasks.
  - Memory can be saved by not duplicating 8086 operating-system procedure code for several virtual-8086 tasks.
  - The 8086 operating-system procedures can be easily emulated by calls to the main operating system or executive.

The approach chosen for implementing the 8086 operating-system services may result in different virtual-8086-mode tasks using different 8086 operating-system services.

### 20.2.3 Paging of Virtual-8086 Tasks

Even though a program running in virtual-8086 mode can use only 20-bit linear addresses, the processor converts these addresses into 32-bit linear addresses before mapping them to the physical address space. If paging is being used, the 8086 address space for a program running in virtual-8086 mode can be paged and located in a set of pages in physical address space. If paging is used, it is transparent to the program running in virtual-8086 mode just as it is for any task running on the processor.

Paging is not necessary for a single virtual-8086-mode task, but paging is useful or necessary in the following situations:

- When running multiple virtual-8086-mode tasks. Here, paging allows the lower 1 MByte of the linear address space for each virtual-8086-mode task to be mapped to a different physical address location.
- When emulating the 8086 address-wraparound that occurs at 1 MByte. When using 8086-style address translation, it is possible to specify addresses larger than 1 MByte. These addresses automatically wraparound in the Intel 8086 processor (see Section 20.1.1, "Address Translation in Real-Address Mode"). If any 8086 programs depend on address wraparound, the same effect can be achieved in a virtual-8086-mode task by mapping the linear addresses between 100000H and 110000H and linear addresses between 0 and 10000H to the same physical addresses.
- When sharing the 8086 operating-system services or ROM code that is common to several 8086 programs running as different 8086-mode tasks.
- When redirecting or trapping references to memory-mapped I/O devices.

## 20.2.4 Protection within a Virtual-8086 Task

Protection is not enforced between the segments of an 8086 program. Either of the following techniques can be used to protect the system software running in a virtual-8086-mode task from the 8086 program:

- Reserve the first 1 MByte plus 64 KBytes of each task's linear address space for the 8086 program. An 8086 processor task cannot generate addresses outside this range.
- Use the U/S flag of page-table entries to protect the virtual-8086 monitor and other system software in the virtual-8086 mode task space. When the processor is in virtual-8086 mode, the CPL is 3. Therefore, an 8086 processor program has only user privileges. If the pages of the virtual-8086 monitor have supervisor privilege, they cannot be accessed by the 8086 program.

## 20.2.5 Entering Virtual-8086 Mode

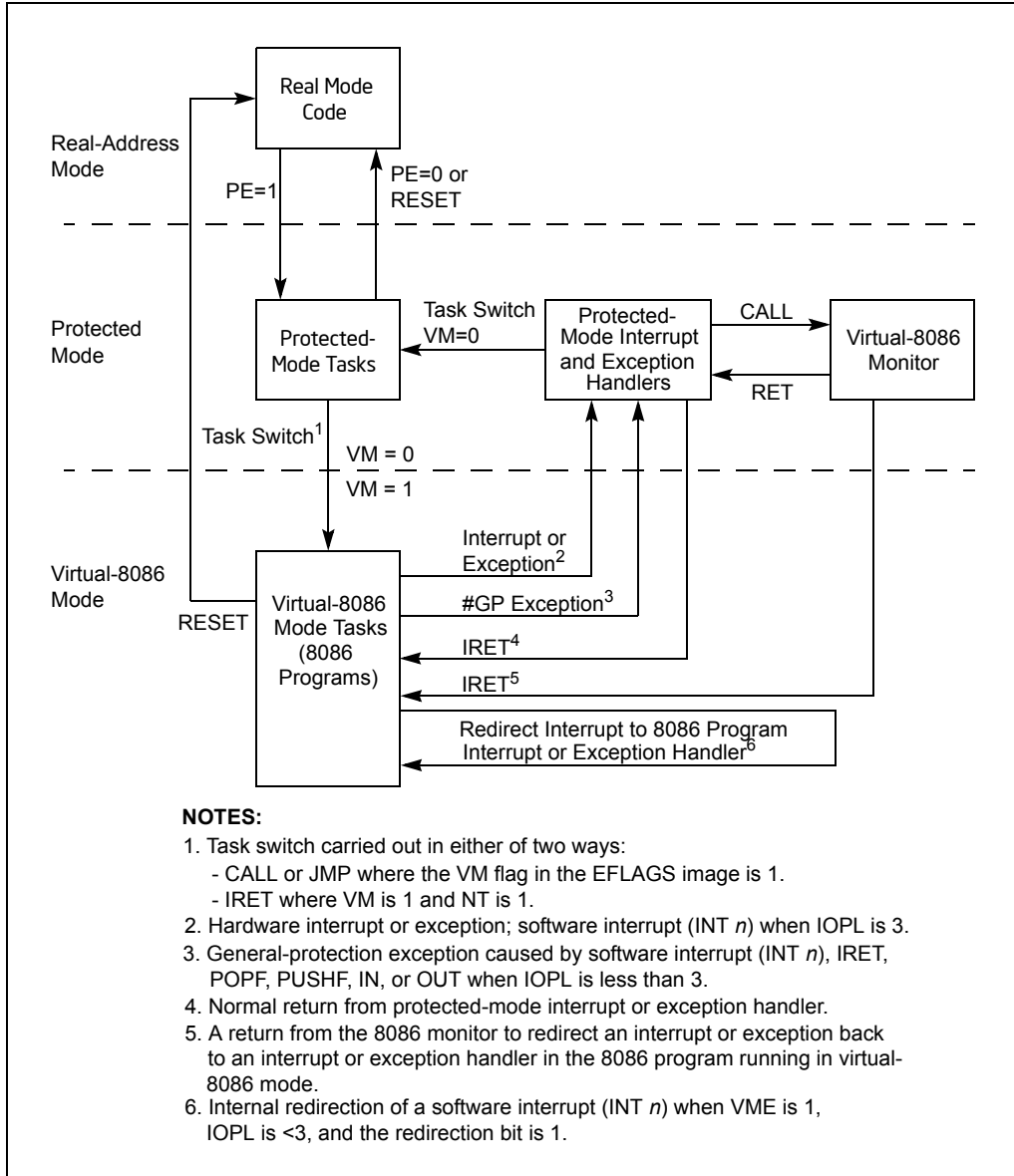
Figure 20-3 summarizes the methods of entering and leaving virtual-8086 mode. The processor switches to virtual-8086 mode in either of the following situations:

- Task switch when the VM flag is set to 1 in the EFLAGS register image stored in the TSS for the task. Here the task switch can be initiated in either of two ways:
  - A CALL or JMP instruction.
  - An IRET instruction, where the NT flag in the EFLAGS image is set to 1.
- Return from a protected-mode interrupt or exception handler when the VM flag is set to 1 in the EFLAGS register image on the stack.

## 8086 EMULATION

When a task switch is used to enter virtual-8086 mode, the TSS for the virtual-8086-mode task must be a 32-bit TSS. (If the new TSS is a 16-bit TSS, the upper word of the EFLAGS register is not in the TSS, causing the processor to clear the VM flag when it loads the EFLAGS register.) The processor updates the VM flag prior to loading the segment registers from their images in the new TSS. The new setting of the VM flag determines whether the processor interprets the contents of the segment registers as 8086-style segment selectors or protected-mode segment selectors. When the VM flag is set, the segment registers are loaded from the TSS, using 8086-style address translation to form base addresses.

See Section 20.3, "Interrupt and Exception Handling in Virtual-8086 Mode", for information on entering virtual-8086 mode on a return from an interrupt or exception handler.



**Figure 20-3. Entering and Leaving Virtual-8086 Mode**

## 20.2.6 Leaving Virtual-8086 Mode

The processor can leave the virtual-8086 mode only through an interrupt or exception. The following are situations where an interrupt or exception will lead to the processor leaving virtual-8086 mode (see Figure 20-3):

- The processor services a hardware interrupt generated to signal the suspension of execution of the virtual-8086 application. This hardware interrupt may be generated by a timer or other external mechanism. Upon receiving the hardware interrupt, the processor enters protected mode and switches to a protected-mode (or another virtual-8086 mode) task either through a task gate in the protected-mode IDT or through a trap or interrupt gate that points to a handler that initiates a task switch. A task switch from a virtual-8086 task to another task loads the EFLAGS register from the TSS of the new task. The value of the VM flag in the new EFLAGS determines if the new task executes in virtual-8086 mode or not.
- The processor services an exception caused by code executing the virtual-8086 task or services a hardware interrupt that “belongs to” the virtual-8086 task. Here, the processor enters protected mode and services the exception or hardware interrupt through the protected-mode IDT (normally through an interrupt or trap gate) and the protected-mode exception- and interrupt-handlers. The processor may handle the exception or interrupt within the context of the virtual 8086 task and return to virtual-8086 mode on a return from the handler procedure. The processor may also execute a task switch and handle the exception or interrupt in the context of another task.
- The processor services a software interrupt generated by code executing in the virtual-8086 task (such as a software interrupt to call a MS-DOS\* operating system routine). The processor provides several methods of handling these software interrupts, which are discussed in detail in Section 20.3.3, “Class 3—Software Interrupt Handling in Virtual-8086 Mode”. Most of them involve the processor entering protected mode, often by means of a general-protection (#GP) exception. In protected mode, the processor can send the interrupt to the virtual-8086 monitor for handling and/or redirect the interrupt back to the application program running in virtual-8086 mode task for handling.  
  
IA-32 processors that incorporate the virtual mode extension (enabled with the VME flag in control register CR4) are capable of redirecting software-generated interrupts back to the program’s interrupt handlers without leaving virtual-8086 mode. See Section 20.3.3.4, “Method 5: Software Interrupt Handling”, for more information on this mechanism.
- A hardware reset initiated by asserting the RESET or INIT pin is a special kind of interrupt. When a RESET or INIT is signaled while the processor is in virtual-8086 mode, the processor leaves virtual-8086 mode and enters real-address mode.
- Execution of the HLT instruction in virtual-8086 mode will cause a general-protection (GP#) fault, which the protected-mode handler generally sends to the virtual-8086 monitor. The virtual-8086 monitor then determines the correct

execution sequence after verifying that it was entered as a result of a HLT execution.

See Section 20.3, “Interrupt and Exception Handling in Virtual-8086 Mode”, for information on leaving virtual-8086 mode to handle an interrupt or exception generated in virtual-8086 mode.

## 20.2.7 Sensitive Instructions

When an IA-32 processor is running in virtual-8086 mode, the CLI, STI, PUSHF, POPF, INT  $n$ , and IRET instructions are sensitive to IOPL. The IN, INS, OUT, and OUTS instructions, which are sensitive to IOPL in protected mode, are not sensitive in virtual-8086 mode.

The CPL is always 3 while running in virtual-8086 mode; if the IOPL is less than 3, an attempt to use the IOPL-sensitive instructions listed above triggers a general-protection exception (#GP). These instructions are sensitive to IOPL to give the virtual-8086 monitor a chance to emulate the facilities they affect.

## 20.2.8 Virtual-8086 Mode I/O

Many 8086 programs written for non-multitasking systems directly access I/O ports. This practice may cause problems in a multitasking environment. If more than one program accesses the same port, they may interfere with each other. Most multitasking systems require application programs to access I/O ports through the operating system. This results in simplified, centralized control.

The processor provides I/O protection for creating I/O that is compatible with the environment and transparent to 8086 programs. Designers may take any of several possible approaches to protecting I/O ports:

- Protect the I/O address space and generate exceptions for all attempts to perform I/O directly.
- Let the 8086 program perform I/O directly.
- Generate exceptions on attempts to access specific I/O ports.
- Generate exceptions on attempts to access specific memory-mapped I/O ports.

The method of controlling access to I/O ports depends upon whether they are I/O-port mapped or memory mapped.

### 20.2.8.1 I/O-Port-Mapped I/O

The I/O permission bit map in the TSS can be used to generate exceptions on attempts to access specific I/O port addresses. The I/O permission bit map of each virtual-8086-mode task determines which I/O addresses generate exceptions for that task. Because each task may have a different I/O permission bit map, the addresses that generate exceptions for one task may be different from the addresses

for another task. This differs from protected mode in which, if the CPL is less than or equal to the IOPL, I/O access is allowed without checking the I/O permission bit map. See Chapter 13, “Input/Output”, in the *Intel® 64 and IA-32 Architectures Software Developer’s Manual, Volume 1*, for more information about the I/O permission bit map.

### 20.2.8.2 Memory-Mapped I/O

In systems which use memory-mapped I/O, the paging facilities of the processor can be used to generate exceptions for attempts to access I/O ports. The virtual-8086 monitor may use paging to control memory-mapped I/O in these ways:

- Map part of the linear address space of each task that needs to perform I/O to the physical address space where I/O ports are placed. By putting the I/O ports at different addresses (in different pages), the paging mechanism can enforce isolation between tasks.
- Map part of the linear address space to pages that are not-present. This generates an exception whenever a task attempts to perform I/O to those pages. System software then can interpret the I/O operation being attempted.

Software emulation of the I/O space may require too much operating system intervention under some conditions. In these cases, it may be possible to generate an exception for only the first attempt to access I/O. The system software then may determine whether a program can be given exclusive control of I/O temporarily, the protection of the I/O space may be lifted, and the program allowed to run at full speed.

### 20.2.8.3 Special I/O Buffers

Buffers of intelligent controllers (for example, a bit-mapped frame buffer) also can be emulated using page mapping. The linear space for the buffer can be mapped to a different physical space for each virtual-8086-mode task. The virtual-8086 monitor then can control which virtual buffer to copy onto the real buffer in the physical address space.

## 20.3 INTERRUPT AND EXCEPTION HANDLING IN VIRTUAL-8086 MODE

When the processor receives an interrupt or detects an exception condition while in virtual-8086 mode, it invokes an interrupt or exception handler, just as it does in protected or real-address mode. The interrupt or exception handler that is invoked and the mechanism used to invoke it depends on the class of interrupt or exception that has been detected or generated and the state of various system flags and fields.

In virtual-8086 mode, the interrupts and exceptions are divided into three classes for the purposes of handling:

- **Class 1** — All processor-generated exceptions and all hardware interrupts, including the NMI interrupt and the hardware interrupts sent to the processor's external interrupt delivery pins. All class 1 exceptions and interrupts are handled by the protected-mode exception and interrupt handlers.
- **Class 2** — Special case for maskable hardware interrupts (Section 6.3.2, "Maskable Hardware Interrupts") when the virtual mode extensions are enabled.
- **Class 3** — All software-generated interrupts, that is interrupts generated with the INT *n* instruction<sup>1</sup>.

The method the processor uses to handle class 2 and 3 interrupts depends on the setting of the following flags and fields:

- **IOPL field (bits 12 and 13 in the EFLAGS register)** — Controls how class 3 software interrupts are handled when the processor is in virtual-8086 mode (see Section 2.3, "System Flags and Fields in the EFLAGS Register"). This field also controls the enabling of the VIF and VIP flags in the EFLAGS register when the VME flag is set. The VIF and VIP flags are provided to assist in the handling of class 2 maskable hardware interrupts.
- **VME flag (bit 0 in control register CR4)** — Enables the virtual mode extension for the processor when set (see Section 2.5, "Control Registers").
- **Software interrupt redirection bit map (32 bytes in the TSS, see Figure 20-5)** — Contains 256 flags that indicates how class 3 software interrupts should be handled when they occur in virtual-8086 mode. A software interrupt can be directed either to the interrupt and exception handlers in the currently running 8086 program or to the protected-mode interrupt and exception handlers.
- **The virtual interrupt flag (VIF) and virtual interrupt pending flag (VIP) in the EFLAGS register** — Provides **virtual interrupt support** for the handling of class 2 maskable hardware interrupts (see Section 20.3.2, "Class 2—Maskable Hardware Interrupt Handling in Virtual-8086 Mode Using the Virtual Interrupt Mechanism").

## NOTE

The VME flag, software interrupt redirection bit map, and VIF and VIP flags are only available in IA-32 processors that support the virtual mode extensions. These extensions were introduced in the IA-32 architecture with the Pentium processor.

The following sections describe the actions that processor takes and the possible actions of interrupt and exception handlers for the two classes of interrupts described

---

1. The INT 3 instruction is a special case (see the description of the INT *n* instruction in Chapter 3, "Instruction Set Reference, A-L", of the *Intel® 64 and IA-32 Architectures Software Developer's Manual, Volume 2A*).



in the previous paragraphs. These sections describe three possible types of interrupt and exception handlers:

- **Protected-mode interrupt and exceptions handlers** — These are the standard handlers that the processor calls through the protected-mode IDT.
- **Virtual-8086 monitor interrupt and exception handlers** — These handlers are resident in the virtual-8086 monitor, and they are commonly accessed through a general-protection exception (#GP, interrupt 13) that is directed to the protected-mode general-protection exception handler.
- **8086 program interrupt and exception handlers** — These handlers are part of the 8086 program that is running in virtual-8086 mode.

The following sections describe how these handlers are used, depending on the selected class and method of interrupt and exception handling.

### 20.3.1 Class 1—Hardware Interrupt and Exception Handling in Virtual-8086 Mode

In virtual-8086 mode, the Pentium, P6 family, Pentium 4, and Intel Xeon processors handle hardware interrupts and exceptions in the same manner as they are handled by the Intel486 and Intel386 processors. They invoke the protected-mode interrupt or exception handler that the interrupt or exception vector points to in the IDT. Here, the IDT entry must contain either a 32-bit trap or interrupt gate or a task gate. The following sections describe various ways that a virtual-8086 mode interrupt or exception can be handled after the protected-mode handler has been invoked.

See Section 20.3.2, “Class 2—Maskable Hardware Interrupt Handling in Virtual-8086 Mode Using the Virtual Interrupt Mechanism”, for a description of the virtual interrupt mechanism that is available for handling maskable hardware interrupts while in virtual-8086 mode. When this mechanism is either not available or not enabled, maskable hardware interrupts are handled in the same manner as exceptions, as described in the following sections.

#### 20.3.1.1 Handling an Interrupt or Exception Through a Protected-Mode Trap or Interrupt Gate

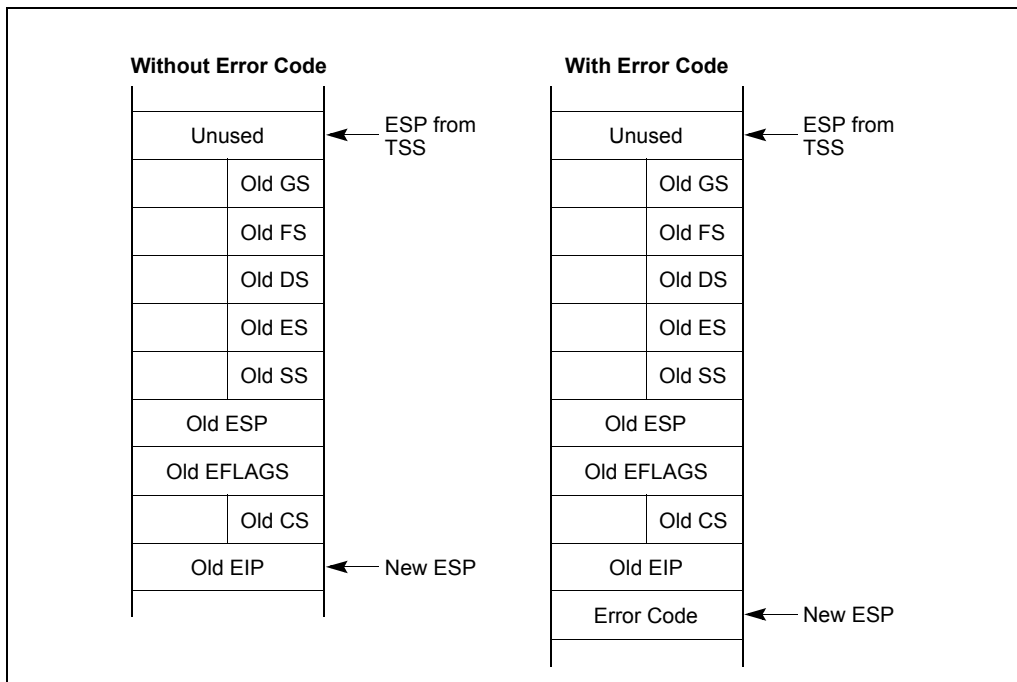
When an interrupt or exception vector points to a 32-bit trap or interrupt gate in the IDT, the gate must in turn point to a nonconforming, privilege-level 0, code segment. When accessing this code segment, processor performs the following steps.

1. Switches to 32-bit protected mode and privilege level 0.
2. Saves the state of the processor on the privilege-level 0 stack. The states of the EIP, CS, EFLAGS, ESP, SS, ES, DS, FS, and GS registers are saved (see Figure 20-4).
3. Clears the segment registers. Saving the DS, ES, FS, and GS registers on the stack and then clearing the registers lets the interrupt or exception handler safely

save and restore these registers regardless of the type segment selectors they contain (protected-mode or 8086-style). The interrupt and exception handlers, which may be called in the context of either a protected-mode task or a virtual-8086-mode task, can use the same code sequences for saving and restoring the registers for any task. Clearing these registers before execution of the IRET instruction does not cause a trap in the interrupt handler. Interrupt procedures that expect values in the segment registers or that return values in the segment registers must use the register images saved on the stack for privilege level 0.

4. Clears VM, NT, RF and TF flags (in the EFLAGS register). If the gate is an interrupt gate, clears the IF flag.
5. Begins executing the selected interrupt or exception handler.

If the trap or interrupt gate references a procedure in a conforming segment or in a segment at a privilege level other than 0, the processor generates a general-protection exception (#GP). Here, the error code is the segment selector of the code segment to which a call was attempted.



**Figure 20-4. Privilege Level 0 Stack After Interrupt or Exception in Virtual-8086 Mode**

Interrupt and exception handlers can examine the VM flag on the stack to determine if the interrupted procedure was running in virtual-8086 mode. If so, the interrupt or exception can be handled in one of three ways:

- The protected-mode interrupt or exception handler that was called can handle the interrupt or exception.
- The protected-mode interrupt or exception handler can call the virtual-8086 monitor to handle the interrupt or exception.
- The virtual-8086 monitor (if called) can in turn pass control back to the 8086 program's interrupt and exception handler.

If the interrupt or exception is handled with a protected-mode handler, the handler can return to the interrupted program in virtual-8086 mode by executing an IRET instruction. This instruction loads the EFLAGS and segment registers from the images saved in the privilege level 0 stack (see Figure 20-4). A set VM flag in the EFLAGS image causes the processor to switch back to virtual-8086 mode. The CPL at the time the IRET instruction is executed must be 0, otherwise the processor does not change the state of the VM flag.

The virtual-8086 monitor runs at privilege level 0, like the protected-mode interrupt and exception handlers. It is commonly closely tied to the protected-mode general-protection exception (#GP, vector 13) handler. If the protected-mode interrupt or exception handler calls the virtual-8086 monitor to handle the interrupt or exception, the return from the virtual-8086 monitor to the interrupted virtual-8086 mode program requires two return instructions: a RET instruction to return to the protected-mode handler and an IRET instruction to return to the interrupted program.

The virtual-8086 monitor has the option of directing the interrupt and exception back to an interrupt or exception handler that is part of the interrupted 8086 program, as described in Section 20.3.1.2, "Handling an Interrupt or Exception With an 8086 Program Interrupt or Exception Handler".

### 20.3.1.2 Handling an Interrupt or Exception With an 8086 Program Interrupt or Exception Handler

Because it was designed to run on an 8086 processor, an 8086 program running in a virtual-8086-mode task contains an 8086-style interrupt vector table, which starts at linear address 0. If the virtual-8086 monitor correctly directs an interrupt or exception vector back to the virtual-8086-mode task it came from, the handlers in the 8086 program can handle the interrupt or exception. The virtual-8086 monitor must carry out the following steps to send an interrupt or exception back to the 8086 program:

1. Use the 8086 interrupt vector to locate the appropriate handler procedure in the 8086 program interrupt table.

2. Store the EFLAGS (low-order 16 bits only), CS and EIP values of the 8086 program on the privilege-level 3 stack. This is the stack that the virtual-8086-mode task is using. (The 8086 handler may use or modify this information.)
3. Change the return link on the privilege-level 0 stack to point to the privilege-level 3 handler procedure.
4. Execute an IRET instruction to pass control to the 8086 program handler.
5. When the IRET instruction from the privilege-level 3 handler triggers a general-protection exception (#GP) and thus effectively again calls the virtual-8086 monitor, restore the return link on the privilege-level 0 stack to point to the original, interrupted, privilege-level 3 procedure.
6. Copy the low order 16 bits of the EFLAGS image from the privilege-level 3 stack to the privilege-level 0 stack (because some 8086 handlers modify these flags to return information to the code that caused the interrupt).
7. Execute an IRET instruction to pass control back to the interrupted 8086 program.

Note that if an operating system intends to support all 8086 MS-DOS-based programs, it is necessary to use the actual 8086 interrupt and exception handlers supplied with the program. The reason for this is that some programs modify their own interrupt vector table to substitute (or hook in series) their own specialized interrupt and exception handlers.

### 20.3.1.3 Handling an Interrupt or Exception Through a Task Gate

When an interrupt or exception vector points to a task gate in the IDT, the processor performs a task switch to the selected interrupt- or exception-handling task. The following actions are carried out as part of this task switch:

1. The EFLAGS register with the VM flag set is saved in the current TSS.
2. The link field in the TSS of the called task is loaded with the segment selector of the TSS for the interrupted virtual-8086-mode task.
3. The EFLAGS register is loaded from the image in the new TSS, which clears the VM flag and causes the processor to switch to protected mode.
4. The NT flag in the EFLAGS register is set.
5. The processor begins executing the selected interrupt- or exception-handler task.

When an IRET instruction is executed in the handler task and the NT flag in the EFLAGS register is set, the processor switches from a protected-mode interrupt- or exception-handler task back to a virtual-8086-mode task. Here, the EFLAGS and segment registers are loaded from images saved in the TSS for the virtual-8086-mode task. If the VM flag is set in the EFLAGS image, the processor switches back to virtual-8086 mode on the task switch. The CPL at the time the IRET instruction is

executed must be 0, otherwise the processor does not change the state of the VM flag.

### 20.3.2 Class 2—Maskable Hardware Interrupt Handling in Virtual-8086 Mode Using the Virtual Interrupt Mechanism

Maskable hardware interrupts are those interrupts that are delivered through the INTR# pin or through an interrupt request to the local APIC (see Section 6.3.2, “Maskable Hardware Interrupts”). These interrupts can be inhibited (masked) from interrupting an executing program or task by clearing the IF flag in the EFLAGS register.

When the VME flag in control register CR4 is set and the IOPL field in the EFLAGS register is less than 3, two additional flags are activated in the EFLAGS register:

- VIF (virtual interrupt) flag, bit 19 of the EFLAGS register.
- VIP (virtual interrupt pending) flag, bit 20 of the EFLAGS register.

These flags provide the virtual-8086 monitor with more efficient control over handling maskable hardware interrupts that occur during virtual-8086 mode tasks. They also reduce interrupt-handling overhead, by eliminating the need for all IF related operations (such as PUSHF, POPF, CLI, and STI instructions) to trap to the virtual-8086 monitor. The purpose and use of these flags are as follows.

#### NOTE

The VIF and VIP flags are only available in IA-32 processors that support the virtual mode extensions. These extensions were introduced in the IA-32 architecture with the Pentium processor. When this mechanism is either not available or not enabled, maskable hardware interrupts are handled as class 1 interrupts. Here, if VIF and VIP flags are needed, the virtual-8086 monitor can implement them in software.

Existing 8086 programs commonly set and clear the IF flag in the EFLAGS register to enable and disable maskable hardware interrupts, respectively; for example, to disable interrupts while handling another interrupt or an exception. This practice works well in single task environments, but can cause problems in multitasking and multiple-processor environments, where it is often desirable to prevent an application program from having direct control over the handling of hardware interrupts. When using earlier IA-32 processors, this problem was often solved by creating a virtual IF flag in software. The IA-32 processors (beginning with the Pentium processor) provide hardware support for this virtual IF flag through the VIF and VIP flags.

The VIF flag is a virtualized version of the IF flag, which an application program running from within a virtual-8086 task can use to control the handling of maskable hardware interrupts. When the VIF flag is enabled, the CLI and STI instructions operate on the VIF flag instead of the IF flag. When an 8086 program executes the

CLI instruction, the processor clears the VIF flag to request that the virtual-8086 monitor inhibit maskable hardware interrupts from interrupting program execution; when it executes the STI instruction, the processor sets the VIF flag requesting that the virtual-8086 monitor enable maskable hardware interrupts for the 8086 program. But actually the IF flag, managed by the operating system, always controls whether maskable hardware interrupts are enabled. Also, if under these circumstances an 8086 program tries to read or change the IF flag using the PUSHF or POPF instructions, the processor will change the VIF flag instead, leaving IF unchanged.

The VIP flag provides software a means of recording the existence of a deferred (or pending) maskable hardware interrupt. This flag is read by the processor but never explicitly written by the processor; it can only be written by software.

If the IF flag is set and the VIF and VIP flags are enabled, and the processor receives a maskable hardware interrupt (interrupt vector 0 through 255), the processor performs and the interrupt handler software should perform the following operations:

1. The processor invokes the protected-mode interrupt handler for the interrupt received, as described in the following steps. These steps are almost identical to those described for method 1 interrupt and exception handling in Section 20.3.1.1, "Handling an Interrupt or Exception Through a Protected-Mode Trap or Interrupt Gate":
  - a. Switches to 32-bit protected mode and privilege level 0.
  - b. Saves the state of the processor on the privilege-level 0 stack. The states of the EIP, CS, EFLAGS, ESP, SS, ES, DS, FS, and GS registers are saved (see Figure 20-4).
  - c. Clears the segment registers.
  - d. Clears the VM flag in the EFLAGS register.
  - e. Begins executing the selected protected-mode interrupt handler.
2. The recommended action of the protected-mode interrupt handler is to read the VM flag from the EFLAGS image on the stack. If this flag is set, the handler makes a call to the virtual-8086 monitor.
3. The virtual-8086 monitor should read the VIF flag in the EFLAGS register.
  - If the VIF flag is clear, the virtual-8086 monitor sets the VIP flag in the EFLAGS image on the stack to indicate that there is a deferred interrupt pending and returns to the protected-mode handler.
  - If the VIF flag is set, the virtual-8086 monitor can handle the interrupt if it "belongs" to the 8086 program running in the interrupted virtual-8086 task; otherwise, it can call the protected-mode interrupt handler to handle the interrupt.
4. The protected-mode handler executes a return to the program executing in virtual-8086 mode.

5. Upon returning to virtual-8086 mode, the processor continues execution of the 8086 program.

When the 8086 program is ready to receive maskable hardware interrupts, it executes the STI instruction to set the VIF flag (enabling maskable hardware interrupts). Prior to setting the VIF flag, the processor automatically checks the VIP flag and does one of the following, depending on the state of the flag:

- If the VIP flag is clear (indicating no pending interrupts), the processor sets the VIF flag.
- If the VIP flag is set (indicating a pending interrupt), the processor generates a general-protection exception (#GP).

The recommended action of the protected-mode general-protection exception handler is to then call the virtual-8086 monitor and let it handle the pending interrupt. After handling the pending interrupt, the typical action of the virtual-8086 monitor is to clear the VIP flag and set the VIF flag in the EFLAGS image on the stack, and then execute a return to the virtual-8086 mode. The next time the processor receives a maskable hardware interrupt, it will then handle it as described in steps 1 through 5 earlier in this section.

If the processor finds that both the VIF and VIP flags are set at the beginning of an instruction, it generates a general-protection exception. This action allows the virtual-8086 monitor to handle the pending interrupt for the virtual-8086 mode task for which the VIF flag is enabled. Note that this situation can only occur immediately following execution of a POPF or IRET instruction or upon entering a virtual-8086 mode task through a task switch.

Note that the states of the VIF and VIP flags are not modified in real-address mode or during transitions between real-address and protected modes.

### NOTE

The virtual interrupt mechanism described in this section is also available for use in protected mode, see Section 20.4, "Protected-Mode Virtual Interrupts".

### 20.3.3 Class 3—Software Interrupt Handling in Virtual-8086 Mode

When the processor receives a software interrupt (an interrupt generated with the INT *n* instruction) while in virtual-8086 mode, it can use any of six different methods to handle the interrupt. The method selected depends on the settings of the VME flag in control register CR4, the IOPL field in the EFLAGS register, and the software interrupt redirection bit map in the TSS. Table 20-2 lists the six methods of handling software interrupts in virtual-8086 mode and the respective settings of the VME flag, IOPL field, and the bits in the interrupt redirection bit map for each method. The table also summarizes the various actions the processor takes for each method.

The VME flag enables the virtual mode extensions for the Pentium and later IA-32 processors. When this flag is clear, the processor responds to interrupts and excep-

tions in virtual-8086 mode in the same manner as an Intel386 or Intel486 processor does. When this flag is set, the virtual mode extension provides the following enhancements to virtual-8086 mode:

- Speeds up the handling of software-generated interrupts in virtual-8086 mode by allowing the processor to bypass the virtual-8086 monitor and redirect software interrupts back to the interrupt handlers that are part of the currently running 8086 program.
- Supports virtual interrupts for software written to run on the 8086 processor.

The IOPL value interacts with the VME flag and the bits in the interrupt redirection bit map to determine how specific software interrupts should be handled.

The software interrupt redirection bit map (see Figure 20-5) is a 32-byte field in the TSS. This map is located directly below the I/O permission bit map in the TSS. Each bit in the interrupt redirection bit map is mapped to an interrupt vector. Bit 0 in the interrupt redirection bit map (which maps to vector zero in the interrupt table) is located at the I/O base map address in the TSS minus 32 bytes. When a bit in this bit map is set, it indicates that the associated software interrupt (interrupt generated with an INT *n* instruction) should be handled through the protected-mode IDT and interrupt and exception handlers. When a bit in this bit map is clear, the processor redirects the associated software interrupt back to the interrupt table in the 8086 program (located at linear address 0 in the program's address space).

### NOTE

The software interrupt redirection bit map does not affect hardware generated interrupts and exceptions. Hardware generated interrupts and exceptions are always handled by the protected-mode interrupt and exception handlers.

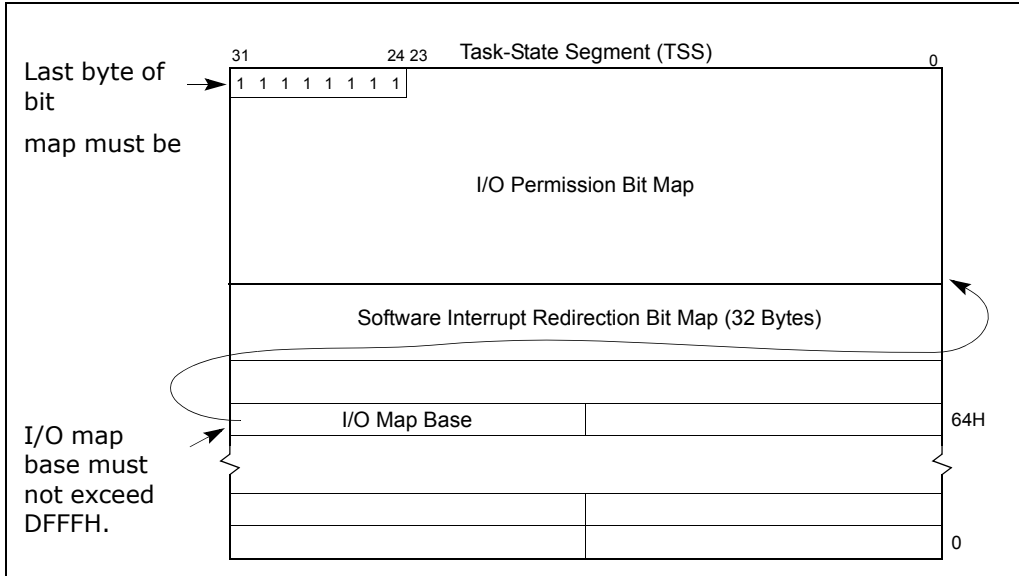


**Table 20-2. Software Interrupt Handling Methods While in Virtual-8086 Mode**

Method	VME	IOPL	Bit in Redir. Bitmap*	Processor Action
1	0	3	X	Interrupt directed to a protected-mode interrupt handler: <ul style="list-style-type: none"> <li>Switches to privilege-level 0 stack</li> <li>Pushes GS, FS, DS and ES onto privilege-level 0 stack</li> <li>Pushes SS, ESP, EFLAGS, CS and EIP of interrupted task onto privilege-level 0 stack</li> <li>Clears VM, RF, NT, and TF flags</li> <li>If serviced through interrupt gate, clears IF flag</li> <li>Clears GS, FS, DS and ES to 0</li> <li>Sets CS and EIP from interrupt gate</li> </ul>
2	0	< 3	X	Interrupt directed to protected-mode general-protection exception (#GP) handler.
3	1	< 3	1	Interrupt directed to a protected-mode general-protection exception (#GP) handler; VIF and VIP flag support for handling class 2 maskable hardware interrupts.
4	1	3	1	Interrupt directed to protected-mode interrupt handler: (see method 1 processor action).
5	1	3	0	Interrupt redirected to 8086 program interrupt handler: <ul style="list-style-type: none"> <li>Pushes EFLAGS</li> <li>Pushes CS and EIP (lower 16 bits only)</li> <li>Clears IF flag</li> <li>Clears TF flag</li> <li>Loads CS and EIP (lower 16 bits only) from selected entry in the interrupt vector table of the current virtual-8086 task</li> </ul>
6	1	< 3	0	Interrupt redirected to 8086 program interrupt handler; VIF and VIP flag support for handling class 2 maskable hardware interrupts: <ul style="list-style-type: none"> <li>Pushes EFLAGS with IOPL set to 3 and VIF copied to IF</li> <li>Pushes CS and EIP (lower 16 bits only)</li> <li>Clears the VIF flag</li> <li>Clears TF flag</li> <li>Loads CS and EIP (lower 16 bits only) from selected entry in the interrupt vector table of the current virtual-8086 task</li> </ul>

**NOTE:**

\* When set to 0, software interrupt is redirected back to the 8086 program interrupt handler; when set to 1, interrupt is directed to protected-mode handler.



**Figure 20-5. Software Interrupt Redirection Bit Map in TSS**

Redirecting software interrupts back to the 8086 program potentially speeds up interrupt handling because a switch back and forth between virtual-8086 mode and protected mode is not required. This latter interrupt-handling technique is particularly useful for 8086 operating systems (such as MS-DOS) that use the `INT n` instruction to call operating system procedures.

The `CPUID` instruction can be used to verify that the virtual mode extension is implemented on the processor. Bit 1 of the feature flags register (EDX) indicates the availability of the virtual mode extension (see “`CPUID—CPU Identification`” in Chapter 3, “`Instruction Set Reference, A-L`”, of the *Intel® 64 and IA-32 Architectures Software Developer’s Manual, Volume 2A*).

The following sections describe the six methods (or mechanisms) for handling software interrupts in virtual-8086 mode. See Section 20.3.2, “`Class 2—Maskable Hardware Interrupt Handling in Virtual-8086 Mode Using the Virtual Interrupt Mechanism`”, for a description of the use of the VIF and VIP flags in the EFLAGS register for handling maskable hardware interrupts.

### 20.3.3.1 Method 1: Software Interrupt Handling

When the VME flag in control register CR4 is clear and the IOPL field is 3, a Pentium or later IA-32 processor handles software interrupts in the same manner as they are handled by an Intel386 or Intel486 processor. It executes an implicit call to the inter-

rupt handler in the protected-mode IDT pointed to by the interrupt vector. See Section 20.3.1, “Class 1—Hardware Interrupt and Exception Handling in Virtual-8086 Mode”, for a complete description of this mechanism and its possible uses.

### 20.3.3.2 Methods 2 and 3: Software Interrupt Handling

When a software interrupt occurs in virtual-8086 mode and the method 2 or 3 conditions are present, the processor generates a general-protection exception (#GP). Method 2 is enabled when the VME flag is set to 0 and the IOPL value is less than 3. Here the IOPL value is used to bypass the protected-mode interrupt handlers and cause any software interrupt that occurs in virtual-8086 mode to be treated as a protected-mode general-protection exception (#GP). The general-protection exception handler calls the virtual-8086 monitor, which can then emulate an 8086-program interrupt handler or pass control back to the 8086 program’s handler, as described in Section 20.3.1.2, “Handling an Interrupt or Exception With an 8086 Program Interrupt or Exception Handler”.

Method 3 is enabled when the VME flag is set to 1, the IOPL value is less than 3, and the corresponding bit for the software interrupt in the software interrupt redirection bit map is set to 1. Here, the processor performs the same operation as it does for method 2 software interrupt handling. If the corresponding bit for the software interrupt in the software interrupt redirection bit map is set to 0, the interrupt is handled using method 6 (see Section 20.3.3.5, “Method 6: Software Interrupt Handling”).

### 20.3.3.3 Method 4: Software Interrupt Handling

Method 4 handling is enabled when the VME flag is set to 1, the IOPL value is 3, and the bit for the interrupt vector in the redirection bit map is set to 1. Method 4 software interrupt handling allows method 1 style handling when the virtual mode extension is enabled; that is, the interrupt is directed to a protected-mode handler (see Section 20.3.3.1, “Method 1: Software Interrupt Handling”).

### 20.3.3.4 Method 5: Software Interrupt Handling

Method 5 software interrupt handling provides a streamlined method of redirecting software interrupts (invoked with the INT *n* instruction) that occur in virtual 8086 mode back to the 8086 program’s interrupt vector table and its interrupt handlers. Method 5 handling is enabled when the VME flag is set to 1, the IOPL value is 3, and the bit for the interrupt vector in the redirection bit map is set to 0. The processor performs the following actions to make an implicit call to the selected 8086 program interrupt handler:

1. Pushes the low-order 16 bits of the EFLAGS register onto the stack.
2. Pushes the current values of the CS and EIP registers onto the current stack. (Only the 16 least-significant bits of the EIP register are pushed and no stack switch occurs.)

3. Clears the IF flag in the EFLAGS register to disable interrupts.
4. Clears the TF flag, in the EFLAGS register.
5. Locates the 8086 program interrupt vector table at linear address 0 for the 8086-mode task.
6. Loads the CS and EIP registers with values from the interrupt vector table entry pointed to by the interrupt vector number. Only the 16 low-order bits of the EIP are loaded and the 16 high-order bits are set to 0. The interrupt vector table is assumed to be at linear address 0 of the current virtual-8086 task.
7. Begins executing the selected interrupt handler.

An IRET instruction at the end of the handler procedure reverses these steps to return program control to the interrupted 8086 program.

Note that with method 5 handling, a mode switch from virtual-8086 mode to protected mode does not occur. The processor remains in virtual-8086 mode throughout the interrupt-handling operation.

The method 5 handling actions are virtually identical to the actions the processor takes when handling software interrupts in real-address mode. The benefit of using method 5 handling to access the 8086 program handlers is that it avoids the overhead of methods 2 and 3 handling, which requires first going to the virtual-8086 monitor, then to the 8086 program handler, then back again to the virtual-8086 monitor, before returning to the interrupted 8086 program (see Section 20.3.1.2, "Handling an Interrupt or Exception With an 8086 Program Interrupt or Exception Handler").

### NOTE

Methods 1 and 4 handling can handle a software interrupt in a virtual-8086 task with a regular protected-mode handler, but this approach requires all virtual-8086 tasks to use the same software interrupt handlers, which generally does not give sufficient latitude to the programs running in the virtual-8086 tasks, particularly MS-DOS programs.

#### 20.3.3.5 Method 6: Software Interrupt Handling

Method 6 handling is enabled when the VME flag is set to 1, the IOPL value is less than 3, and the bit for the interrupt or exception vector in the redirection bit map is set to 0. With method 6 interrupt handling, software interrupts are handled in the same manner as was described for method 5 handling (see Section 20.3.3.4, "Method 5: Software Interrupt Handling").

Method 6 differs from method 5 in that with the IOPL value set to less than 3, the VIF and VIP flags in the EFLAGS register are enabled, providing virtual interrupt support for handling class 2 maskable hardware interrupts (see Section 20.3.2, "Class 2—Maskable Hardware Interrupt Handling in Virtual-8086 Mode Using the Virtual Interrupt Mechanism"). These flags provide the virtual-8086 monitor with an effi-

cient means of handling maskable hardware interrupts that occur during a virtual-8086 mode task. Also, because the IOPL value is less than 3 and the VIF flag is enabled, the information pushed on the stack by the processor when invoking the interrupt handler is slightly different between methods 5 and 6 (see Table 20-2).

## 20.4 PROTECTED-MODE VIRTUAL INTERRUPTS

The IA-32 processors (beginning with the Pentium processor) also support the VIF and VIP flags in the EFLAGS register in protected mode by setting the PVI (protected-mode virtual interrupt) flag in the CR4 register. Setting the PVI flag allows applications running at privilege level 3 to execute the CLI and STI instructions without causing a general-protection exception (#GP) or affecting hardware interrupts.

When the PVI flag is set to 1, the CPL is 3, and the IOPL is less than 3, the STI and CLI instructions set and clear the VIF flag in the EFLAGS register, leaving IF unaffected. In this mode of operation, an application running in protected mode and at a CPL of 3 can inhibit interrupts in the same manner as is described in Section 20.3.2, “Class 2—Maskable Hardware Interrupt Handling in Virtual-8086 Mode Using the Virtual Interrupt Mechanism”, for a virtual-8086 mode task. When the application executes the CLI instruction, the processor clears the VIF flag. If the processor receives a maskable hardware interrupt, the processor invokes the protected-mode interrupt handler. This handler checks the state of the VIF flag in the EFLAGS register. If the VIF flag is clear (indicating that the active task does not want to have interrupts handled now), the handler sets the VIP flag in the EFLAGS image on the stack and returns to the privilege-level 3 application, which continues program execution. When the application executes a STI instruction to set the VIF flag, the processor automatically invokes the general-protection exception handler, which can then handle the pending interrupt. After handing the pending interrupt, the handler typically sets the VIF flag and clears the VIP flag in the EFLAGS image on the stack and executes a return to the application program. The next time the processor receives a maskable hardware interrupt, the processor will handle it in the normal manner for interrupts received while the processor is operating at a CPL of 3.

As with the virtual mode extension (enabled with the VME flag in the CR4 register), the protected-mode virtual interrupt extension only affects maskable hardware interrupts (interrupt vectors 32 through 255). NMI interrupts and exceptions are handled in the normal manner.

When protected-mode virtual interrupts are disabled (that is, when the PVI flag in control register CR4 is set to 0, the CPL is less than 3, or the IOPL value is 3), then the CLI and STI instructions execute in a manner compatible with the Intel486 processor. That is, if the CPL is greater (less privileged) than the I/O privilege level (IOPL), a general-protection exception occurs. If the IOPL value is 3, CLI and STI clear or set the IF flag, respectively.

PUSHF, POPF, IRET and INT are executed like in the Intel486 processor, regardless of whether protected-mode virtual interrupts are enabled.

It is only possible to enter virtual-8086 mode through a task switch or the execution of an IRET instruction, and it is only possible to leave virtual-8086 mode by faulting to a protected-mode interrupt handler (typically the general-protection exception handler, which in turn calls the virtual 8086-mode monitor). In both cases, the EFLAGS register is saved and restored. This is not true, however, in protected mode when the PVI flag is set and the processor is not in virtual-8086 mode. Here, it is possible to call a procedure at a different privilege level, in which case the EFLAGS register is not saved or modified. However, the states of VIF and VIP flags are never examined by the processor when the CPL is not 3.

# CHAPTER 21

## MIXING 16-BIT AND 32-BIT CODE

---

Program modules written to run on IA-32 processors can be either 16-bit modules or 32-bit modules. Table 21-1 shows the characteristic of 16-bit and 32-bit modules.

**Table 21-1. Characteristics of 16-Bit and 32-Bit Program Modules**

Characteristic	16-Bit Program Modules	32-Bit Program Modules
Segment Size	0 to 64 KBytes	0 to 4 GBytes
Operand Sizes	8 bits and 16 bits	8 bits and 32 bits
Pointer Offset Size (Address Size)	16 bits	32 bits
Stack Pointer Size	16 Bits	32 Bits
Control Transfers Allowed to Code Segments of This Size	16 Bits	32 Bits

The IA-32 processors function most efficiently when executing 32-bit program modules. They can, however, also execute 16-bit program modules, in any of the following ways:

- In real-address mode.
- In virtual-8086 mode.
- System management mode (SMM).
- As a protected-mode task, when the code, data, and stack segments for the task are all configured as a 16-bit segments.
- By integrating 16-bit and 32-bit segments into a single protected-mode task.
- By integrating 16-bit operations into 32-bit code segments.

Real-address mode, virtual-8086 mode, and SMM are native 16-bit modes. A legacy program assembled and/or compiled to run on an Intel 8086 or Intel 286 processor should run in real-address mode or virtual-8086 mode without modification. Sixteen-bit program modules can also be written to run in real-address mode for handling system initialization or to run in SMM for handling system management functions. See Chapter 20, "8086 Emulation," for detailed information on real-address mode and virtual-8086 mode; see Chapter 33, "System Management Mode," for information on SMM.

This chapter describes how to integrate 16-bit program modules with 32-bit program modules when operating in protected mode and how to mix 16-bit and 32-bit code within 32-bit code segments.

## 21.1 DEFINING 16-BIT AND 32-BIT PROGRAM MODULES

The following IA-32 architecture mechanisms are used to distinguish between and support 16-bit and 32-bit segments and operations:

- The D (default operand and address size) flag in code-segment descriptors.
- The B (default stack size) flag in stack-segment descriptors.
- 16-bit and 32-bit call gates, interrupt gates, and trap gates.
- Operand-size and address-size instruction prefixes.
- 16-bit and 32-bit general-purpose registers.

The D flag in a code-segment descriptor determines the default operand-size and address-size for the instructions of a code segment. (In real-address mode and virtual-8086 mode, which do not use segment descriptors, the default is 16 bits.) A code segment with its D flag set is a 32-bit segment; a code segment with its D flag clear is a 16-bit segment.

The B flag in the stack-segment descriptor specifies the size of stack pointer (the 32-bit ESP register or the 16-bit SP register) used by the processor for implicit stack references. The B flag for all data descriptors also controls upper address range for expand down segments.

When transferring program control to another code segment through a call gate, interrupt gate, or trap gate, the operand size used during the transfer is determined by the type of gate used (16-bit or 32-bit), (not by the D-flag or prefix of the transfer instruction). The gate type determines how return information is saved on the stack (or stacks).

For most efficient and trouble-free operation of the processor, 32-bit programs or tasks should have the D flag in the code-segment descriptor and the B flag in the stack-segment descriptor set, and 16-bit programs or tasks should have these flags clear. Program control transfers from 16-bit segments to 32-bit segments (and vice versa) are handled most efficiently through call, interrupt, or trap gates.

Instruction prefixes can be used to override the default operand size and address size of a code segment. These prefixes can be used in real-address mode as well as in protected mode and virtual-8086 mode. An operand-size or address-size prefix only changes the size for the duration of the instruction.

## 21.2 MIXING 16-BIT AND 32-BIT OPERATIONS WITHIN A CODE SEGMENT

The following two instruction prefixes allow mixing of 32-bit and 16-bit operations within one segment:

- The operand-size prefix (66H)
- The address-size prefix (67H)



These prefixes reverse the default size selected by the D flag in the code-segment descriptor. For example, the processor can interpret the (MOV *mem, reg*) instruction in any of four ways:

- In a 32-bit code segment:
  - Moves 32 bits from a 32-bit register to memory using a 32-bit effective address.
  - If preceded by an operand-size prefix, moves 16 bits from a 16-bit register to memory using a 32-bit effective address.
  - If preceded by an address-size prefix, moves 32 bits from a 32-bit register to memory using a 16-bit effective address.
  - If preceded by both an address-size prefix and an operand-size prefix, moves 16 bits from a 16-bit register to memory using a 16-bit effective address.
- In a 16-bit code segment:
  - Moves 16 bits from a 16-bit register to memory using a 16-bit effective address.
  - If preceded by an operand-size prefix, moves 32 bits from a 32-bit register to memory using a 16-bit effective address.
  - If preceded by an address-size prefix, moves 16 bits from a 16-bit register to memory using a 32-bit effective address.
  - If preceded by both an address-size prefix and an operand-size prefix, moves 32 bits from a 32-bit register to memory using a 32-bit effective address.

The previous examples show that any instruction can generate any combination of operand size and address size regardless of whether the instruction is in a 16- or 32-bit segment. The choice of the 16- or 32-bit default for a code segment is normally based on the following criteria:

- **Performance** — Always use 32-bit code segments when possible. They run much faster than 16-bit code segments on P6 family processors, and somewhat faster on earlier IA-32 processors.
- **The operating system the code segment will be running on** — If the operating system is a 16-bit operating system, it may not support 32-bit program modules.
- **Mode of operation** — If the code segment is being designed to run in real-address mode, virtual-8086 mode, or SMM, it must be a 16-bit code segment.
- **Backward compatibility to earlier IA-32 processors** — If a code segment must be able to run on an Intel 8086 or Intel 286 processor, it must be a 16-bit code segment.

## 21.3 SHARING DATA AMONG MIXED-SIZE CODE SEGMENTS

Data segments can be accessed from both 16-bit and 32-bit code segments. When a data segment that is larger than 64 KBytes is to be shared among 16- and 32-bit code segments, the data that is to be accessed from the 16-bit code segments must be located within the first 64 KBytes of the data segment. The reason for this is that 16-bit pointers by definition can only point to the first 64 KBytes of a segment.

A stack that spans less than 64 KBytes can be shared by both 16- and 32-bit code segments. This class of stacks includes:

- Stacks in expand-up segments with the G (granularity) and B (big) flags in the stack-segment descriptor clear.
- Stacks in expand-down segments with the G and B flags clear.
- Stacks in expand-up segments with the G flag set and the B flag clear and where the stack is contained completely within the lower 64 KBytes. (Offsets greater than FFFFH can be used for data, other than the stack, which is not shared.)

See Section 3.4.5, "Segment Descriptors," for a description of the G and B flags and the expand-down stack type.

The B flag cannot, in general, be used to change the size of stack used by a 16-bit code segment. This flag controls the size of the stack pointer only for implicit stack references such as those caused by interrupts, exceptions, and the PUSH, POP, CALL, and RET instructions. It does not control explicit stack references, such as accesses to parameters or local variables. A 16-bit code segment can use a 32-bit stack only if the code is modified so that all explicit references to the stack are preceded by the 32-bit address-size prefix, causing those references to use 32-bit addressing and explicit writes to the stack pointer are preceded by a 32-bit operand-size prefix.

In 32-bit, expand-down segments, all offsets may be greater than 64 KBytes; therefore, 16-bit code cannot use this kind of stack segment unless the code segment is modified to use 32-bit addressing.

## 21.4 TRANSFERRING CONTROL AMONG MIXED-SIZE CODE SEGMENTS

There are three ways for a procedure in a 16-bit code segment to safely make a call to a 32-bit code segment:

- Make the call through a 32-bit call gate.
- Make a 16-bit call to a 32-bit interface procedure. The interface procedure then makes a 32-bit call to the intended destination.
- Modify the 16-bit procedure, inserting an operand-size prefix before the call, to change it to a 32-bit call.

Likewise, there are three ways for procedure in a 32-bit code segment to safely make a call to a 16-bit code segment:

- Make the call through a 16-bit call gate. Here, the EIP value at the CALL instruction cannot exceed FFFFH.
- Make a 32-bit call to a 16-bit interface procedure. The interface procedure then makes a 16-bit call to the intended destination.
- Modify the 32-bit procedure, inserting an operand-size prefix before the call, changing it to a 16-bit call. Be certain that the return offset does not exceed FFFFH.

These methods of transferring program control overcome the following architectural limitations imposed on calls between 16-bit and 32-bit code segments:

- Pointers from 16-bit code segments (which by default can only be 16 bits) cannot be used to address data or code located beyond FFFFH in a 32-bit segment.
- The operand-size attributes for a CALL and its companion RETURN instruction must be the same to maintain stack coherency. This is also true for implicit calls to interrupt and exception handlers and their companion IRET instructions.
- A 32-bit parameters (particularly a pointer parameter) greater than FFFFH cannot be squeezed into a 16-bit parameter location on a stack.
- The size of the stack pointer (SP or ESP) changes when switching between 16-bit and 32-bit code segments.

These limitations are discussed in greater detail in the following sections.

### 21.4.1 Code-Segment Pointer Size

For control-transfer instructions that use a pointer to identify the next instruction (that is, those that do not use gates), the operand-size attribute determines the size of the offset portion of the pointer. The implications of this rule are as follows:

- A JMP, CALL, or RET instruction from a 32-bit segment to a 16-bit segment is always possible using a 32-bit operand size, providing the 32-bit pointer does not exceed FFFFH.
- A JMP, CALL, or RET instruction from a 16-bit segment to a 32-bit segment cannot address a destination greater than FFFFH, unless the instruction is given an operand-size prefix.

See Section 21.4.5, “Writing Interface Procedures,” for an interface procedure that can transfer program control from 16-bit segments to destinations in 32-bit segments beyond FFFFH.

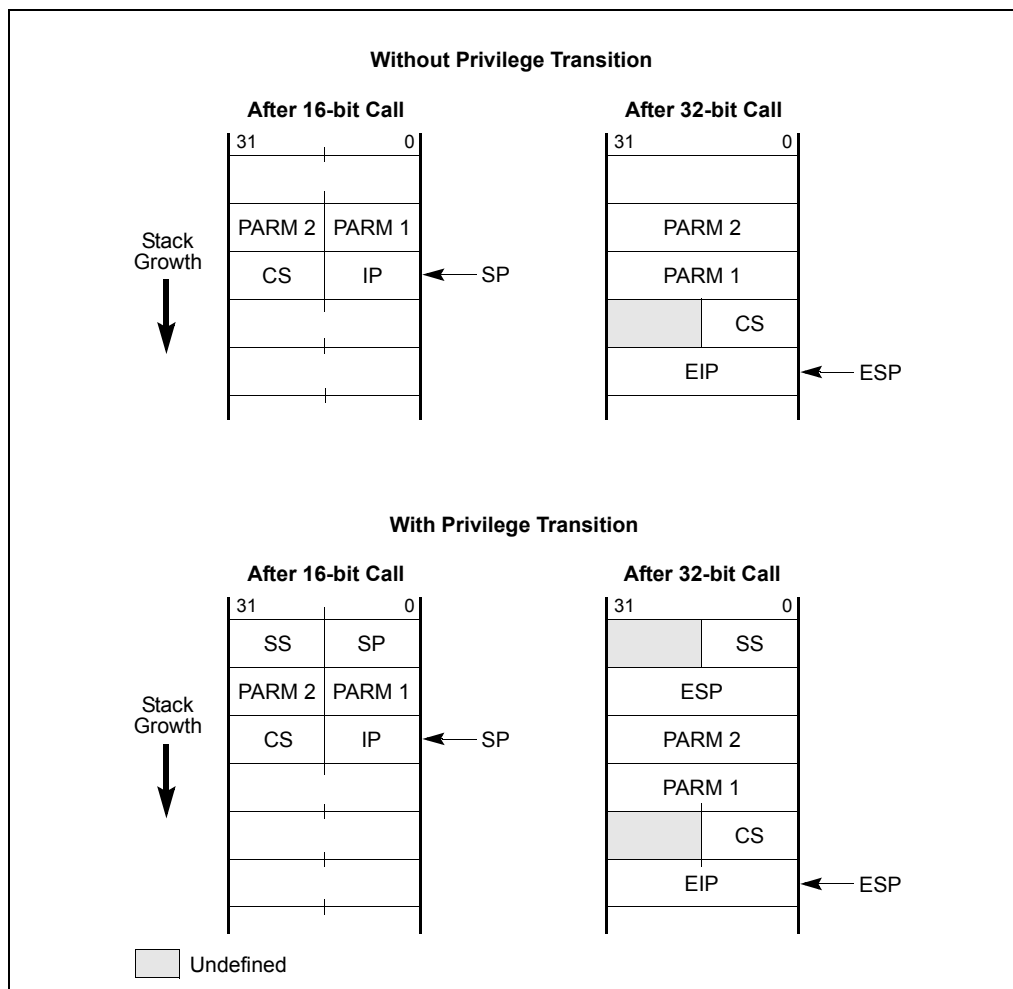
### 21.4.2 Stack Management for Control Transfer

Because the stack is managed differently for 16-bit procedure calls than for 32-bit calls, the operand-size attribute of the RET instruction must match that of the CALL

## MIXING 16-BIT AND 32-BIT CODE

instruction (see Figure 21-1). On a 16-bit call, the processor pushes the contents of the 16-bit IP register and (for calls between privilege levels) the 16-bit SP register. The matching RET instruction must also use a 16-bit operand size to pop these 16-bit values from the stack into the 16-bit registers.

A 32-bit CALL instruction pushes the contents of the 32-bit EIP register and (for inter-privilege-level calls) the 32-bit ESP register. Here, the matching RET instruction must use a 32-bit operand size to pop these 32-bit values from the stack into the 32-bit registers. If the two parts of a CALL/RET instruction pair do not have matching operand sizes, the stack will not be managed correctly and the values of the instruction pointer and stack pointer will not be restored to correct values.



**Figure 21-1. Stack after Far 16- and 32-Bit Calls**

While executing 32-bit code, if a call is made to a 16-bit code segment which is at the same or a more privileged level (that is, the DPL of the called code segment is less than or equal to the CPL of the calling code segment) through a 16-bit call gate, then the upper 16-bits of the ESP register may be unreliable upon returning to the 32-bit code segment (that is, after executing a RET in the 16-bit code segment).

When the CALL instruction and its matching RET instruction are in code segments that have D flags with the same values (that is, both are 32-bit code segments or both are 16-bit code segments), the default settings may be used. When the CALL instruction and its matching RET instruction are in segments which have different D-flag settings, an operand-size prefix must be used.

### 21.4.2.1 Controlling the Operand-Size Attribute For a Call

Three things can determine the operand-size of a call:

- The D flag in the segment descriptor for the calling code segment.
- An operand-size instruction prefix.
- The type of call gate (16-bit or 32-bit), if a call is made through a call gate.

When a call is made with a pointer (rather than a call gate), the D flag for the calling code segment determines the operand-size for the CALL instruction. This operand-size attribute can be overridden by prepending an operand-size prefix to the CALL instruction. So, for example, if the D flag for a code segment is set for 16 bits and the operand-size prefix is used with a CALL instruction, the processor will cause the information stored on the stack to be stored in 32-bit format. If the call is to a 32-bit code segment, the instructions in that code segment will be able to read the stack coherently. Also, a RET instruction from the 32-bit code segment without an operand-size prefix will maintain stack coherency with the 16-bit code segment being returned to.

When a CALL instruction references a call-gate descriptor, the type of call is determined by the type of call gate (16-bit or 32-bit). The offset to the destination in the code segment being called is taken from the gate descriptor; therefore, if a 32-bit call gate is used, a procedure in a 16-bit code segment can call a procedure located more than 64 KBytes from the base of a 32-bit code segment, because a 32-bit call gate uses a 32-bit offset.

Note that regardless of the operand size of the call and how it is determined, the size of the stack pointer used (SP or ESP) is always controlled by the B flag in the stack-segment descriptor currently in use (that is, when B is clear, SP is used, and when B is set, ESP is used).

An unmodified 16-bit code segment that has run successfully on an 8086 processor or in real-mode on a later IA-32 architecture processor will have its D flag clear and will not use operand-size override prefixes. As a result, all CALL instructions in this code segment will use the 16-bit operand-size attribute. Procedures in these code

segments can be modified to safely call procedures to 32-bit code segments in either of two ways:

- Relink the CALL instruction to point to 32-bit call gates (see Section 21.4.2.2, “Passing Parameters With a Gate”).
- Add a 32-bit operand-size prefix to each CALL instruction.

### 21.4.2.2 Passing Parameters With a Gate

When referencing 32-bit gates with 16-bit procedures, it is important to consider the number of parameters passed in each procedure call. The count field of the gate descriptor specifies the size of the parameter string to copy from the current stack to the stack of a more privileged (numerically lower privilege level) procedure. The count field of a 16-bit gate specifies the number of 16-bit words to be copied, whereas the count field of a 32-bit gate specifies the number of 32-bit doublewords to be copied. The count field for a 32-bit gate must thus be half the size of the number of words being placed on the stack by a 16-bit procedure. Also, the 16-bit procedure must use an even number of words as parameters.

### 21.4.3 Interrupt Control Transfers

A program-control transfer caused by an exception or interrupt is always carried out through an interrupt or trap gate (located in the IDT). Here, the type of the gate (16-bit or 32-bit) determines the operand-size attribute used in the implicit call to the exception or interrupt handler procedure in another code segment.

A 32-bit interrupt or trap gate provides a safe interface to a 32-bit exception or interrupt handler when the exception or interrupt occurs in either a 32-bit or a 16-bit code segment. It is sometimes impractical, however, to place exception or interrupt handlers in 16-bit code segments, because only 16-bit return addresses are saved on the stack. If an exception or interrupt occurs in a 32-bit code segment when the EIP was greater than FFFFH, the 16-bit handler procedure cannot provide the correct return address.

### 21.4.4 Parameter Translation

When segment offsets or pointers (which contain segment offsets) are passed as parameters between 16-bit and 32-bit procedures, some translation is required. If a 32-bit procedure passes a pointer to data located beyond 64 KBytes to a 16-bit procedure, the 16-bit procedure cannot use it. Except for this limitation, interface code can perform any format conversion between 32-bit and 16-bit pointers that may be needed.

Parameters passed by value between 32-bit and 16-bit code also may require translation between 32-bit and 16-bit formats. The form of the translation is application-dependent.

## 21.4.5 Writing Interface Procedures

Placing interface code between 32-bit and 16-bit procedures can be the solution to the following interface problems:

- Allowing procedures in 16-bit code segments to call procedures with offsets greater than FFFFH in 32-bit code segments.
- Matching operand-size attributes between companion CALL and RET instructions.
- Translating parameters (data), including managing parameter strings with a variable count or an odd number of 16-bit words.
- The possible invalidation of the upper bits of the ESP register.

The interface procedure is simplified where these rules are followed.

1. The interface procedure must reside in a 32-bit code segment (the D flag for the code-segment descriptor is set).
2. All procedures that may be called by 16-bit procedures must have offsets not greater than FFFFH.
3. All return addresses saved by 16-bit procedures must have offsets not greater than FFFFH.

The interface procedure becomes more complex if any of these rules are violated. For example, if a 16-bit procedure calls a 32-bit procedure with an entry point beyond FFFFH, the interface procedure will need to provide the offset to the entry point. The mapping between 16- and 32-bit addresses is only performed automatically when a call gate is used, because the gate descriptor for a call gate contains a 32-bit address. When a call gate is not used, the interface code must provide the 32-bit address.

The structure of the interface procedure depends on the types of calls it is going to support, as follows:

- **Calls from 16-bit procedures to 32-bit procedures** — Calls to the interface procedure from a 16-bit code segment are made with 16-bit CALL instructions (by default, because the D flag for the calling code-segment descriptor is clear), and 16-bit operand-size prefixes are used with RET instructions to return from the interface procedure to the calling procedure. Calls from the interface procedure to 32-bit procedures are performed with 32-bit CALL instructions (by default, because the D flag for the interface procedure's code segment is set), and returns from the called procedures to the interface procedure are performed with 32-bit RET instructions (also by default).
- **Calls from 32-bit procedures to 16-bit procedures** — Calls to the interface procedure from a 32-bit code segment are made with 32-bit CALL instructions (by default), and returns to the calling procedure from the interface procedure are made with 32-bit RET instructions (also by default). Calls from the interface procedure to 16-bit procedures require the CALL instructions to have the operand-size prefixes, and returns from the called procedures to the interface procedure are performed with 16-bit RET instructions (by default).

# CHAPTER 22

## ARCHITECTURE COMPATIBILITY

---

Intel 64 and IA-32 processors are binary compatible. Compatibility means that, within limited constraints, programs that execute on previous generations of processors will produce identical results when executed on later processors. The compatibility constraints and any implementation differences between the Intel 64 and IA-32 processors are described in this chapter.

Each new processor has enhanced the software visible architecture from that found in earlier Intel 64 and IA-32 processors. Those enhancements have been defined with consideration for compatibility with previous and future processors. This chapter also summarizes the compatibility considerations for those extensions.

### 22.1 PROCESSOR FAMILIES AND CATEGORIES

IA-32 processors are referred to in several different ways in this chapter, depending on the type of compatibility information being related, as described in the following:

- **IA-32 Processors** — All the Intel processors based on the Intel IA-32 Architecture, which include the 8086/88, Intel 286, Intel386, Intel486, Pentium, Pentium Pro, Pentium II, Pentium III, Pentium 4, and Intel Xeon processors.
- **32-bit Processors** — All the IA-32 processors that use a 32-bit architecture, which include the Intel386, Intel486, Pentium, Pentium Pro, Pentium II, Pentium III, Pentium 4, and Intel Xeon processors.
- **16-bit Processors** — All the IA-32 processors that use a 16-bit architecture, which include the 8086/88 and Intel 286 processors.
- **P6 Family Processors** — All the IA-32 processors that are based on the P6 microarchitecture, which include the Pentium Pro, Pentium II, and Pentium III processors.
- **Pentium® 4 Processors** — A family of IA-32 and Intel 64 processors that are based on the Intel NetBurst® microarchitecture.
- **Intel® Pentium® M Processors** — A family of IA-32 processors that are based on the Intel Pentium M processor microarchitecture.
- **Intel® Core™ Duo and Solo Processors** — Families of IA-32 processors that are based on an improved Intel Pentium M processor microarchitecture.
- **Intel® Xeon® Processors** — A family of IA-32 and Intel 64 processors that are based on the Intel NetBurst microarchitecture. This family includes the Intel Xeon processor and the Intel Xeon processor MP based on the Intel NetBurst microarchitecture. Intel Xeon processors 3000, 3100, 3200, 3300, 3200, 5100, 5200, 5300, 5400, 7200, 7300 series are based on Intel Core microarchitectures and support Intel 64 architecture.



- **Pentium® D Processors** — A family of dual-core Intel 64 processors that provides two processor cores in a physical package. Each core is based on the Intel NetBurst microarchitecture.
- **Pentium® Processor Extreme Editions** — A family of dual-core Intel 64 processors that provides two processor cores in a physical package. Each core is based on the Intel NetBurst microarchitecture and supports Intel Hyper-Threading Technology.
- **Intel® Core™ 2 Processor family**— A family of Intel 64 processors that are based on the Intel Core microarchitecture. Intel Pentium Dual-Core processors are also based on the Intel Core microarchitecture.
- **Intel® Atom™ Processors** — A family of IA-32 and Intel 64 processors that are based on the Intel Atom microarchitecture.

## 22.2 RESERVED BITS

Throughout this manual, certain bits are marked as reserved in many register and memory layout descriptions. When bits are marked as undefined or reserved, it is essential for compatibility with future processors that software treat these bits as having a future, though unknown effect. Software should follow these guidelines in dealing with reserved bits:

- Do not depend on the states of any reserved bits when testing the values of registers or memory locations that contain such bits. Mask out the reserved bits before testing.
- Do not depend on the states of any reserved bits when storing them to memory or to a register.
- Do not depend on the ability to retain information written into any reserved bits.
- When loading a register, always load the reserved bits with the values indicated in the documentation, if any, or reload them with values previously read from the same register.

Software written for existing IA-32 processor that handles reserved bits correctly will port to future IA-32 processors without generating protection exceptions.

## 22.3 ENABLING NEW FUNCTIONS AND MODES

Most of the new control functions defined for the P6 family and Pentium processors are enabled by new mode flags in the control registers (primarily register CR4). This register is undefined for IA-32 processors earlier than the Pentium processor. Attempting to access this register with an Intel486 or earlier IA-32 processor results in an invalid-opcode exception (#UD). Consequently, programs that execute correctly on the Intel486 or earlier IA-32 processor cannot erroneously enable these functions. Attempting to set a reserved bit in register CR4 to a value other than its

original value results in a general-protection exception (#GP). So, programs that execute on the P6 family and Pentium processors cannot erroneously enable functions that may be implemented in future IA-32 processors.

The P6 family and Pentium processors do not check for attempts to set reserved bits in model-specific registers; however these bits may be checked on more recent processors. It is the obligation of the software writer to enforce this discipline. These reserved bits may be used in future Intel processors.

## 22.4 DETECTING THE PRESENCE OF NEW FEATURES THROUGH SOFTWARE

Software can check for the presence of new architectural features and extensions in either of two ways:

1. Test for the presence of the feature or extension. Software can test for the presence of new flags in the EFLAGS register and control registers. If these flags are reserved (meaning not present in the processor executing the test), an exception is generated. Likewise, software can attempt to execute a new instruction, which results in an invalid-opcode exception (#UD) being generated if it is not supported.
2. Execute the CPUID instruction. The CPUID instruction (added to the IA-32 in the Pentium processor) indicates the presence of new features directly.

See Chapter 14, “Processor Identification and Feature Determination,” in the *Intel® 64 and IA-32 Architectures Software Developer’s Manual, Volume 1*, for detailed information on detecting new processor features and extensions.

## 22.5 INTEL MMX TECHNOLOGY

The Pentium processor with MMX technology introduced the MMX technology and a set of MMX instructions to the IA-32. The MMX instructions are described in Chapter 9, “Programming with Intel® MMX™ Technology,” in the *Intel® 64 and IA-32 Architectures Software Developer’s Manual, Volume 1*, and in the *Intel® 64 and IA-32 Architectures Software Developer’s Manual, Volumes 2A, 2B & 2C*. The MMX technology and MMX instructions are also included in the Pentium II, Pentium III, Pentium 4, and Intel Xeon processors.

## 22.6 STREAMING SIMD EXTENSIONS (SSE)

The Streaming SIMD Extensions (SSE) were introduced in the Pentium III processor. The SSE extensions consist of a new set of instructions and a new set of registers. The new registers include the eight 128-bit XMM registers and the 32-bit MXCSR

control and status register. These instructions and registers are designed to allow SIMD computations to be made on single-precision floating-point numbers. Several of these new instructions also operate in the MMX registers. SSE instructions and registers are described in Section 10, “Programming with Streaming SIMD Extensions (SSE),” in the *Intel® 64 and IA-32 Architectures Software Developer’s Manual, Volume 1*, and in the *Intel® 64 and IA-32 Architectures Software Developer’s Manual, Volumes 2A, 2B & 2C*.

## 22.7 STREAMING SIMD EXTENSIONS 2 (SSE2)

The Streaming SIMD Extensions 2 (SSE2) were introduced in the Pentium 4 and Intel Xeon processors. They consist of a new set of instructions that operate on the XMM and MXCSR registers and perform SIMD operations on double-precision floating-point values and on integer values. Several of these new instructions also operate in the MMX registers. SSE2 instructions and registers are described in Chapter 11, “Programming with Streaming SIMD Extensions 2 (SSE2),” in the *Intel® 64 and IA-32 Architectures Software Developer’s Manual, Volume 1*, and in the *Intel® 64 and IA-32 Architectures Software Developer’s Manual, Volumes 2A, 2B & 2C*.

## 22.8 STREAMING SIMD EXTENSIONS 3 (SSE3)

The Streaming SIMD Extensions 3 (SSE3) were introduced in Pentium 4 processors supporting Intel Hyper-Threading Technology and Intel Xeon processors. SSE3 extensions include 13 instructions. Ten of these 13 instructions support the single instruction multiple data (SIMD) execution model used with SSE/SSE2 extensions. One SSE3 instruction accelerates x87 style programming for conversion to integer. The remaining two instructions (MONITOR and MWAIT) accelerate synchronization of threads. SSE3 instructions are described in Chapter 12, “Programming with SSE3, SSSE3 and SSE4,” in the *Intel® 64 and IA-32 Architectures Software Developer’s Manual, Volume 1*, and in the *Intel® 64 and IA-32 Architectures Software Developer’s Manual, Volumes 2A, 2B & 2C*.

## 22.9 ADDITIONAL STREAMING SIMD EXTENSIONS

The Supplemental Streaming SIMD Extensions 3 (SSSE3) were introduced in the Intel Core 2 processor and Intel Xeon processor 5100 series. Streaming SIMD Extensions 4 provided 54 new instructions introduced in 45nm Intel Xeon processors and Intel Core 2 processors. SSSE3, SSE4.1 and SSE4.2 instructions are described in Chapter 12, “Programming with SSE3, SSSE3 and SSE4,” in the *Intel® 64 and IA-32 Architectures Software Developer’s Manual, Volume 1*, and in the *Intel® 64 and IA-32 Architectures Software Developer’s Manual, Volumes 2A, 2B & 2C*.

## 22.10 INTEL HYPER-THREADING TECHNOLOGY

Intel Hyper-Threading Technology provides two logical processors that can execute two separate code streams (called *threads*) concurrently by using shared resources in a single processor core or in a physical package.

This feature was introduced in the Intel Xeon processor MP and later steppings of the Intel Xeon processor, and Pentium 4 processors supporting Intel Hyper-Threading Technology. The feature is also found in the Pentium processor Extreme Edition. See also: Section 8.7, “Intel® Hyper-Threading Technology Architecture.”

Intel Atom processors also support Intel Hyper-Threading Technology.

## 22.11 MULTI-CORE TECHNOLOGY

The Pentium D processor and Pentium processor Extreme Edition provide two processor cores in each physical processor package. See also: Section 8.5, “Intel® Hyper-Threading Technology and Intel® Multi-Core Technology,” and Section 8.8, “Multi-Core Architecture.” Intel Core 2 Duo, Intel Pentium Dual-Core processors, Intel Xeon processors 3000, 3100, 5100, 5200 series provide two processor cores in each physical processor package. Intel Core 2 Extreme, Intel Core 2 Quad processors, Intel Xeon processors 3200, 3300, 5300, 5400, 7300 series provide two processor cores in each physical processor package.

## 22.12 SPECIFIC FEATURES OF DUAL-CORE PROCESSOR

Dual-core processors may have some processor-specific features. Use CPUID feature flags to detect the availability features. Note the following:

- **CPUID Brand String** — On Pentium processor Extreme Edition, the process will report the correct brand string only after the correct microcode updates are loaded.
- **Enhanced Intel SpeedStep Technology** — This feature is supported in Pentium D processor but not in Pentium processor Extreme Edition.

## 22.13 NEW INSTRUCTIONS IN THE PENTIUM AND LATER IA-32 PROCESSORS

Table 22-1 identifies the instructions introduced into the IA-32 in the Pentium processor and later IA-32 processors.

### 22.13.1 Instructions Added Prior to the Pentium Processor

The following instructions were added in the Intel486 processor:

- BSWAP (byte swap) instruction.
- XADD (exchange and add) instruction.
- CMPXCHG (compare and exchange) instruction.
- INVD (invalidate cache) instruction.
- WBINVD (write-back and invalidate cache) instruction.
- INVLPG (invalidate TLB entry) instruction.

**Table 22-1. New Instruction in the Pentium Processor and Later IA-32 Processors**

Instruction	CPUID Identification Bits	Introduced In
CMOV <sub>cc</sub> (conditional move)	EDX, Bit 15	Pentium Pro processor
FCMOV <sub>cc</sub> (floating-point conditional move)	EDX, Bits 0 and 15	
FCOMI (floating-point compare and set EFLAGS)	EDX, Bits 0 and 15	
RDPMS (read performance monitoring counters)	EAX, Bits 8-11, set to 6H; see Note 1	
UD2 (undefined)	EAX, Bits 8-11, set to 6H	
CMPXCHG8B (compare and exchange 8 bytes)	EDX, Bit 8	Pentium processor
CPUID (CPU identification)	None; see Note 2	
RDTSC (read time-stamp counter)	EDX, Bit 4	
RDMSR (read model-specific register)	EDX, Bit 5	
WRMSR (write model-specific register)	EDX, Bit 5	
MMX Instructions	EDX, Bit 23	

**NOTES:**

1. The RDPMS instruction was introduced in the P6 family of processors and added to later model Pentium processors. This instruction is model specific in nature and not architectural.
2. The CPUID instruction is available in all Pentium and P6 family processors and in later models of the Intel486 processors. The ability to set and clear the ID flag (bit 21) in the EFLAGS register indicates the availability of the CPUID instruction.

The following instructions were added in the Intel386 processor:

- LSS, LFS, and LGS (load SS, FS, and GS registers).
- Long-displacement conditional jumps.

- Single-bit instructions.
- Bit scan instructions.
- Double-shift instructions.
- Byte set on condition instruction.
- Move with sign/zero extension.
- Generalized multiply instruction.
- MOV to and from control registers.
- MOV to and from test registers (now obsolete).
- MOV to and from debug registers.
- RSM (resume from SMM). This instruction was introduced in the Intel386 SL and Intel486 SL processors.

The following instructions were added in the Intel 387 math coprocessor:

- FPREM1.
- FUCOM, FUCOMP, and FUCOMPP.

## 22.14 OBSOLETE INSTRUCTIONS

The MOV to and from test registers instructions were removed from the Pentium processor and future IA-32 processors. Execution of these instructions generates an invalid-opcode exception (#UD).

## 22.15 UNDEFINED OPCODES

All new instructions defined for IA-32 processors use binary encodings that were reserved on earlier-generation processors. Attempting to execute a reserved opcode always results in an invalid-opcode (#UD) exception being generated. Consequently, programs that execute correctly on earlier-generation processors cannot erroneously execute these instructions and thereby produce unexpected results when executed on later IA-32 processors.

## 22.16 NEW FLAGS IN THE EFLAGS REGISTER

The section titled “EFLAGS Register” in Chapter 3, “Basic Execution Environment,” of the *Intel® 64 and IA-32 Architectures Software Developer’s Manual, Volume 1*, shows the configuration of flags in the EFLAGS register for the P6 family processors. No new flags have been added to this register in the P6 family processors. The flags added to this register in the Pentium and Intel486 processors are described in the following sections.

The following flags were added to the EFLAGS register in the Pentium processor:

- VIF (virtual interrupt flag), bit 19.
- VIP (virtual interrupt pending), bit 20.
- ID (identification flag), bit 21.

The AC flag (bit 18) was added to the EFLAGS register in the Intel486 processor.

### 22.16.1 Using EFLAGS Flags to Distinguish Between 32-Bit IA-32 Processors

The following bits in the EFLAGS register that can be used to differentiate between the 32-bit IA-32 processors:

- Bit 18 (the AC flag) can be used to distinguish an Intel386 processor from the P6 family, Pentium, and Intel486 processors. Since it is not implemented on the Intel386 processor, it will always be clear.
- Bit 21 (the ID flag) indicates whether an application can execute the CPUID instruction. The ability to set and clear this bit indicates that the processor is a P6 family or Pentium processor. The CPUID instruction can then be used to determine which processor.
- Bits 19 (the VIF flag) and 20 (the VIP flag) will always be zero on processors that do not support virtual mode extensions, which includes all 32-bit processors prior to the Pentium processor.

See Chapter 14, “Processor Identification and Feature Determination,” in the *Intel® 64 and IA-32 Architectures Software Developer’s Manual, Volume 1*, for more information on identifying processors.

## 22.17 STACK OPERATIONS

This section identifies the differences in stack implementation between the various IA-32 processors.

### 22.17.1 PUSH SP

The P6 family, Pentium, Intel486, Intel386, and Intel 286 processors push a different value on the stack for a PUSH SP instruction than the 8086 processor. The 32-bit processors push the value of the SP register before it is decremented as part of the push operation; the 8086 processor pushes the value of the SP register after it is decremented. If the value pushed is important, replace PUSH SP instructions with the following three instructions:

```
PUSH BP
MOV BP, SP
```

XCHG BP, [BP]

This code functions as the 8086 processor PUSH SP instruction on the P6 family, Pentium, Intel486, Intel386, and Intel 286 processors.

### 22.17.2 EFLAGS Pushed on the Stack

The setting of the stored values of bits 12 through 15 (which includes the IOPL field and the NT flag) in the EFLAGS register by the PUSHF instruction, by interrupts, and by exceptions is different with the 32-bit IA-32 processors than with the 8086 and Intel 286 processors. The differences are as follows:

- 8086 processor—bits 12 through 15 are always set.
- Intel 286 processor—bits 12 through 15 are always cleared in real-address mode.
- 32-bit processors in real-address mode—bit 15 (reserved) is always cleared, and bits 12 through 14 have the last value loaded into them.

## 22.18 X87 FPU

This section addresses the issues that must be faced when porting floating-point software designed to run on earlier IA-32 processors and math coprocessors to a Pentium 4, Intel Xeon, P6 family, or Pentium processor with integrated x87 FPU. To software, a Pentium 4, Intel Xeon, or P6 family processor looks very much like a Pentium processor. Floating-point software which runs on a Pentium or Intel486 DX processor, or on an Intel486 SX processor/Intel 487 SX math coprocessor system or an Intel386 processor/Intel 387 math coprocessor system, will run with at most minor modifications on a Pentium 4, Intel Xeon, or P6 family processor. To port code directly from an Intel 286 processor/Intel 287 math coprocessor system or an Intel 8086 processor/8087 math coprocessor system to a Pentium 4, Intel Xeon, P6 family, or Pentium processor, certain additional issues must be addressed.

In the following sections, the term “32-bit x87 FPUs” refers to the P6 family, Pentium, and Intel486 DX processors, and to the Intel 487 SX and Intel 387 math coprocessors; the term “16-bit IA-32 math coprocessors” refers to the Intel 287 and 8087 math coprocessors.

### 22.18.1 Control Register CR0 Flags

The ET, NE, and MP flags in control register CR0 control the interface between the integer unit of an IA-32 processor and either its internal x87 FPU or an external math coprocessor. The effect of these flags in the various IA-32 processors are described in the following paragraphs.

The ET (extension type) flag (bit 4 of the CR0 register) is used in the Intel386 processor to indicate whether the math coprocessor in the system is an Intel 287



math coprocessor (flag is clear) or an Intel 387 DX math coprocessor (flag is set). This bit is hardwired to 1 in the P6 family, Pentium, and Intel486 processors.

The NE (Numeric Exception) flag (bit 5 of the CR0 register) is used in the P6 family, Pentium, and Intel486 processors to determine whether unmasked floating-point exceptions are reported internally through interrupt vector 16 (flag is set) or externally through an external interrupt (flag is clear). On a hardware reset, the NE flag is initialized to 0, so software using the automatic internal error-reporting mechanism must set this flag to 1. This flag is nonexistent on the Intel386 processor.

As on the Intel 286 and Intel386 processors, the MP (monitor coprocessor) flag (bit 1 of register CR0) determines whether the WAIT/FWAIT instructions or waiting-type floating-point instructions trap when the context of the x87 FPU is different from that of the currently-executing task. If the MP and TS flag are set, then a WAIT/FWAIT instruction and waiting instructions will cause a device-not-available exception (interrupt vector 7). The MP flag is used on the Intel 286 and Intel386 processors to support the use of a WAIT/FWAIT instruction to wait on a device other than a math coprocessor. The device reports its status through the BUSY# pin. Since the P6 family, Pentium, and Intel486 processors do not have such a pin, the MP flag has no relevant use and should be set to 1 for normal operation.

### 22.18.2 x87 FPU Status Word

This section identifies differences to the x87 FPU status word for the different IA-32 processors and math coprocessors, the reason for the differences, and their impact on software.

#### 22.18.2.1 Condition Code Flags (C0 through C3)

The following information pertains to differences in the use of the condition code flags (C0 through C3) located in bits 8, 9, 10, and 14 of the x87 FPU status word.

After execution of a FINIT instruction or a hardware reset on a 32-bit x87 FPU, the condition code flags are set to 0. The same operations on a 16-bit IA-32 math coprocessor leave these flags intact (they contain their prior value). This difference in operation has no impact on software and provides a consistent state after reset.

Transcendental instruction results in the core range of the P6 family and Pentium processors may differ from the Intel486 DX processor and Intel 487 SX math coprocessor by 2 to 3 units in the last place (ulps)—(see “Transcendental Instruction Accuracy” in Chapter 8, “Programming with the x87 FPU,” of the *Intel® 64 and IA-32 Architectures Software Developer’s Manual, Volume 1*). As a result, the value saved in the C1 flag may also differ.

After an incomplete FPREM/FPREM1 instruction, the C0, C1, and C3 flags are set to 0 on the 32-bit x87 FPU. After the same operation on a 16-bit IA-32 math coprocessor, these flags are left intact.

On the 32-bit x87 FPUs, the C2 flag serves as an incomplete flag for the FTAN instruction. On the 16-bit IA-32 math coprocessors, the C2 flag is undefined for the FPTAN instruction. This difference has no impact on software, because Intel 287 or 8087 programs do not check C2 after an FPTAN instruction. The use of this flag on later processors allows fast checking of operand range.

### 22.18.2.2 Stack Fault Flag

When unmasked stack overflow or underflow occurs on a 32-bit x87 FPU, the IE flag (bit 0) and the SF flag (bit 6) of the x87 FPU status word are set to indicate a stack fault and condition code flag C1 is set or cleared to indicate overflow or underflow, respectively. When unmasked stack overflow or underflow occurs on a 16-bit IA-32 math coprocessor, only the IE flag is set. Bit 6 is reserved on these processors. The addition of the SF flag on a 32-bit x87 FPU has no impact on software. Existing exception handlers need not change, but may be upgraded to take advantage of the additional information.

### 22.18.3 x87 FPU Control Word

Only affine closure is supported for infinity control on a 32-bit x87 FPU. The infinity control flag (bit 12 of the x87 FPU control word) remains programmable on these processors, but has no effect. This change was made to conform to the IEEE Standard 754 for Binary Floating-Point Arithmetic. On a 16-bit IA-32 math coprocessor, both affine and projective closures are supported, as determined by the setting of bit 12. After a hardware reset, the default value of bit 12 is projective. Software that requires projective infinity arithmetic may give different results.

### 22.18.4 x87 FPU Tag Word

When loading the tag word of a 32-bit x87 FPU, using an FLDENV, FRSTOR, or FXRSTOR (Pentium III processor only) instruction, the processor examines the incoming tag and classifies the location only as empty or non-empty. Thus, tag values of 00, 01, and 10 are interpreted by the processor to indicate a non-empty location. The tag value of 11 is interpreted by the processor to indicate an empty location. Subsequent operations on a non-empty register always examine the value in the register, not the value in its tag. The FSTENV, FSAVE, and FXSAVE (Pentium III processor only) instructions examine the non-empty registers and put the correct values in the tags before storing the tag word.

The corresponding tag for a 16-bit IA-32 math coprocessor is checked before each register access to determine the class of operand in the register; the tag is updated after every change to a register so that the tag always reflects the most recent status of the register. Software can load a tag with a value that disagrees with the contents of a register (for example, the register contains a valid value, but the tag says special). Here, the 16-bit IA-32 math coprocessors honor the tag and do not examine the register.

Software written to run on a 16-bit IA-32 math coprocessor may not operate correctly on a 16-bit x87 FPU, if it uses the `FLDENV`, `FRSTOR`, or `FXRSTOR` instructions to change tags to values (other than to empty) that are different from actual register contents.

The encoding in the tag word for the 32-bit x87 FPUs for unsupported data formats (including pseudo-zero and unnormal) is special (10B), to comply with IEEE Standard 754. The encoding in the 16-bit IA-32 math coprocessors for pseudo-zero and unnormal is valid (00B) and the encoding for other unsupported data formats is special (10B). Code that recognizes the pseudo-zero or unnormal format as valid must therefore be changed if it is ported to a 32-bit x87 FPU.

### 22.18.5 Data Types

This section discusses the differences of data types for the various x87 FPUs and math coprocessors.

#### 22.18.5.1 NaNs

The 32-bit x87 FPUs distinguish between signaling NaNs (SNaNs) and quiet NaNs (QNaNs). These x87 FPUs only generate QNaNs and normally do not generate an exception upon encountering a QNaN. An invalid-operation exception (`#I`) is generated only upon encountering a SNaN, except for the `FCOM`, `FIST`, and `FBSTP` instructions, which also generates an invalid-operation exceptions for a QNaNs. This behavior matches IEEE Standard 754.

The 16-bit IA-32 math coprocessors only generate one kind of NaN (the equivalent of a QNaN), but the raise an invalid-operation exception upon encountering any kind of NaN.

When porting software written to run on a 16-bit IA-32 math coprocessor to a 32-bit x87 FPU, uninitialized memory locations that contain QNaNs should be changed to SNaNs to cause the x87 FPU or math coprocessor to fault when uninitialized memory locations are referenced.

#### 22.18.5.2 Pseudo-zero, Pseudo-NaN, Pseudo-infinity, and Unnormal Formats

The 32-bit x87 FPUs neither generate nor support the pseudo-zero, pseudo-NaN, pseudo-infinity, and unnormal formats. Whenever they encounter them in an arithmetic operation, they raise an invalid-operation exception. The 16-bit IA-32 math coprocessors define and support special handling for these formats. Support for these formats was dropped to conform with IEEE Standard 754 for Binary Floating-Point Arithmetic.

This change should not impact software ported from 16-bit IA-32 math coprocessors to 32-bit x87 FPUs. The 32-bit x87 FPUs do not generate these formats, and therefore will not encounter them unless software explicitly loads them in the data regis-

ters. The only affect may be in how software handles the tags in the tag word (see also: Section 22.18.4, “x87 FPU Tag Word”).

## 22.18.6 Floating-Point Exceptions

This section identifies the implementation differences in exception handling for floating-point instructions in the various x87 FPUs and math coprocessors.

### 22.18.6.1 Denormal Operand Exception (#D)

When the denormal operand exception is masked, the 32-bit x87 FPUs automatically normalize denormalized numbers when possible; whereas, the 16-bit IA-32 math coprocessors return a denormal result. A program written to run on a 16-bit IA-32 math coprocessor that uses the denormal exception solely to normalize denormalized operands is redundant when run on the 32-bit x87 FPUs. If such a program is run on 32-bit x87 FPUs, performance can be improved by masking the denormal exception. Floating-point programs run faster when the FPU performs normalization of denormalized operands.

The denormal operand exception is not raised for transcendental instructions and the FEXTRACT instruction on the 16-bit IA-32 math coprocessors. This exception is raised for these instructions on the 32-bit x87 FPUs. The exception handlers ported to these latter processors need to be changed only if the handlers gives special treatment to different opcodes.

### 22.18.6.2 Numeric Overflow Exception (#O)

On the 32-bit x87 FPUs, when the numeric overflow exception is masked and the rounding mode is set to chop (toward 0), the result is the largest positive or smallest negative number. The 16-bit IA-32 math coprocessors do not signal the overflow exception when the masked response is not  $\infty$ ; that is, they signal overflow only when the rounding control is not set to round to 0. If rounding is set to chop (toward 0), the result is positive or negative  $\infty$ . Under the most common rounding modes, this difference has no impact on existing software.

If rounding is toward 0 (chop), a program on a 32-bit x87 FPU produces, under overflow conditions, a result that is different in the least significant bit of the significand, compared to the result on a 16-bit IA-32 math coprocessor. The reason for this difference is IEEE Standard 754 compatibility.

When the overflow exception is not masked, the precision exception is flagged on the 32-bit x87 FPUs. When the result is stored in the stack, the significand is rounded according to the precision control (PC) field of the FPU control word or according to the opcode. On the 16-bit IA-32 math coprocessors, the precision exception is not flagged and the significand is not rounded. The impact on existing software is that if the result is stored on the stack, a program running on a 32-bit x87 FPU produces a different result under overflow conditions than on a 16-bit IA-32 math coprocessor.

The difference is apparent only to the exception handler. This difference is for IEEE Standard 754 compatibility.

### 22.18.6.3 Numeric Underflow Exception (#U)

When the underflow exception is masked on the 32-bit x87 FPU, the underflow exception is signaled when both the result is tiny and denormalization results in a loss of accuracy. When the underflow exception is unmasked and the instruction is supposed to store the result on the stack, the significand is rounded to the appropriate precision (according to the PC flag in the FPU control word, for those instructions controlled by PC, otherwise to extended precision), after adjusting the exponent.

When the underflow exception is masked on the 16-bit IA-32 math coprocessors and rounding is toward 0, the underflow exception flag is raised on a tiny result, regardless of loss of accuracy. When the underflow exception is not masked and the destination is the stack, the significand is not rounded, but instead is left as is.

When the underflow exception is masked, this difference has no impact on existing software. The underflow exception occurs less often when rounding is toward 0.

When the underflow exception not masked. A program running on a 32-bit x87 FPU produces a different result during underflow conditions than on a 16-bit IA-32 math coprocessor if the result is stored on the stack. The difference is only in the least significant bit of the significand and is apparent only to the exception handler.

### 22.18.6.4 Exception Precedence

There is no difference in the precedence of the denormal-operand exception on the 32-bit x87 FPU, whether it be masked or not. When the denormal-operand exception is not masked on the 16-bit IA-32 math coprocessors, it takes precedence over all other exceptions. This difference causes no impact on existing software, but some unneeded normalization of denormalized operands is prevented on the Intel486 processor and Intel 387 math coprocessor.

### 22.18.6.5 CS and EIP For FPU Exceptions

On the Intel 32-bit x87 FPU, the values from the CS and EIP registers saved for floating-point exceptions point to any prefixes that come before the floating-point instruction. On the 8087 math coprocessor, the saved CS and IP registers points to the floating-point instruction.

### 22.18.6.6 FPU Error Signals

The floating-point error signals to the P6 family, Pentium, and Intel486 processors do not pass through an interrupt controller; an INT# signal from an Intel 387, Intel 287 or 8087 math coprocessors does. If an 8086 processor uses another exception for

the 8087 interrupt, both exception vectors should call the floating-point-error exception handler. Some instructions in a floating-point-error exception handler may need to be deleted if they use the interrupt controller. The P6 family, Pentium, and Intel486 processors have signals that, with the addition of external logic, support reporting for emulation of the interrupt mechanism used in many personal computers.

On the P6 family, Pentium, and Intel486 processors, an undefined floating-point opcode will cause an invalid-opcode exception (#UD, interrupt vector 6). Undefined floating-point opcodes, like legal floating-point opcodes, cause a device not available exception (#NM, interrupt vector 7) when either the TS or EM flag in control register CR0 is set. The P6 family, Pentium, and Intel486 processors do not check for floating-point error conditions on encountering an undefined floating-point opcode.

### 22.18.6.7 Assertion of the FERR# Pin

When using the MS-DOS compatibility mode for handling floating-point exceptions, the FERR# pin must be connected to an input to an external interrupt controller. An external interrupt is then generated when the FERR# output drives the input to the interrupt controller and the interrupt controller in turn drives the INTR pin on the processor.

For the P6 family and Intel386 processors, an unmasked floating-point exception always causes the FERR# pin to be asserted upon completion of the instruction that caused the exception. For the Pentium and Intel486 processors, an unmasked floating-point exception may cause the FERR# pin to be asserted either at the end of the instruction causing the exception or immediately before execution of the next floating-point instruction. (Note that the next floating-point instruction would not be executed until the pending unmasked exception has been handled.) See Appendix D, "Guidelines for Writing x87 FPU Extension Handlers," in the *Intel® 64 and IA-32 Architectures Software Developer's Manual, Volume 1*, for a complete description of the required mechanism for handling floating-point exceptions using the MS-DOS compatibility mode.

Using FERR# and IGNNE# to handle floating-point exception is deprecated by modern operating systems; this approach also limits newer processors to operate with one logical processor active.

### 22.18.6.8 Invalid Operation Exception On Denormals

An invalid-operation exception is not generated on the 32-bit x87 FPUs upon encountering a denormal value when executing a FSQRT, FDIV, or FPREM instruction or upon conversion to BCD or to integer. The operation proceeds by first normalizing the value. On the 16-bit IA-32 math coprocessors, upon encountering this situation, the invalid-operation exception is generated. This difference has no impact on existing software. Software running on the 32-bit x87 FPUs continues to execute in cases where the 16-bit IA-32 math coprocessors trap. The reason for this change was to eliminate an exception from being raised.

### 22.18.6.9 Alignment Check Exceptions (#AC)

If alignment checking is enabled, a misaligned data operand on the P6 family, Pentium, and Intel486 processors causes an alignment check exception (#AC) when a program or procedure is running at privilege-level 3, except for the stack portion of the FSAVE/FNSAVE, FXSAVE, FRSTOR, and FXRSTOR instructions.

### 22.18.6.10 Segment Not Present Exception During FLDENV

On the Intel486 processor, when a segment not present exception (#NP) occurs in the middle of an FLDENV instruction, it can happen that part of the environment is loaded and part not. In such cases, the FPU control word is left with a value of 007FH. The P6 family and Pentium processors ensure the internal state is correct at all times by attempting to read the first and last bytes of the environment before updating the internal state.

### 22.18.6.11 Device Not Available Exception (#NM)

The device-not-available exception (#NM, interrupt 7) will occur in the P6 family, Pentium, and Intel486 processors as described in Section 2.5, "Control Registers," Table 2-1, and Chapter 6, "Interrupt 7—Device Not Available Exception (#NM)."

### 22.18.6.12 Coprocessor Segment Overrun Exception

The coprocessor segment overrun exception (interrupt 9) does not occur in the P6 family, Pentium, and Intel486 processors. In situations where the Intel 387 math coprocessor would cause an interrupt 9, the P6 family, Pentium, and Intel486 processors simply abort the instruction. To avoid undetected segment overruns, it is recommended that the floating-point save area be placed in the same page as the TSS. This placement will prevent the FPU environment from being lost if a page fault occurs during the execution of an FLDENV, FRSTOR, or FXRSTOR instruction while the operating system is performing a task switch.

### 22.18.6.13 General Protection Exception (#GP)

A general-protection exception (#GP, interrupt 13) occurs if the starting address of a floating-point operand falls outside a segment's size. An exception handler should be included to report these programming errors.

### 22.18.6.14 Floating-Point Error Exception (#MF)

In real mode and protected mode (not including virtual-8086 mode), interrupt vector 16 must point to the floating-point exception handler. In virtual 8086 mode, the virtual-8086 monitor can be programmed to accommodate a different location of the interrupt vector for floating-point exceptions.

## 22.18.7 Changes to Floating-Point Instructions

This section identifies the differences in floating-point instructions for the various Intel FPU and math coprocessor architectures, the reason for the differences, and their impact on software.

### 22.18.7.1 FDIV, FPREM, and FSQRT Instructions

The 32-bit x87 FPUs support operations on denormalized operands and, when detected, an underflow exception can occur, for compatibility with the IEEE Standard 754. The 16-bit IA-32 math coprocessors do not operate on denormalized operands or return underflow results. Instead, they generate an invalid-operation exception when they detect an underflow condition. An existing underflow exception handler will require change only if it gives different treatment to different opcodes. Also, it is possible that fewer invalid-operation exceptions will occur.

### 22.18.7.2 FSCALE Instruction

With the 32-bit x87 FPUs, the range of the scaling operand is not restricted. If  $(0 < |ST(1)| < 1)$ , the scaling factor is 0; therefore,  $ST(0)$  remains unchanged. If the rounded result is not exact or if there was a loss of accuracy (masked underflow), the precision exception is signaled. With the 16-bit IA-32 math coprocessors, the range of the scaling operand is restricted. If  $(0 < |ST(1)| < 1)$ , the result is undefined and no exception is signaled. The impact of this difference on existing software is that different results are delivered on the 32-bit and 16-bit FPUs and math coprocessors when  $(0 < |ST(1)| < 1)$ .

### 22.18.7.3 FPREM1 Instruction

The 32-bit x87 FPUs compute a partial remainder according to IEEE Standard 754. This instruction does not exist on the 16-bit IA-32 math coprocessors. The availability of the FPREM1 instruction has no impact on existing software.

### 22.18.7.4 FPREM Instruction

On the 32-bit x87 FPUs, the condition code flags C0, C3, C1 in the status word correctly reflect the three low-order bits of the quotient following execution of the FPREM instruction. On the 16-bit IA-32 math coprocessors, the quotient bits are incorrect when performing a reduction of  $(64^N + M)$  when  $(N \geq 1)$  and  $M$  is 1 or 2. This difference does not affect existing software; software that works around the bug should not be affected.

### 22.18.7.5 FUCOM, FUCOMP, and FUCOMPP Instructions

When executing the FUCOM, FUCOMP, and FUCOMPP instructions, the 32-bit x87 FPUs perform unordered compare according to IEEE Standard 754. These instruc-



tions do not exist on the 16-bit IA-32 math coprocessors. The availability of these new instructions has no impact on existing software.

### 22.18.7.6 FPTAN Instruction

On the 32-bit x87 FPUs, the range of the operand for the FPTAN instruction is much less restricted ( $|ST(0)| < 2^{63}$ ) than on earlier math coprocessors. The instruction reduces the operand internally using an internal  $\pi/4$  constant that is more accurate. The range of the operand is restricted to ( $|ST(0)| < \pi/4$ ) on the 16-bit IA-32 math coprocessors; the operand must be reduced to this range using FPREM. This change has no impact on existing software.

### 22.18.7.7 Stack Overflow

On the 32-bit x87 FPUs, if an FPU stack overflow occurs when the invalid-operation exception is masked, the FPU returns the real, integer, or BCD-integer indefinite value to the destination operand, depending on the instruction being executed. On the 16-bit IA-32 math coprocessors, the original operand remains unchanged following a stack overflow, but it is loaded into register ST(1). This difference has no impact on existing software.

### 22.18.7.8 FSIN, FCOS, and FSINCOS Instructions

On the 32-bit x87 FPUs, these instructions perform three common trigonometric functions. These instructions do not exist on the 16-bit IA-32 math coprocessors. The availability of these instructions has no impact on existing software, but using them provides a performance upgrade.

### 22.18.7.9 FPATAN Instruction

On the 32-bit x87 FPUs, the range of operands for the FPATAN instruction is unrestricted. On the 16-bit IA-32 math coprocessors, the absolute value of the operand in register ST(0) must be smaller than the absolute value of the operand in register ST(1). This difference has impact on existing software.

### 22.18.7.10 F2XM1 Instruction

The 32-bit x87 FPUs support a wider range of operands ( $-1 < ST(0) < +1$ ) for the F2XM1 instruction. The supported operand range for the 16-bit IA-32 math coprocessors is ( $0 \leq ST(0) \leq 0.5$ ). This difference has no impact on existing software.

### 22.18.7.11 FLD Instruction

On the 32-bit x87 FPUs, when using the FLD instruction to load an extended-real value, a denormal-operand exception is not generated because the instruction is not

arithmetic. The 16-bit IA-32 math coprocessors do report a denormal-operand exception in this situation. This difference does not affect existing software.

On the 32-bit x87 FPUs, loading a denormal value that is in single- or double-real format causes the value to be converted to extended-real format. Loading a denormal value on the 16-bit IA-32 math coprocessors causes the value to be converted to an unnormal. If the next instruction is FXTRACT or FXAM, the 32-bit x87 FPUs will give a different result than the 16-bit IA-32 math coprocessors. This change was made for IEEE Standard 754 compatibility.

On the 32-bit x87 FPUs, loading an SNaN that is in single- or double-real format causes the FPU to generate an invalid-operation exception. The 16-bit IA-32 math coprocessors do not raise an exception when loading a signaling NaN. The invalid-operation exception handler for 16-bit math coprocessor software needs to be updated to handle this condition when porting software to 32-bit FPUs. This change was made for IEEE Standard 754 compatibility.

#### 22.18.7.12 FXTRACT Instruction

On the 32-bit x87 FPUs, if the operand is 0 for the FXTRACT instruction, the divide-by-zero exception is reported and  $-\infty$  is delivered to register ST(1). If the operand is  $+\infty$ , no exception is reported. If the operand is 0 on the 16-bit IA-32 math coprocessors, 0 is delivered to register ST(1) and no exception is reported. If the operand is  $+\infty$ , the invalid-operation exception is reported. These differences have no impact on existing software. Software usually bypasses 0 and  $\infty$ . This change is due to the IEEE Standard 754 recommendation to fully support the “logb” function.

#### 22.18.7.13 Load Constant Instructions

On 32-bit x87 FPUs, rounding control is in effect for the load constant instructions. Rounding control is not in effect for the 16-bit IA-32 math coprocessors. Results for the FLDPI, FLDLN2, FLDLG2, and FLDL2E instructions are the same as for the 16-bit IA-32 math coprocessors when rounding control is set to round to nearest or round to  $+\infty$ . They are the same for the FLDL2T instruction when rounding control is set to round to nearest, round to  $-\infty$ , or round to zero. Results are different from the 16-bit IA-32 math coprocessors in the least significant bit of the mantissa if rounding control is set to round to  $-\infty$  or round to 0 for the FLDPI, FLDLN2, FLDLG2, and FLDL2E instructions; they are different for the FLDL2T instruction if round to  $+\infty$  is specified. These changes were implemented for compatibility with IEEE Standard 754 for Floating-Point Arithmetic recommendations.

#### 22.18.7.14 FSETPM Instruction

With the 32-bit x87 FPUs, the FSETPM instruction is treated as NOP (no operation). This instruction informs the Intel 287 math coprocessor that the processor is in protected mode. This change has no impact on existing software. The 32-bit x87

FPU's handle all addressing and exception-pointer information, whether in protected mode or not.

### 22.18.7.15 FXAM Instruction

With the 32-bit x87 FPU's, if the FPU encounters an empty register when executing the FXAM instruction, it not generate combinations of C0 through C3 equal to 1101 or 1111. The 16-bit IA-32 math coprocessors may generate these combinations, among others. This difference has no impact on existing software; it provides a performance upgrade to provide repeatable results.

### 22.18.7.16 FSAVE and FSTENV Instructions

With the 32-bit x87 FPU's, the address of a memory operand pointer stored by FSAVE or FSTENV is undefined if the previous floating-point instruction did not refer to memory

## 22.18.8 Transcendental Instructions

The floating-point results of the P6 family and Pentium processors for transcendental instructions in the core range may differ from the Intel486 processors by about 2 or 3 ulps (see "Transcendental Instruction Accuracy" in Chapter 8, "Programming with the x87 FPU," of the *Intel® 64 and IA-32 Architectures Software Developer's Manual, Volume 1*). Condition code flag C1 of the status word may differ as a result. The exact threshold for underflow and overflow will vary by a few ulps. The P6 family and Pentium processors' results will have a worst case error of less than 1 ulp when rounding to the nearest-even and less than 1.5 ulps when rounding in other modes. The transcendental instructions are guaranteed to be monotonic, with respect to the input operands, throughout the domain supported by the instruction.

Transcendental instructions may generate different results in the round-up flag (C1) on the 32-bit x87 FPU's. The round-up flag is undefined for these instructions on the 16-bit IA-32 math coprocessors. This difference has no impact on existing software.

## 22.18.9 Obsolete Instructions

The 8087 math coprocessor instructions FENI and FDISI and the Intel 287 math coprocessor instruction FSETPM are treated as integer NOP instructions in the 32-bit x87 FPU's. If these opcodes are detected in the instruction stream, no specific operation is performed and no internal states are affected.

### 22.18.10 WAIT/FWAIT Prefix Differences

On the Intel486 processor, when a WAIT/FWAIT instruction precedes a floating-point instruction (one which itself automatically synchronizes with the previous floating-point instruction), the WAIT/FWAIT instruction is treated as a no-op. Pending floating-point exceptions from a previous floating-point instruction are processed not on the WAIT/FWAIT instruction but on the floating-point instruction following the WAIT/FWAIT instruction. In such a case, the report of a floating-point exception may appear one instruction later on the Intel486 processor than on a P6 family or Pentium FPU, or on Intel 387 math coprocessor.

### 22.18.11 Operands Split Across Segments and/or Pages

On the P6 family, Pentium, and Intel486 processor FPUs, when the first half of an operand to be written is inside a page or segment and the second half is outside, a memory fault can cause the first half to be stored but not the second half. In this situation, the Intel 387 math coprocessor stores nothing.

### 22.18.12 FPU Instruction Synchronization

On the 32-bit x87 FPUs, all floating-point instructions are automatically synchronized; that is, the processor automatically waits until the previous floating-point instruction has completed before completing the next floating-point instruction. No explicit WAIT/FWAIT instructions are required to assure this synchronization. For the 8087 math coprocessors, explicit waits are required before each floating-point instruction to ensure synchronization. Although 8087 programs having explicit WAIT instructions execute perfectly on the 32-bit IA-32 processors without reassembly, these WAIT instructions are unnecessary.

## 22.19 SERIALIZING INSTRUCTIONS

Certain instructions have been defined to serialize instruction execution to ensure that modifications to flags, registers and memory are completed before the next instruction is executed (or in P6 family processor terminology “committed to machine state”). Because the P6 family processors use branch-prediction and out-of-order execution techniques to improve performance, instruction execution is not generally serialized until the results of an executed instruction are committed to machine state (see Chapter 2, “Intel® 64 and IA-32 Architectures,” in the *Intel® 64 and IA-32 Architectures Software Developer’s Manual, Volume 1*).

As a result, at places in a program or task where it is critical to have execution completed for all previous instructions before executing the next instruction (for example, at a branch, at the end of a procedure, or in multiprocessor dependent code), it is useful to add a serializing instruction. See Section 8.3, “Serializing Instructions,” for more information on serializing instructions.

## 22.20 FPU AND MATH COPROCESSOR INITIALIZATION

Table 9-1 shows the states of the FPUs in the P6 family, Pentium, Intel486 processors and of the Intel 387 math coprocessor and Intel 287 coprocessor following a power-up, reset, or INIT, or following the execution of an FINIT/FNINIT instruction. The following is some additional compatibility information concerning the initialization of x87 FPUs and math coprocessors.

### 22.20.1 Intel® 387 and Intel® 287 Math Coprocessor Initialization

Following an Intel386 processor reset, the processor identifies its coprocessor type (Intel® 287 or Intel® 387 DX math coprocessor) by sampling its ERROR# input some time after the falling edge of RESET# signal and before execution of the first floating-point instruction. The Intel 287 coprocessor keeps its ERROR# output in inactive state after hardware reset; the Intel 387 coprocessor keeps its ERROR# output in active state after hardware reset.

Upon hardware reset or execution of the FINIT/FNINIT instruction, the Intel 387 math coprocessor signals an error condition. The P6 family, Pentium, and Intel486 processors, like the Intel 287 coprocessor, do not.

### 22.20.2 Intel486 SX Processor and Intel 487 SX Math Coprocessor Initialization

When initializing an Intel486 SX processor and an Intel 487 SX math coprocessor, the initialization routine should check the presence of the math coprocessor and should set the FPU related flags (EM, MP, and NE) in control register CR0 accordingly (see Section 2.5, "Control Registers," for a complete description of these flags). Table 22-2 gives the recommended settings for these flags when the math coprocessor is present. The FSTCW instruction will give a value of FFFFH for the Intel486 SX microprocessor and 037FH for the Intel 487 SX math coprocessor.

**Table 22-2. Recommended Values of the EM, MP, and NE Flags for Intel486 SX Microprocessor/Intel 487 SX Math Coprocessor System**

CR0 Flags	Intel486 SX Processor Only	Intel 487 SX Math Coprocessor Present
EM	1	0
MP	0	1
NE	1	0, for MS-DOS* systems 1, for user-defined exception handler

The EM and MP flags in register CR0 are interpreted as shown in Table 22-3.

**Table 22-3. EM and MP Flag Interpretation**

EM	MP	Interpretation
0	0	Floating-point instructions are passed to FPU; WAIT/FWAIT and other waiting-type instructions ignore TS.
0	1	Floating-point instructions are passed to FPU; WAIT/FWAIT and other waiting-type instructions test TS.
1	0	Floating-point instructions trap to emulator; WAIT/FWAIT and other waiting-type instructions ignore TS.
1	1	Floating-point instructions trap to emulator; WAIT/FWAIT and other waiting-type instructions test TS.

Following is an example code sequence to initialize the system and check for the presence of Intel486 SX processor/Intel 487 SX math coprocessor.

```
fninit
fstcw mem_loc
mov ax, mem_loc
cmp ax, 037fh
jz Intel487_SX_Math_CoProcessor_present ;ax=037fh
jmp Intel486_SX_microprocessor_present ;ax=ffffh
```

If the Intel 487 SX math coprocessor is not present, the following code can be run to set the CR0 register for the Intel486 SX processor.

```
mov eax, cr0
and eax, ffffffffh ;make MP=0
or eax, 0024h ;make EM=1, NE=1
mov cr0, eax
```

This initialization will cause any floating-point instruction to generate a device not available exception (#NH), interrupt 7. The software emulation will then take control to execute these instructions. This code is not required if an Intel 487 SX math coprocessor is present in the system. In that case, the typical initialization routine for the Intel486 SX microprocessor will be adequate.

Also, when designing an Intel486 SX processor based system with an Intel 487 SX math coprocessor, timing loops should be independent of clock speed and clocks per instruction. One way to attain this is to implement these loops in hardware and not in software (for example, BIOS).

## 22.21 CONTROL REGISTERS

The following sections identify the new control registers and control register flags and fields that were introduced to the 32-bit IA-32 in various processor families. See Figure 2-6 for the location of these flags and fields in the control registers.

The Pentium III processor introduced one new control flag in control register CR4:

- OSXMMEXCPT (bit 10) — The OS will set this bit if it supports unmasked SIMD floating-point exceptions.

The Pentium II processor introduced one new control flag in control register CR4:

- OSFXSR (bit 9) — The OS supports saving and restoring the Pentium III processor state during context switches.

The Pentium Pro processor introduced three new control flags in control register CR4:

- PAE (bit 5) — Physical address extension. Enables paging mechanism to reference extended physical addresses when set; restricts physical addresses to 32 bits when clear (see also: Section 22.22.1.1, "Physical Memory Addressing Extension").
- PGE (bit 7) — Page global enable. Inhibits flushing of frequently-used or shared pages on CR3 writes (see also: Section 22.22.1.2, "Global Pages").
- PCE (bit 8) — Performance-monitoring counter enable. Enables execution of the RDPMC instruction at any protection level.

The content of CR4 is 0H following a hardware reset.

Control register CR4 was introduced in the Pentium processor. This register contains flags that enable certain new extensions provided in the Pentium processor:

- VME — Virtual-8086 mode extensions. Enables support for a virtual interrupt flag in virtual-8086 mode (see Section 20.3, "Interrupt and Exception Handling in Virtual-8086 Mode").
- PVI — Protected-mode virtual interrupts. Enables support for a virtual interrupt flag in protected mode (see Section 20.4, "Protected-Mode Virtual Interrupts").
- TSD — Time-stamp disable. Restricts the execution of the RDTSC instruction to procedures running at privileged level 0.
- DE — Debugging extensions. Causes an undefined opcode (#UD) exception to be generated when debug registers DR4 and DR5 are references for improved performance (see Section 22.23.3, "Debug Registers DR4 and DR5").
- PSE — Page size extensions. Enables 4-MByte pages with 32-bit paging when set (see Section 4.3, "32-Bit Paging").
- MCE — Machine-check enable. Enables the machine-check exception, allowing exception handling for certain hardware error conditions (see Chapter 15, "Machine-Check Architecture").

The Intel486 processor introduced five new flags in control register CR0:

- NE — Numeric error. Enables the normal mechanism for reporting floating-point numeric errors.
- WP — Write protect. Write-protects read-only pages against supervisor-mode accesses.
- AM — Alignment mask. Controls whether alignment checking is performed. Operates in conjunction with the AC (Alignment Check) flag.
- NW — Not write-through. Enables write-throughs and cache invalidation cycles when clear and disables invalidation cycles and write-throughs that hit in the cache when set.
- CD — Cache disable. Enables the internal cache when clear and disables the cache when set.

The Intel486 processor introduced two new flags in control register CR3:

- PCD — Page-level cache disable. The state of this flag is driven on the PCD# pin during bus cycles that are not paged, such as interrupt acknowledge cycles, when paging is enabled. The PCD# pin is used to control caching in an external cache on a cycle-by-cycle basis.
- PWT — Page-level write-through. The state of this flag is driven on the PWT# pin during bus cycles that are not paged, such as interrupt acknowledge cycles, when paging is enabled. The PWT# pin is used to control write through in an external cache on a cycle-by-cycle basis.

## 22.22 MEMORY MANAGEMENT FACILITIES

The following sections describe the new memory management facilities available in the various IA-32 processors and some compatibility differences.

### 22.22.1 New Memory Management Control Flags

The Pentium Pro processor introduced three new memory management features: physical memory addressing extension, the global bit in page-table entries, and general support for larger page sizes. These features are only available when operating in protected mode.

#### 22.22.1.1 Physical Memory Addressing Extension

The new PAE (physical address extension) flag in control register CR4, bit 5, may enable additional address lines on the processor, allowing extended physical addresses. This option can only be used when paging is enabled, using a new page-table mechanism provided to support the larger physical address range (see Section 4.1, "Paging Modes and Control Bits").



### 22.22.1.2 Global Pages

The new PGE (page global enable) flag in control register CR4, bit 7, provides a mechanism for preventing frequently used pages from being flushed from the translation lookaside buffer (TLB). When this flag is set, frequently used pages (such as pages containing kernel procedures or common data tables) can be marked global by setting the global flag in a page-directory or page-table entry.

On a task switch or a write to control register CR3 (which normally causes the TLBs to be flushed), the entries in the TLB marked global are not flushed. Marking pages global in this manner prevents unnecessary reloading of the TLB due to TLB misses on frequently used pages. See Section 4.10, "Caching Translation Information" for a detailed description of this mechanism.

### 22.22.1.3 Larger Page Sizes

The P6 family processors support large page sizes. For 32-bit paging, this facility is enabled with the PSE (page size extension) flag in control register CR4, bit 4. When this flag is set, the processor supports either 4-KByte or 4-MByte page sizes. PAE paging and IA-32e paging support 2-MByte pages regardless of the value of CR4.PSE (see Section 4.4, "PAE Paging" and Section 4.5, "IA-32e Paging"). See Chapter 4, "Paging," for more information about large page sizes.

## 22.22.2 CD and NW Cache Control Flags

The CD and NW flags in control register CR0 were introduced in the Intel486 processor. In the P6 family and Pentium processors, these flags are used to implement a writeback strategy for the data cache; in the Intel486 processor, they implement a write-through strategy. See Table 11-5 for a comparison of these bits on the P6 family, Pentium, and Intel486 processors. For complete information on caching, see Chapter 11, "Memory Cache Control."

## 22.22.3 Descriptor Types and Contents

Operating-system code that manages space in descriptor tables often contains an invalid value in the access-rights field of descriptor-table entries to identify unused entries. Access rights values of 80H and 00H remain invalid for the P6 family, Pentium, Intel486, Intel386, and Intel 286 processors. Other values that were invalid on the Intel 286 processor may be valid on the 32-bit processors because uses for these bits have been defined.

## 22.22.4 Changes in Segment Descriptor Loads

On the Intel386 processor, loading a segment descriptor always causes a locked read and write to set the accessed bit of the descriptor. On the P6 family, Pentium, and Intel486 processors, the locked read and write occur only if the bit is not already set.

## 22.23 DEBUG FACILITIES

The P6 family and Pentium processors include extensions to the Intel486 processor debugging support for breakpoints. To use the new breakpoint features, it is necessary to set the DE flag in control register CR4.

### 22.23.1 Differences in Debug Register DR6

It is not possible to write a 1 to reserved bit 12 in debug status register DR6 on the P6 family and Pentium processors; however, it is possible to write a 1 in this bit on the Intel486 processor. See Table 9-1 for the different setting of this register following a power-up or hardware reset.

### 22.23.2 Differences in Debug Register DR7

The P6 family and Pentium processors determines the type of breakpoint access by the R/W0 through R/W3 fields in debug control register DR7 as follows:

- 00 Break on instruction execution only.
- 01 Break on data writes only.
- 10 Undefined if the DE flag in control register CR4 is cleared; break on I/O reads or writes but not instruction fetches if the DE flag in control register CR4 is set.
- 11 Break on data reads or writes but not instruction fetches.

On the P6 family and Pentium processors, reserved bits 11, 12, 14 and 15 are hard-wired to 0. On the Intel486 processor, however, bit 12 can be set. See Table 9-1 for the different settings of this register following a power-up or hardware reset.

### 22.23.3 Debug Registers DR4 and DR5

Although the DR4 and DR5 registers are documented as reserved, previous generations of processors aliased references to these registers to debug registers DR6 and DR7, respectively. When debug extensions are not enabled (the DE flag in control register CR4 is cleared), the P6 family and Pentium processors remain compatible with existing software by allowing these aliased references. When debug extensions

are enabled (the DE flag is set), attempts to reference registers DR4 or DR5 will result in an invalid-opcode exception (#UD).

## 22.24 RECOGNITION OF BREAKPOINTS

For the Pentium processor, it is recommended that debuggers execute the LGDT instruction before returning to the program being debugged to ensure that breakpoints are detected. This operation does not need to be performed on the P6 family, Intel486, or Intel386 processors.

The implementation of test registers on the Intel486 processor used for testing the cache and TLB has been redesigned using MSRs on the P6 family and Pentium processors. (Note that MSRs used for this function are different on the P6 family and Pentium processors.) The MOV to and from test register instructions generate invalid-opcode exceptions (#UD) on the P6 family processors.

## 22.25 EXCEPTIONS AND/OR EXCEPTION CONDITIONS

This section describes the new exceptions and exception conditions added to the 32-bit IA-32 processors and implementation differences in existing exception handling. See Chapter 6, "Interrupt and Exception Handling," for a detailed description of the IA-32 exceptions.

The Pentium III processor introduced new state with the XMM registers. Computations involving data in these registers can produce exceptions. A new MXCSR control/status register is used to determine which exception or exceptions have occurred. When an exception associated with the XMM registers occurs, an interrupt is generated.

- SIMD floating-point exception (#XF, interrupt 19) — New exceptions associated with the SIMD floating-point registers and resulting computations.

No new exceptions were added with the Pentium Pro and Pentium II processors. The set of available exceptions is the same as for the Pentium processor. However, the following exception condition was added to the IA-32 with the Pentium Pro processor:

- Machine-check exception (#MC, interrupt 18) — New exception conditions. Many exception conditions have been added to the machine-check exception and a new architecture has been added for handling and reporting on hardware errors. See Chapter 15, "Machine-Check Architecture," for a detailed description of the new conditions.

The following exceptions and/or exception conditions were added to the IA-32 with the Pentium processor:

- Machine-check exception (#MC, interrupt 18) — New exception. This exception reports parity and other hardware errors. It is a model-specific exception and

may not be implemented or implemented differently in future processors. The MCE flag in control register CR4 enables the machine-check exception. When this bit is clear (which it is at reset), the processor inhibits generation of the machine-check exception.

- General-protection exception (#GP, interrupt 13) — New exception condition added. An attempt to write a 1 to a reserved bit position of a special register causes a general-protection exception to be generated.
- Page-fault exception (#PF, interrupt 14) — New exception condition added. When a 1 is detected in any of the reserved bit positions of a page-table entry, page-directory entry, or page-directory pointer during address translation, a page-fault exception is generated.

The following exception was added to the Intel486 processor:

- Alignment-check exception (#AC, interrupt 17) — New exception. Reports unaligned memory references when alignment checking is being performed.

The following exceptions and/or exception conditions were added to the Intel386 processor:

- Divide-error exception (#DE, interrupt 0)
  - Change in exception handling. Divide-error exceptions on the Intel386 processors always leave the saved CS:IP value pointing to the instruction that failed. On the 8086 processor, the CS:IP value points to the next instruction.
  - Change in exception handling. The Intel386 processors can generate the largest negative number as a quotient for the IDIV instruction (80H and 8000H). The 8086 processor generates a divide-error exception instead.
- Invalid-opcode exception (#UD, interrupt 6) — New exception condition added. Improper use of the LOCK instruction prefix can generate an invalid-opcode exception.
- Page-fault exception (#PF, interrupt 14) — New exception condition added. If paging is enabled in a 16-bit program, a page-fault exception can be generated as follows. Paging can be used in a system with 16-bit tasks if all tasks use the same page directory. Because there is no place in a 16-bit TSS to store the PDBR register, switching to a 16-bit task does not change the value of the PDBR register. Tasks ported from the Intel 286 processor should be given 32-bit TSSs so they can make full use of paging.
- General-protection exception (#GP, interrupt 13) — New exception condition added. The Intel386 processor sets a limit of 15 bytes on instruction length. The only way to violate this limit is by putting redundant prefixes before an instruction. A general-protection exception is generated if the limit on instruction length is violated. The 8086 processor has no instruction length limit.

### 22.25.1 Machine-Check Architecture

The Pentium Pro processor introduced a new architecture to the IA-32 for handling and reporting on machine-check exceptions. This machine-check architecture (described in detail in Chapter 15, “Machine-Check Architecture”) greatly expands the ability of the processor to report on internal hardware errors.

### 22.25.2 Priority of Exceptions

The priority of exceptions are broken down into several major categories:

1. Traps on the previous instruction
2. External interrupts
3. Faults on fetching the next instruction
4. Faults in decoding the next instruction
5. Faults on executing an instruction

There are no changes in the priority of these major categories between the different processors, however, exceptions within these categories are implementation dependent and may change from processor to processor.

### 22.25.3 Exception Conditions of Legacy SIMD Instructions Operating on MMX Registers

MMX instructions and a subset of SSE, SSE2, SSSE3 instructions operate on MMX registers. The exception conditions of these instructions are described in the following tables.

**Table 22-4. Exception Conditions for Legacy SIMD/MMX Instructions with FP Exception and 16-Byte Alignment**

Exception	Real	Virtual 8086	Protected and Compatibility	64-bit	Cause of Exception
Invalid Opcode, #UD	X	X	X	X	If an unmasked SIMD floating-point exception and CR4.OSXMMEXCPT[bit 10] = 0.
	X	X	X	X	If CR0.EM[bit 2] = 1. If CR4.OSFXSR[bit 9] = 0.
	X	X	X	X	If preceded by a LOCK prefix (FOH)
	X	X	X	X	If any corresponding CPUID feature flag is '0'
#MF	X	X	X	X	If there is a pending X87 FPU exception
#NM	X	X	X	X	If CR0.TS[bit 3]=1
Stack, SS(0)			X		For an illegal address in the SS segment
				X	If a memory address referencing the SS segment is in a non-canonical form
General Protection, #GP(0)	X	X	X	X	Legacy SSE: Memory operand is not 16-byte aligned
			X		For an illegal memory operand effective address in the CS, DS, ES, FS or GS segments.
				X	If the memory address is in a non-canonical form.
	X	X			If any part of the operand lies outside the effective address space from 0 to FFFFH
#PF(fault-code)		X	X	X	For a page fault
#XM	X	X	X	X	If an unmasked SIMD floating-point exception and CR4.OSXMMEXCPT[bit 10] = 1
Applicable Instructions	CVTPD2PI, CVTTPD2PI				

**Table 22-5. Exception Conditions for Legacy SIMD/MMX Instructions with XMM and FP Exception**

Exception	Real	Virtual 80x86	Protected and Compatibility	64-bit	Cause of Exception
Invalid Opcode, #UD	X	X	X	X	If an unmasked SIMD floating-point exception and CR4.OSXMMEXCPT[bit 10] = 0.
	X	X	X	X	If CR0.EM[bit 2] = 1. If CR4.OSFXSR[bit 9] = 0.
	X	X	X	X	If preceded by a LOCK prefix (FOH)
	X	X	X	X	If any corresponding CPUID feature flag is '0'
#MF	X	X	X	X	If there is a pending X87 FPU exception
#NM	X	X	X	X	If CR0.TS[bit 3]=1
Stack, SS(0)			X		For an illegal address in the SS segment
				X	If a memory address referencing the SS segment is in a non-canonical form
General Protection, #GP(0)			X		For an illegal memory operand effective address in the CS, DS, ES, FS or GS segments.
				X	If the memory address is in a non-canonical form.
	X	X			If any part of the operand lies outside the effective address space from 0 to FFFFH
#PF(fault-code)		X	X	X	For a page fault
Alignment Check #AC(0)		X	X	X	If alignment checking is enabled and an unaligned memory reference is made while the current privilege level is 3.
SIMD Floating-point Exception, #XM	X	X	X	X	If an unmasked SIMD floating-point exception and CR4.OSXMMEXCPT[bit 10] = 1
Applicable Instructions	CVTPI2PS, CVTPS2PI, CVTTPS2PI				

**Table 22-6. Exception Conditions for Legacy SIMD/MMX Instructions with XMM and without FP Exception**

Exception	Real	Virtual 80x86	Protected and Compatibility	64-bit	Cause of Exception
Invalid Opcode, #UD	X	X	X	X	If CRO.EM[bit 2] = 1. If CR4.OSFXSR[bit 9] = 0.
	X	X	X	X	If preceded by a LOCK prefix (F0H)
	X	X	X	X	If any corresponding CPUID feature flag is '0'
#MF <sup>1</sup>	X	X	X	X	If there is a pending X87 FPU exception
#NM	X	X	X	X	If CRO.TS[bit 3]=1
Stack, SS(0)			X		For an illegal address in the SS segment
				X	If a memory address referencing the SS segment is in a non-canonical form
General Protection, #GP(0)			X		For an illegal memory operand effective address in the CS, DS, ES, FS or GS segments.
				X	If the memory address is in a non-canonical form.
	X	X			If any part of the operand lies outside the effective address space from 0 to FFFFH
#PF(fault-code)		X	X	X	For a page fault
Alignment Check #AC(0)		X	X	X	If alignment checking is enabled and an unaligned memory reference is made while the current privilege level is 3.
Applicable Instructions	CVTPI2PD				

**NOTES:**

1. Applies to "CVTPI2PD xmm, mm" but not "CVTPI2PD xmm, m64".





**Table 22-8. Exception Conditions for Legacy SIMD/MMX Instructions without FP Exception**

Exception	Real	Virtual 80x86	Protected and Compatibility	64-bit	Cause of Exception
Invalid Opcode, #UD	X	X	X	X	If CRO.EM[bit 2] = 1. If ModR/M.mod != 11b <sup>1</sup>
	X	X	X	X	If preceded by a LOCK prefix (FOH)
	X	X	X	X	If any corresponding CPUID feature flag is '0'
#MF	X	X	X	X	If there is a pending X87 FPU exception
#NM	X	X	X	X	If CRO.TS[bit 3]=1
Stack, SS(0)			X		For an illegal address in the SS segment
				X	If a memory address referencing the SS segment is in a non-canonical form
#GP(0)			X		For an illegal memory operand effective address in the CS, DS, ES, FS or GS segments. If the destination operand is in a non-writable segment. <sup>2</sup> If the DS, ES, FS, or GS register contains a NULL segment selector. <sup>3</sup>
				X	If the memory address is in a non-canonical form.
	X	X			If any part of the operand lies outside the effective address space from 0 to FFFFH
#PF(fault-code)		X	X	X	For a page fault
#AC(0)		X	X	X	If alignment checking is enabled and an unaligned memory reference is made while the current privilege level is 3.
Applicable Instructions	MASKMOVQ, MOVNTQ, "MOVQ (mmreg)"				

**NOTES:**

- 1. Applies to MASKMOVQ only.
- 2. Applies to MASKMOVQ and MOVQ (mmreg) only.

3. Applies to MASKMOVQ only.

**Table 22-9. Exception Conditions for Legacy SIMD/MMX Instructions without Memory Reference**

Exception	Real	Virtual 80x86	Protected and Compatibility	64-bit	Cause of Exception
Invalid Opcode, #UD	X	X	X	X	If CRO.EM[bit 2] = 1.
	X	X	X	X	If preceded by a LOCK prefix (F0H)
	X	X	X	X	If any corresponding CPUID feature flag is '0'
#MF	X	X	X	X	If there is a pending X87 FPU exception
#NM			X	X	If CRO.TS[bit 3]=1
Applicable Instructions	PEXTRW, PMOVMSKB				

## 22.26 INTERRUPTS

The following differences in handling interrupts are found among the IA-32 processors.

### 22.26.1 Interrupt Propagation Delay

External hardware interrupts may be recognized on different instruction boundaries on the P6 family, Pentium, Intel486, and Intel386 processors, due to the superscaler designs of the P6 family and Pentium processors. Therefore, the EIP pushed onto the stack when servicing an interrupt may be different for the P6 family, Pentium, Intel486, and Intel386 processors.

### 22.26.2 NMI Interrupts

After an NMI interrupt is recognized by the P6 family, Pentium, Intel486, Intel386, and Intel 286 processors, the NMI interrupt is masked until the first IRET instruction is executed, unlike the 8086 processor.

### 22.26.3 IDT Limit

The LIDT instruction can be used to set a limit on the size of the IDT. A double-fault exception (#DF) is generated if an interrupt or exception attempts to read a vector beyond the limit. Shutdown then occurs on the 32-bit IA-32 processors if the double-fault handler vector is beyond the limit. (The 8086 processor does not have a shutdown mode nor a limit.)

## 22.27 ADVANCED PROGRAMMABLE INTERRUPT CONTROLLER (APIC)

The Advanced Programmable Interrupt Controller (APIC), referred to in this book as the **local APIC**, was introduced into the IA-32 processors with the Pentium processor (beginning with the 735/90 and 815/100 models) and is included in the Pentium 4, Intel Xeon, and P6 family processors. The features and functions of the local APIC are derived from the Intel 82489DX external APIC, which was used with the Intel486 and early Pentium processors. Additional refinements of the local APIC architecture were incorporated in the Pentium 4 and Intel Xeon processors.

### 22.27.1 Software Visible Differences Between the Local APIC and the 82489DX

The following features in the local APIC features differ from those found in the 82489DX external APIC:

- When the local APIC is disabled by clearing the APIC software enable/disable flag in the spurious-interrupt vector MSR, the state of its internal registers are unaffected, except that the mask bits in the LVT are all set to block local interrupts to the processor. Also, the local APIC ceases accepting IPIs except for INIT, SMI, NMI, and start-up IPIs. In the 82489DX, when the local unit is disabled, all the internal registers including the IRR, ISR and TMR are cleared and the mask bits in the LVT are set. In this state, the 82489DX local unit will accept only the reset deassert message.
- In the local APIC, NMI and INIT (except for INIT deassert) are always treated as edge triggered interrupts, even if programmed otherwise. In the 82489DX, these interrupts are always level triggered.
- In the local APIC, IPIs generated through the ICR are always treated as edge triggered (except INIT Deassert). In the 82489DX, the ICR can be used to generate either edge or level triggered IPIs.
- In the local APIC, the logical destination register supports 8 bits; in the 82489DX, it supports 32 bits.
- In the local APIC, the APIC ID register is 4 bits wide; in the 82489DX, it is 8 bits wide.

- The remote read delivery mode provided in the 82489DX and local APIC for Pentium processors is not supported in the local APIC in the Pentium 4, Intel Xeon, and P6 family processors.
- For the 82489DX, in the lowest priority delivery mode, all the target local APICs specified by the destination field participate in the lowest priority arbitration. For the local APIC, only those local APICs which have free interrupt slots will participate in the lowest priority arbitration.

### 22.27.2 New Features Incorporated in the Local APIC for the P6 Family and Pentium Processors

The local APIC in the Pentium and P6 family processors have the following new features not found in the 82489DX external APIC.

- Cluster addressing is supported in logical destination mode.
- Focus processor checking can be enabled/disabled.
- Interrupt input signal polarity can be programmed for the LINT0 and LINT1 pins.
- An SMI IPI is supported through the ICR and I/O redirection table.
- An error status register is incorporated into the LVT to log and report APIC errors.

In the P6 family processors, the local APIC incorporates an additional LVT register to handle performance monitoring counter interrupts.

### 22.27.3 New Features Incorporated in the Local APIC of the Pentium 4 and Intel Xeon Processors

The local APIC in the Pentium 4 and Intel Xeon processors has the following new features not found in the P6 family and Pentium processors and in the 82489DX.

- The local APIC ID is extended to 8 bits.
- An thermal sensor register is incorporated into the LVT to handle thermal sensor interrupts.
- The the ability to deliver lowest-priority interrupts to a focus processor is no longer supported.
- The flat cluster logical destination mode is not supported.

## 22.28 TASK SWITCHING AND TSS

This section identifies the implementation differences of task switching, additions to the TSS and the handling of TSSs and TSS segment selectors.

## 22.28.1 P6 Family and Pentium Processor TSS

When the virtual mode extensions are enabled (by setting the VME flag in control register CR4), the TSS in the P6 family and Pentium processors contain an interrupt redirection bit map, which is used in virtual-8086 mode to redirect interrupts back to an 8086 program.

## 22.28.2 TSS Selector Writes

During task state saves, the Intel486 processor writes 2-byte segment selectors into a 32-bit TSS, leaving the upper 16 bits undefined. For performance reasons, the P6 family and Pentium processors write 4-byte segment selectors into the TSS, with the upper 2 bytes being 0. For compatibility reasons, code should not depend on the value of the upper 16 bits of the selector in the TSS.

## 22.28.3 Order of Reads/Writes to the TSS

The order of reads and writes into the TSS is processor dependent. The P6 family and Pentium processors may generate different page-fault addresses in control register CR2 in the same TSS area than the Intel486 and Intel386 processors, if a TSS crosses a page boundary (which is not recommended).

## 22.28.4 Using A 16-Bit TSS with 32-Bit Constructs

Task switches using 16-bit TSSs should be used only for pure 16-bit code. Any new code written using 32-bit constructs (operands, addressing, or the upper word of the EFLAGS register) should use only 32-bit TSSs. This is due to the fact that the 32-bit processors do not save the upper 16 bits of EFLAGS to a 16-bit TSS. A task switch back to a 16-bit task that was executing in virtual mode will never re-enable the virtual mode, as this flag was not saved in the upper half of the EFLAGS value in the TSS. Therefore, it is strongly recommended that any code using 32-bit constructs use a 32-bit TSS to ensure correct behavior in a multitasking environment.

## 22.28.5 Differences in I/O Map Base Addresses

The Intel486 processor considers the TSS segment to be a 16-bit segment and wraps around the 64K boundary. Any I/O accesses check for permission to access this I/O address at the I/O base address plus the I/O offset. If the I/O map base address exceeds the specified limit of 0DFFFH, an I/O access will wrap around and obtain the permission for the I/O address at an incorrect location within the TSS. A TSS limit violation does not occur in this situation on the Intel486 processor. However, the P6 family and Pentium processors consider the TSS to be a 32-bit segment and a limit violation occurs when the I/O base address plus the I/O offset is greater than the TSS limit. By following the recommended specification for the I/O base address to be less

than 0DFFFH, the Intel486 processor will not wrap around and access incorrect locations within the TSS for I/O port validation and the P6 family and Pentium processors will not experience general-protection exceptions (#GP). Figure 22-1 demonstrates the different areas accessed by the Intel486 and the P6 family and Pentium processors.

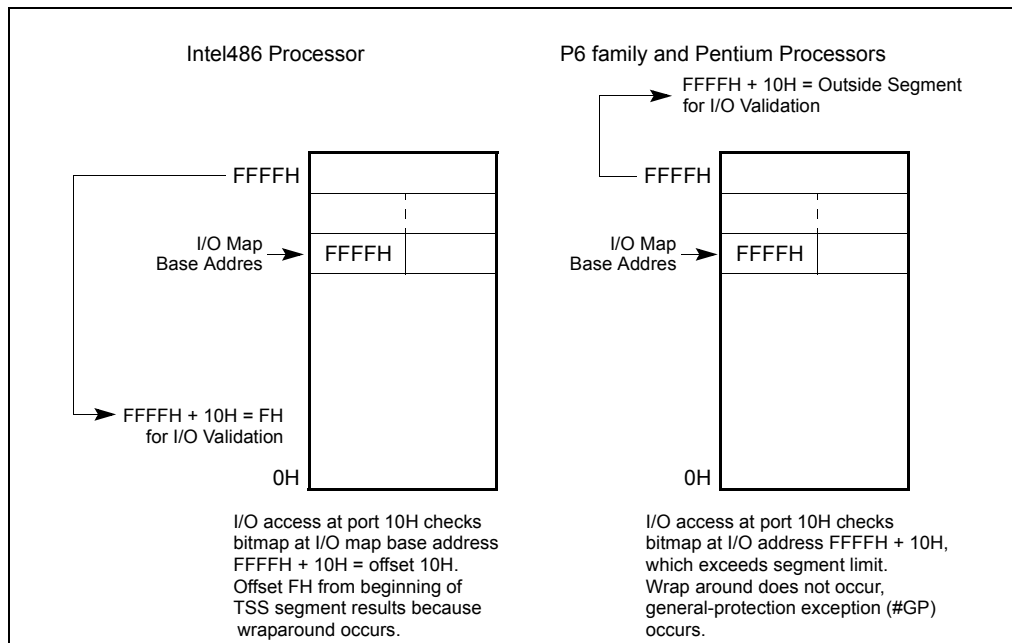


Figure 22-1. I/O Map Base Address Differences

## 22.29 CACHE MANAGEMENT

The P6 family processors include two levels of internal caches: L1 (level 1) and L2 (level 2). The L1 cache is divided into an instruction cache and a data cache; the L2 cache is a general-purpose cache. See Section 11.1, "Internal Caches, TLBs, and Buffers," for a description of these caches. (Note that although the Pentium II processor L2 cache is physically located on a separate chip in the cassette, it is considered an internal cache.)

The Pentium processor includes separate level 1 instruction and data caches. The data cache supports a writeback (or alternatively write-through, on a line by line basis) policy for memory updates.

The Intel486 processor includes a single level 1 cache for both instructions and data.

The meaning of the CD and NW flags in control register CR0 have been redefined for the P6 family and Pentium processors. For these processors, the recommended value (00B) enables writeback for the data cache of the Pentium processor and for the L1

data cache and L2 cache of the P6 family processors. In the Intel486 processor, setting these flags to (00B) enables write-through for the cache.

External system hardware can force the Pentium processor to disable caching or to use the write-through cache policy should that be required. In the P6 family processors, the MTRRs can be used to override the CD and NW flags (see Table 11-6).

The P6 family and Pentium processors support page-level cache management in the same manner as the Intel486 processor by using the PCD and PWT flags in control register CR3, the page-directory entries, and the page-table entries. The Intel486 processor, however, is not affected by the state of the PWT flag since the internal cache of the Intel486 processor is a write-through cache.

### 22.29.1 Self-Modifying Code with Cache Enabled

On the Intel486 processor, a write to an instruction in the cache will modify it in both the cache and memory. If the instruction was prefetched before the write, however, the old version of the instruction could be the one executed. To prevent this problem, it is necessary to flush the instruction prefetch unit of the Intel486 processor by coding a jump instruction immediately after any write that modifies an instruction. The P6 family and Pentium processors, however, check whether a write may modify an instruction that has been prefetched for execution. This check is based on the linear address of the instruction. If the linear address of an instruction is found to be present in the prefetch queue, the P6 family and Pentium processors flush the prefetch queue, eliminating the need to code a jump instruction after any writes that modify an instruction.

Because the linear address of the write is checked against the linear address of the instructions that have been prefetched, special care must be taken for self-modifying code to work correctly when the physical addresses of the instruction and the written data are the same, but the linear addresses differ. In such cases, it is necessary to execute a serializing operation to flush the prefetch queue after the write and before executing the modified instruction. See Section 8.3, "Serializing Instructions," for more information on serializing instructions.

#### NOTE

The check on linear addresses described above is not in practice a concern for compatibility. Applications that include self-modifying code use the same linear address for modifying and fetching the instruction. System software, such as a debugger, that might possibly modify an instruction using a different linear address than that used to fetch the instruction must execute a serializing operation, such as IRET, before the modified instruction is executed.



## 22.29.2 Disabling the L3 Cache

A unified third-level (L3) cache in processors based on Intel NetBurst microarchitecture (see Section 11.1, “Internal Caches, TLBs, and Buffers”) provides the third-level cache disable flag, bit 6 of the IA32\_MISC\_ENABLE MSR. The third-level cache disable flag allows the L3 cache to be disabled and enabled, independently of the L1 and L2 caches (see Section 11.5.4, “Disabling and Enabling the L3 Cache”). The third-level cache disable flag applies only to processors based on Intel NetBurst microarchitecture. Processors with L3 and based on other microarchitectures do not support the third-level cache disable flag.

## 22.30 PAGING

This section identifies enhancements made to the paging mechanism and implementation differences in the paging mechanism for various IA-32 processors.

### 22.30.1 Large Pages

The Pentium processor extended the memory management/paging facilities of the IA-32 to allow large (4 MBytes) pages sizes (see Section 4.3, “32-Bit Paging”). The first P6 family processor (the Pentium Pro processor) added a 2 MByte page size to the IA-32 in conjunction with the physical address extension (PAE) feature (see Section 4.4, “PAE Paging”).

The availability of large pages with 32-bit paging on any IA-32 processor can be determined via feature bit 3 (PSE) of register EDX after the CPUID instruction has been execution with an argument of 1. (Large pages are always available with PAE paging and IA-32e paging.) Intel processors that do not support the CPUID instruction support only 32-bit paging and do not support page size enhancements. (See “CPUID—CPU Identification” in Chapter 3, “Instruction Set Reference, A-L,” in the *Intel® 64 and IA-32 Architectures Software Developer’s Manual, Volume 2A*, and AP-485, *Intel Processor Identification and the CPUID Instruction*, for more information on the CPUID instruction.)

### 22.30.2 PCD and PWT Flags

The PCD and PWT flags were introduced to the IA-32 in the Intel486 processor to control the caching of pages:

- PCD (page-level cache disable) flag—Controls caching on a page-by-page basis.
- PWT (page-level write-through) flag—Controls the write-through/writeback caching policy on a page-by-page basis. Since the internal cache of the Intel486 processor is a write-through cache, it is not affected by the state of the PWT flag.

### 22.30.3 Enabling and Disabling Paging

Paging is enabled and disabled by loading a value into control register CR0 that modifies the PG flag. For backward and forward compatibility with all IA-32 processors, Intel recommends that the following operations be performed when enabling or disabling paging:

1. Execute a MOV CR0, REG instruction to either set (enable paging) or clear (disable paging) the PG flag.
2. Execute a near JMP instruction.

The sequence bounded by the MOV and JMP instructions should be identity mapped (that is, the instructions should reside on a page whose linear and physical addresses are identical).

For the P6 family processors, the MOV CR0, REG instruction is serializing, so the jump operation is not required. However, for backwards compatibility, the JMP instruction should still be included.

## 22.31 STACK OPERATIONS

This section identifies the differences in the stack mechanism for the various IA-32 processors.

### 22.31.1 Selector Pushes and Pops

When pushing a segment selector onto the stack, the Pentium 4, Intel Xeon, P6 family, and Intel486 processors decrement the ESP register by the operand size and then write 2 bytes. If the operand size is 32-bits, the upper two bytes of the write are not modified. The Pentium processor decrements the ESP register by the operand size and determines the size of the write by the operand size. If the operand size is 32-bits, the upper two bytes are written as 0s.

When popping a segment selector from the stack, the Pentium 4, Intel Xeon, P6 family, and Intel486 processors read 2 bytes and increment the ESP register by the operand size of the instruction. The Pentium processor determines the size of the read from the operand size and increments the ESP register by the operand size.

It is possible to align a 32-bit selector push or pop such that the operation generates an exception on a Pentium processor and not on an Pentium 4, Intel Xeon, P6 family, or Intel486 processor. This could occur if the third and/or fourth byte of the operation lies beyond the limit of the segment or if the third and/or fourth byte of the operation is located on a non-present or inaccessible page.

For a POP-to-memory instruction that meets the following conditions:

- The stack segment size is 16-bit.
- Any 32-bit addressing form with the SIB byte specifying ESP as the base register.

- The initial stack pointer is FFFCH (32-bit operand) or FFFEh (16-bit operand) and will wrap around to 0H as a result of the POP operation.

The result of the memory write is implementation-specific. For example, in P6 family processors, the result of the memory write is SS:0H plus any scaled index and displacement. In Pentium processors, the result of the memory write may be either a stack fault (real mode or protected mode with stack segment size of 64 KByte), or write to SS:1000H plus any scaled index and displacement (protected mode and stack segment size exceeds 64 KByte).

### 22.31.2 Error Code Pushes

The Intel486 processor implements the error code pushed on the stack as a 16-bit value. When pushed onto a 32-bit stack, the Intel486 processor only pushes 2 bytes and updates ESP by 4. The P6 family and Pentium processors' error code is a full 32 bits with the upper 16 bits set to zero. The P6 family and Pentium processors, therefore, push 4 bytes and update ESP by 4. Any code that relies on the state of the upper 16 bits may produce inconsistent results.

### 22.31.3 Fault Handling Effects on the Stack

During the handling of certain instructions, such as CALL and PUSHA, faults may occur in different sequences for the different processors. For example, during far calls, the Intel486 processor pushes the old CS and EIP before a possible branch fault is resolved. A branch fault is a fault from a branch instruction occurring from a segment limit or access rights violation. If a branch fault is taken, the Intel486 and P6 family processors will have corrupted memory below the stack pointer. However, the ESP register is backed up to make the instruction restartable. The P6 family processors issue the branch before the pushes. Therefore, if a branch fault does occur, these processors do not corrupt memory below the stack pointer. This implementation difference, however, does not constitute a compatibility problem, as only values at or above the stack pointer are considered to be valid. Other operations that encounter faults may also corrupt memory below the stack pointer and this behavior may vary on different implementations.

### 22.31.4 Interlevel RET/IRET From a 16-Bit Interrupt or Call Gate

If a call or interrupt is made from a 32-bit stack environment through a 16-bit gate, only 16 bits of the old ESP can be pushed onto the stack. On the subsequent RET/IRET, the 16-bit ESP is popped but the full 32-bit ESP is updated since control is being resumed in a 32-bit stack environment. The Intel486 processor writes the SS selector into the upper 16 bits of ESP. The P6 family and Pentium processors write zeros into the upper 16 bits.

## 22.32 MIXING 16- AND 32-BIT SEGMENTS

The features of the 16-bit Intel 286 processor are an object-code compatible subset of those of the 32-bit IA-32 processors. The D (default operation size) flag in segment descriptors indicates whether the processor treats a code or data segment as a 16-bit or 32-bit segment; the B (default stack size) flag in segment descriptors indicates whether the processor treats a stack segment as a 16-bit or 32-bit segment.

The segment descriptors used by the Intel 286 processor are supported by the 32-bit IA-32 processors if the Intel-reserved word (highest word) of the descriptor is clear. On the 32-bit IA-32 processors, this word includes the upper bits of the base address and the segment limit.

The segment descriptors for data segments, code segments, local descriptor tables (there are no descriptors for global descriptor tables), and task gates are the same for the 16- and 32-bit processors. Other 16-bit descriptors (TSS segment, call gate, interrupt gate, and trap gate) are supported by the 32-bit processors.

The 32-bit processors also have descriptors for TSS segments, call gates, interrupt gates, and trap gates that support the 32-bit architecture. Both kinds of descriptors can be used in the same system.

For those segment descriptors common to both 16- and 32-bit processors, clear bits in the reserved word cause the 32-bit processors to interpret these descriptors exactly as an Intel 286 processor does, that is:

- **Base Address** — The upper 8 bits of the 32-bit base address are clear, which limits base addresses to 24 bits.
- **Limit** — The upper 4 bits of the limit field are clear, restricting the value of the limit field to 64 KBytes.
- **Granularity bit** — The G (granularity) flag is clear, indicating the value of the 16-bit limit is interpreted in units of 1 byte.
- **Big bit** — In a data-segment descriptor, the B flag is clear in the segment descriptor used by the 32-bit processors, indicating the segment is no larger than 64 KBytes.
- **Default bit** — In a code-segment descriptor, the D flag is clear, indicating 16-bit addressing and operands are the default. In a stack-segment descriptor, the D flag is clear, indicating use of the SP register (instead of the ESP register) and a 64-KByte maximum segment limit.

For information on mixing 16- and 32-bit code in applications, see Chapter 21, "Mixing 16-Bit and 32-Bit Code."

## 22.33 SEGMENT AND ADDRESS WRAPAROUND

This section discusses differences in segment and address wraparound between the P6 family, Pentium, Intel486, Intel386, Intel 286, and 8086 processors.

### 22.33.1 Segment Wraparound

On the 8086 processor, an attempt to access a memory operand that crosses offset 65,535 or 0FFFFH or offset 0 (for example, moving a word to offset 65,535 or pushing a word when the stack pointer is set to 1) causes the offset to wrap around modulo 65,536 or 010000H. With the Intel 286 processor, any base and offset combination that addresses beyond 16 MBytes wraps around to the 1 MByte of the address space. The P6 family, Pentium, Intel486, and Intel386 processors in real-address mode generate an exception in these cases:

- A general-protection exception (#GP) if the segment is a data segment (that is, if the CS, DS, ES, FS, or GS register is being used to address the segment).
- A stack-fault exception (#SS) if the segment is a stack segment (that is, if the SS register is being used).

An exception to this behavior occurs when a stack access is data aligned, and the stack pointer is pointing to the last aligned piece of data that size at the top of the stack (ESP is FFFFFFFCH). When this data is popped, no segment limit violation occurs and the stack pointer will wrap around to 0.

The address space of the P6 family, Pentium, and Intel486 processors may wrap around at 1 MByte in real-address mode. An external A20M# pin forces wraparound if enabled. On Intel 8086 processors, it is possible to specify addresses greater than 1 MByte. For example, with a selector value FFFFH and an offset of FFFFH, the effective address would be 10FFEFH (1 MByte plus 65519 bytes). The 8086 processor, which can form addresses up to 20 bits long, truncates the uppermost bit, which “wraps” this address to FFEFH. However, the P6 family, Pentium, and Intel486 processors do not truncate this bit if A20M# is not enabled.

If a stack operation wraps around the address limit, shutdown occurs. (The 8086 processor does not have a shutdown mode or a limit.)

The behavior when executing near the limit of a 4-GByte selector (limit=0xFFFFFFFF) is different between the Pentium Pro and the Pentium 4 family of processors. On the Pentium Pro, instructions which cross the limit -- for example, a two byte instruction such as INC EAX that is encoded as 0xFF 0xC0 starting exactly at the limit faults for a segment violation (a one byte instruction at 0xFFFFFFFF does not cause an exception). Using the Pentium 4 microprocessor family, neither of these situations causes a fault.

Segment wraparound and the functionality of A20M# is used primarily by older operating systems and not used by modern operating systems. On newer Intel 64 processors, A20M# may be absent.

## 22.34 STORE BUFFERS AND MEMORY ORDERING

The Pentium 4, Intel Xeon, and P6 family processors provide a store buffer for temporary storage of writes (stores) to memory (see Section 11.10, “Store Buffer”). Writes stored in the store buffer(s) are always written to memory in program order,

with the exception of “fast string” store operations (see Section 8.2.4, “Fast-String Operation and Out-of-Order Stores”).

The Pentium processor has two store buffers, one corresponding to each of the pipelines. Writes in these buffers are always written to memory in the order they were generated by the processor core.

It should be noted that only memory writes are buffered and I/O writes are not. The Pentium 4, Intel Xeon, P6 family, Pentium, and Intel486 processors do not synchronize the completion of memory writes on the bus and instruction execution after a write. An I/O, locked, or serializing instruction needs to be executed to synchronize writes with the next instruction (see Section 8.3, “Serializing Instructions”).

The Pentium 4, Intel Xeon, and P6 family processors use processor ordering to maintain consistency in the order that data is read (loaded) and written (stored) in a program and the order the processor actually carries out the reads and writes. With this type of ordering, reads can be carried out speculatively and in any order, reads can pass buffered writes, and writes to memory are always carried out in program order. (See Section 8.2, “Memory Ordering,” for more information about processor ordering.) The Pentium III processor introduced a new instruction to serialize writes and make them globally visible. Memory ordering issues can arise between a producer and a consumer of data. The SFENCE instruction provides a performance-efficient way of ensuring ordering between routines that produce weakly-ordered results and routines that consume this data.

No re-ordering of reads occurs on the Pentium processor, except under the condition noted in Section 8.2.1, “Memory Ordering in the Intel® Pentium® and Intel486™ Processors,” and in the following paragraph describing the Intel486 processor.

Specifically, the store buffers are flushed before the IN instruction is executed. No reads (as a result of cache miss) are reordered around previously generated writes sitting in the store buffers. The implication of this is that the store buffers will be flushed or emptied before a subsequent bus cycle is run on the external bus.

On both the Intel486 and Pentium processors, under certain conditions, a memory read will go onto the external bus before the pending memory writes in the buffer even though the writes occurred earlier in the program execution. A memory read will only be reordered in front of all writes pending in the buffers if all writes pending in the buffers are cache hits and the read is a cache miss. Under these conditions, the Intel486 and Pentium processors will not read from an external memory location that needs to be updated by one of the pending writes.

During a locked bus cycle, the Intel486 processor will always access external memory, it will never look for the location in the on-chip cache. All data pending in the Intel486 processor's store buffers will be written to memory before a locked cycle is allowed to proceed to the external bus. Thus, the locked bus cycle can be used for eliminating the possibility of reordering read cycles on the Intel486 processor. The Pentium processor does check its cache on a read-modify-write access and, if the cache line has been modified, writes the contents back to memory before locking the bus. The P6 family processors write to their cache on a read-modify-write operation (if the access does not split across a cache line) and does not write back to system

memory. If the access does split across a cache line, it locks the bus and accesses system memory.

I/O reads are never reordered in front of buffered memory writes on an IA-32 processor. This ensures an update of all memory locations before reading the status from an I/O device.

### 22.35 BUS LOCKING

The Intel 286 processor performs the bus locking differently than the Intel P6 family, Pentium, Intel486, and Intel386 processors. Programs that use forms of memory locking specific to the Intel 286 processor may not run properly when run on later processors.

A locked instruction is guaranteed to lock only the area of memory defined by the destination operand, but may lock a larger memory area. For example, typical 8086 and Intel 286 configurations lock the entire physical memory space. Programmers should not depend on this.

On the Intel 286 processor, the LOCK prefix is sensitive to IOPL. If the CPL is greater than the IOPL, a general-protection exception (#GP) is generated. On the Intel386 DX, Intel486, and Pentium, and P6 family processors, no check against IOPL is performed.

The Pentium processor automatically asserts the LOCK# signal when acknowledging external interrupts. After signaling an interrupt request, an external interrupt controller may use the data bus to send the interrupt vector to the processor. After receiving the interrupt request signal, the processor asserts LOCK# to insure that no other data appears on the data bus until the interrupt vector is received. This bus locking does not occur on the P6 family processors.

### 22.36 BUS HOLD

Unlike the 8086 and Intel 286 processors, but like the Intel386 and Intel486 processors, the P6 family and Pentium processors respond to requests for control of the bus from other potential bus masters, such as DMA controllers, between transfers of parts of an unaligned operand, such as two words which form a doubleword. Unlike the Intel386 processor, the P6 family, Pentium and Intel486 processors respond to bus hold during reset initialization.

### 22.37 MODEL-SPECIFIC EXTENSIONS TO THE IA-32

Certain extensions to the IA-32 are specific to a processor or family of IA-32 processors and may not be implemented or implemented in the same way in future proces-

sors. The following sections describe these model-specific extensions. The CPUID instruction indicates the availability of some of the model-specific features.

### 22.37.1 Model-Specific Registers

The Pentium processor introduced a set of model-specific registers (MSRs) for use in controlling hardware functions and performance monitoring. To access these MSRs, two new instructions were added to the IA-32 architecture: read MSR (RDMSR) and write MSR (WRMSR). The MSRs in the Pentium processor are not guaranteed to be duplicated or provided in the next generation IA-32 processors.

The P6 family processors greatly increased the number of MSRs available to software. See Chapter 34, “Model-Specific Registers (MSRs),” for a complete list of the available MSRs. The new registers control the debug extensions, the performance counters, the machine-check exception capability, the machine-check architecture, and the MTRRs. These registers are accessible using the RDMSR and WRMSR instructions. Specific information on some of these new MSRs is provided in the following sections. As with the Pentium processor MSR, the P6 family processor MSRs are not guaranteed to be duplicated or provided in the next generation IA-32 processors.

### 22.37.2 RDMSR and WRMSR Instructions

The RDMSR (read model-specific register) and WRMSR (write model-specific register) instructions recognize a much larger number of model-specific registers in the P6 family processors. (See “RDMSR—Read from Model Specific Register” and “WRMSR—Write to Model Specific Register” in the *Intel® 64 and IA-32 Architectures Software Developer’s Manual, Volumes 2A, 2B & 2C* for more information.)

### 22.37.3 Memory Type Range Registers

Memory type range registers (MTRRs) are a new feature introduced into the IA-32 in the Pentium Pro processor. MTRRs allow the processor to optimize memory operations for different types of memory, such as RAM, ROM, frame buffer memory, and memory-mapped I/O.

MTRRs are MSRs that contain an internal map of how physical address ranges are mapped to various types of memory. The processor uses this internal memory map to determine the cacheability of various physical memory locations and the optimal method of accessing memory locations. For example, if a memory location is specified in an MTRR as write-through memory, the processor handles accesses to this location as follows. It reads data from that location in lines and caches the read data or maps all writes to that location to the bus and updates the cache to maintain cache coherency. In mapping the physical address space with MTRRs, the processor recognizes five types of memory: uncacheable (UC), uncacheable, speculatable, write-combining (WC), write-through (WT), write-protected (WP), and writeback (WB).



Earlier IA-32 processors (such as the Intel486 and Pentium processors) used the KEN# (cache enable) pin and external logic to maintain an external memory map and signal cacheable accesses to the processor. The MTRR mechanism simplifies hardware designs by eliminating the KEN# pin and the external logic required to drive it.

See Chapter 9, "Processor Management and Initialization," and Chapter 34, "Model-Specific Registers (MSRs)," for more information on the MTRRs.

### 22.37.4 Machine-Check Exception and Architecture

The Pentium processor introduced a new exception called the machine-check exception (#MC, interrupt 18). This exception is used to detect hardware-related errors, such as a parity error on a read cycle.

The P6 family processors extend the types of errors that can be detected and that generate a machine-check exception. It also provides a new machine-check architecture for recording information about a machine-check error and provides extended recovery capability.

The machine-check architecture provides several banks of reporting registers for recording machine-check errors. Each bank of registers is associated with a specific hardware unit in the processor. The primary focus of the machine checks is on bus and interconnect operations; however, checks are also made of translation lookaside buffer (TLB) and cache operations.

The machine-check architecture can correct some errors automatically and allow for reliable restart of instruction execution. It also collects sufficient information for software to use in correcting other machine errors not corrected by hardware.

See Chapter 15, "Machine-Check Architecture," for more information on the machine-check exception and the machine-check architecture.

### 22.37.5 Performance-Monitoring Counters

The P6 family and Pentium processors provide two performance-monitoring counters for use in monitoring internal hardware operations. The number of performance monitoring counters and associated programming interfaces may be implementation specific for Pentium 4 processors, Pentium M processors. Later processors may have implemented these as part of an architectural performance monitoring feature. The architectural and non-architectural performance monitoring interfaces for different processor families are described in Chapter 18, "Performance Monitoring,". Chapter 19, "Performance-Monitoring Events," lists all the events that can be counted for architectural performance monitoring events and non-architectural events. The counters are set up, started, and stopped using two MSRs and the RDMSR and WRMSR instructions. For the P6 family processors, the current count for a particular counter can be read using the new RDPMC instruction.

The performance-monitoring counters are useful for debugging programs, optimizing code, diagnosing system failures, or refining hardware designs. See Chapter 18, “Performance Monitoring,” for more information on these counters.

## 22.38 TWO WAYS TO RUN INTEL 286 PROCESSOR TASKS

When porting 16-bit programs to run on 32-bit IA-32 processors, there are two approaches to consider:

- Porting an entire 16-bit software system to a 32-bit processor, complete with the old operating system, loader, and system builder. Here, all tasks will have 16-bit TSSs. The 32-bit processor is being used as if it were a faster version of the 16-bit processor.
- Porting selected 16-bit applications to run in a 32-bit processor environment with a 32-bit operating system, loader, and system builder. Here, the TSSs used to represent 286 tasks should be changed to 32-bit TSSs. It is possible to mix 16 and 32-bit TSSs, but the benefits are small and the problems are great. All tasks in a 32-bit software system should have 32-bit TSSs. It is not necessary to change the 16-bit object modules themselves; TSSs are usually constructed by the operating system, by the loader, or by the system builder. See Chapter 21, “Mixing 16-Bit and 32-Bit Code,” for more detailed information about mixing 16-bit and 32-bit code.

Because the 32-bit processors use the contents of the reserved word of 16-bit segment descriptors, 16-bit programs that place values in this word may not run correctly on the 32-bit processors.